

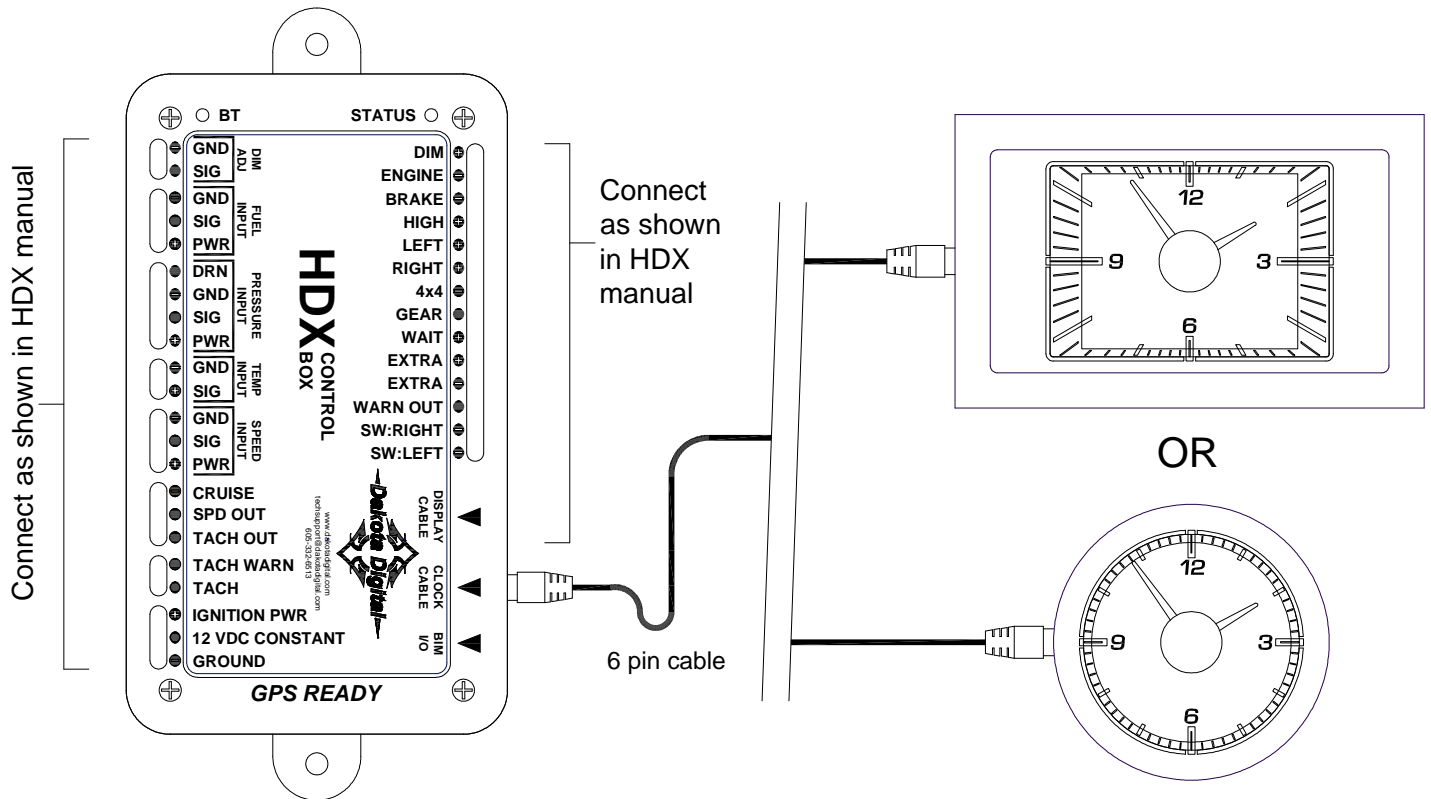

OPERATION MANUAL FOR HLC-xxx clocks Analog Clock module for use with HDX systems

CONNECTION DIAGRAM:



WIRING:

The HLC clock is NOT a stand alone unit. Connection to an HDX control box is required to operate the HLC clock.

A 6 pin cable comes with the kit to connect the HLC to the clock connector on the HDX control box. This cable provides all the needed signal and power connections for the HLC from the control box.

NOTE: Some HDX systems come with an integrated HLC unit. These systems will have the 6 pin connector located on the back of the system.

OPERATION:

CONNECTING POWER:

When power is first connected to the HLC, the hands on the clock will move quickly around the dial until they point to 12:00. This is normal and is how the HLC calibrates the location of the clock hands. After this calibration, the HLC will begin to keep time from 12:00 until the time is updated by the HDX control box.

KEY OFF/ON MODE:

When the key is turned off, the HLC will use its internal clock to keep track of time and move the hands accordingly. When the key is turned on, the HLC will update its time using time data it receives from the HDX system. If this time is different than the time on the HLC, the clock hands will move rapidly either ahead or back to adjust to this new time.

Large differences in time that cause fast hand movement can be caused by several things. If the constant power is lost on the HDX control box, its clock will be reset. Similarly if the time is provided by a BIM expansion module, constant power loss to this module will cause a clock reset. Also if the BIM expansion module that provided time became disconnected from or reconnected to the BIM connector on the HDX control box, the time may change to a different internal time.

SETTING THE CLOCK:

The HLC will automatically set itself to match the time of the HDX system. Simply connect the HLC to the HDX system with the provided 6 pin cable. When the key is turned on, it will adjust the clock hands to match the time on the HDX system.

To adjust the time on the HDX system, refer to the HDX main manual.

NOTE: The HLC may not track every change when setting but will update to match the HDX over time while the key is on.

ADJUSTING DIAL BRIGHTNESS:

The illumination for the HLC clock dial and hands is controlled by the HDX control box. The color and brightness level will match the color and brightness level of the rest of the HDX system. To adjust the color and brightness level, use the HDX control box setup menu. Different color and brightness levels can be set for day time and night time (based on the DIM line to the HDX control box.) For more details on illumination settings, see the HDX operations manual.

TROUBLESHOOTING:

Problem	Possible cause	Solution
Clock time never changes	Bad connection	Check that the clock cable is not damaged and is securely connected to HLC and control box
	No constant power on HDX box	Check for +12v with key off on constant power terminal on HDX control box
Backlights always on when key on, clock hands not keeping time	Bad connection on HLC cable	Check HLC cable connections and look for damage to cable.
Clock hands spin to 12:00 every time key turned on	HDX control box constant power terminal connected to switched power not constant	Connect HDX control box constant terminal to a circuit that has constant +12v with key off
Clock doesn't keep track of time when key is off		
Clock will not adjust time to match VHX system time	Bad connection on HLC cable	Check HLC cable connections and look for damage to cable.
Clock lighting not matching rest of system		
Backlights flash continually with the key on and time doesn't change.	HLC internal clock is damaged or not functioning properly	Call Dakota Digital for RMA number to return product for repair

HLC Specifications	
SUPPLY	
Voltage Range (BAT)	8 to 18 V
CURRENT DRAW (BAT)	
IGN off	Approximately 0.5 mA
IGN on	< 75 mA

SERVICE AND REPAIR

DAKOTA DIGITAL offers complete service and repair of its product line. In addition, technical consultation is available to help you work through any questions or problems you may be having installing one of our products. Please read through the Troubleshooting Guide. There, you will find the solution to most problems. **Should you ever need to send the unit back for repairs, please call our technical support line, (605) 332-6513, to request a Return Merchandise Authorization number.** Package the product in a good quality box along with plenty of packing material. Ship the product by UPS or insured Parcel Post. Be sure to include the RMA number on the package, and include a complete description of the problem with RMA number, your full name and address (street address preferred), and a telephone number where you can be reached during the day. Any returns for warranty work must include a copy of the dated sales receipt from your place of purchase. Send no money. We will bill you after repair.

Dakota Digital Limited Lifetime Warranty

DAKOTA DIGITAL warrants to the ORIGINAL PURCHASER of this product that should it, under normal use and condition, be proven defective in material or workmanship for the lifetime of the original vehicle it was installed in, such defect(s) will be repaired or replaced at Dakota Digital's option.

This warranty does not cover nor extend to damage to the vehicle's systems, and does not cover removal or reinstallation of the product. This Warranty does not apply to any product or part thereof which in the opinion of the Company has been damaged through alteration, improper installation, mishandling, misuse, neglect, or accident.

This Warranty is in lieu of all other expressed warranties or liabilities. Any implied warranties, including any implied warranty of merchantability, shall be limited to the duration of this written warranty. No person or representative is authorized to assume, for Dakota Digital, any liability other than expressed herein in connection with the sale of this product.



4510 W. 61st St. North

Sioux Falls, SD 57107

www.dakotadigital.com

dakotasupport@dakotadigital.com

Phone (605) 332-6513

Fax (605) 339-4106

Copyright 2016 – Dakota Digital, Inc.