



350 S. St. Charles St. Jasper, In. 47546
Ph. 812.482.2932 Fax 812.634.6632

www.ridetech.com

Part # 12090201
64-66 Mustang Coil-Over System

Front Components:

- 1 12093509 HQ Series Front Coil-Overs
- 1 12099599 Front Tru-Turn Suspension Package
- 1 12099100 Front MuscleBar

Rear Components:

- 1 12096509 HQ Series Rear Coil-Overs
- 1 12087199 Bolt-on 4 Link

Components:

- 1 85000000 Spanner Wrench



350 S. St. Charles St. Jasper, In. 47546

Ph. 812.482.2932 Fax 812.634.6632

www.ridetech.com

Part # 12093510
64-67 Mustang Front HQ Series Coil-Overs
For Use w/ Strong Arms

Shock Assembly:

2	24039999	3.6" Stroke HQ Series shock
2	90001994	.625" I.D. bearing
4	90001995	Bearing snap ring
2	90009988	Short Delrin stud top – 2"

Components:

2	59080650	Coil spring – 8" long / 650 # rate
2	90002312	2" stud top base
2	90002222	Spring retainer kit includes upper and lower spring retainer
2	90001902	Aluminum cap for Delrin ball
2	90001903	Delrin ball upper half
2	90001904	Delrin ball lower half
2	90002356	Upper Shockwave mount
2	90000563	Aluminum Upper plate

Hardware:

2	99562003	9/16" SAE Nylok jam nut	Stud top hardware
6	99311012	5/16" x 1" USS Flange bolts	Upper mount to strut tower

COILOver

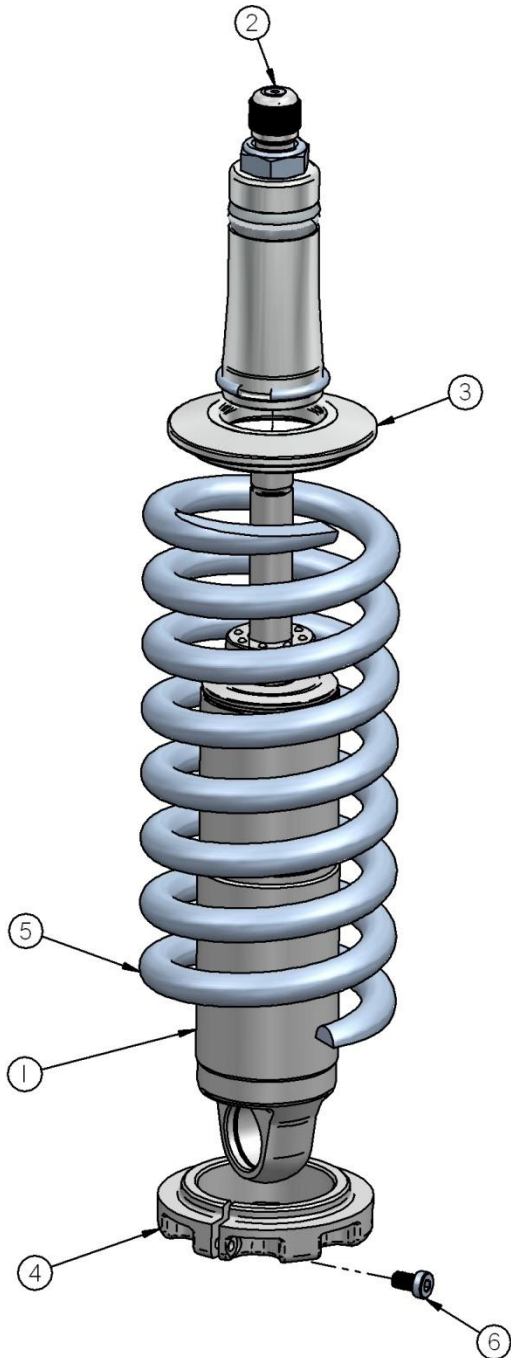

1. Impact Forged, Monotube shock
2. Rebound adjustment knob (SA Only)
3. Upper coil spring retainer
4. Lower coil spring retainer
5. High tensile coil spring
6. Set screw

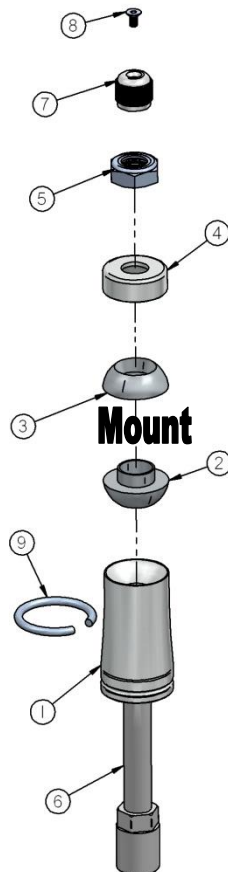

1. Stud top base
2. Lower Delrin ball half
3. Upper Delrin ball half
4. Aluminum cap
5. 9/16" Nylok jam nut
6. Threaded stud
7. Adjustment knob (SA Only)
8. Screw
9. Snap ring

COILOver

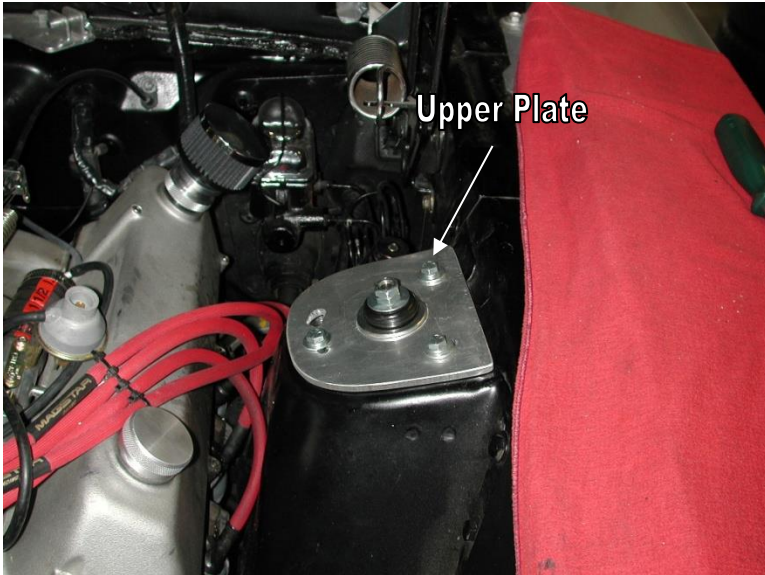

1. Place the upper plate on top of the strut tower. While holding the upper Shockwave mount up to the bottom of the strut tower, fasten the assembly with three 5/16" x 1" flange bolts.



2. Place the stud up through the upper mount. (See diagram)

3. Attach the bottom of the shock to the upper arm w/ the hardware supplied w/ the kit.



Ride Height

We have designed most cars to have a ride height of about 2" lower than factory. To achieve the best ride quality & handling, the shock absorber needs to be at 40-60% overall travel when the car is at ride height. This will ensure that the shock will not bottom out or top out over even the largest bumps. Measuring the shock can be difficult, especially on some front suspensions. Measuring overall wheel travel is just as effective and can be much easier. Most cars will have 4-6" of overall wheel travel. One easy way to determine where you are at in wheel travel is to take a measurement from the fender lip (center of the wheel) to the ground. Then lift the car by the frame until the wheel is just touching the ground, re-measure. This will indicate how far you are from full extension of the shock. A minimum of 1.5" of extension travel (at the wheel) is needed to ensure that the shock does not top out. If you are more than 3" from full extension of the shock then you are in danger of bottoming out the shock absorber.

Adjusting Spring Height

When assembling the CoilOver, screw the spring retainer tight up to the spring (0 preload). After entire weight of car is on the wheels, jounce the suspension and roll the car forward and backward to alleviate suspension bind.

- If the car is too high w/ 0 preload then a smaller rate spring is required. Although threading the spring retainer down would lower the car, this could allow the spring to fall out of its seat when lifting the car by the frame.
- If the car is too low w/ 0 preload, then preload can then be added by threading the spring retainer up to achieve ride height. On 2.6" - 4" stroke shocks, up to 1.5" of preload is acceptable. On 5-7" stroke shocks, up to 2.5" of preload is acceptable. If more preload is needed to achieve ride height a stiffer spring rate is required. Too much preload may lead to coil bind, causing ride quality to suffer.

COILOver

ridetech



350 S. St. Charles St. Jasper, In. 47546
Ph. 812.482.2932 Fax 812.634.6632

www.ridetech.com



Part # 12099599 64-66 Mustang Tru-Turn Suspension Package

Front Components:

1	12093699	Upper Strong Arms
1	12092899	Lower Strong Arms
1	12099500	Tru Turn System

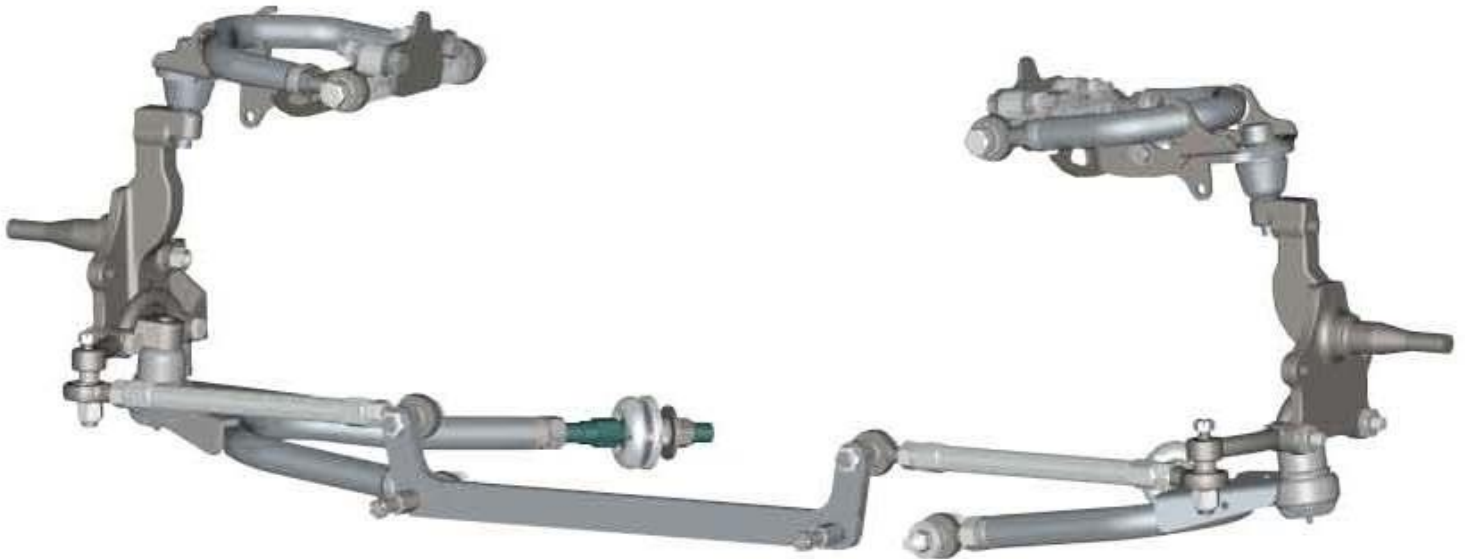



350 S. St. Charles St. Jasper, In. 47546
Ph. 812.482.2932 Fax 812.634.6632

Part # 12093699
64-66 Mustang Upper StrongArms
For Use w/ Shockwaves or CoilOvers
Must be Used with Ridetech Tru-Turn Setup

Components:

1	90002340	Driver Upper StrongArm
1	90002339	Pass Upper StrongArm
2	70010866	Upper ball joint
2	90002633	Ball joint spacer
2	90009967	Billet Aluminum drop cross shaft
4	90001589	Heim ends – 3/4"-16 thread x 5/8" I.D.
2	90002341	Alignment shim
4	90002043	.500" I.D. Bearing spacer

Hardware:

6	99311002	5/16"-18 x 1 1/4" Hex Bolt	Upper Ball joint
6	99312003	5/16"-18 Nylok Nut	Upper Ball joint
12	99313002	5/16" SAE Flat washer	Upper Ball joint
4	99621002	5/8"-18 x 1 3/4" Gr.8 bolt	Rod end to cross shaft
6	99501003	1/2"-13 x 2 1/2" Gr.5 bolt	Cross shaft to body/Shock to upper arm
4	99502006	1/2"-13 nut	Cross shaft to body
8	99503001	1/2" SAE flat washer	Cross shaft to body
4	99503002	1/2" lock washer	Cross shaft to body
2	99502001	1/2"-13 Nylok nut	Shockwave/CoilOver to upper arm
4	99752004	3/4"-16 jam nut	Heim ends

STRONG ARMS™

by Air Ride Technologies

Item #	Description	Qty.
1.	Control arm	1
2.	Heim ends – $\frac{3}{4}$ "-16 thread x $\frac{5}{8}$ " I.D.	2
3.	Alignment shim	1
4.	$\frac{5}{8}$ "-18 x $1 \frac{3}{4}$ " Gr.8 bolt	2
5.	$\frac{5}{8}$ " lock washer	2
6.	$\frac{1}{2}$ " SAE flat washer	4
7.	$\frac{5}{8}$ " SAE flat washer	2
8.	$\frac{1}{2}$ "-13 x $2 \frac{1}{2}$ " Gr.5 bolt	2
10.	Cross shaft	1
13.	$\frac{1}{2}$ "-13 Nut	2
14.	$\frac{1}{2}$ "-13 Nylok Nut	2
15.	$\frac{1}{2}$ "-13 x $2 \frac{1}{2}$ " Gr.5 bolt	1
18.	Ball Joint Spacer	2
19.	$\frac{5}{16}$ " flat washer	6
20.	$\frac{5}{16}$ "-18 x $1 \frac{1}{4}$ " bolt	3
21.	$\frac{5}{16}$ "-18 Nylok Nut	3

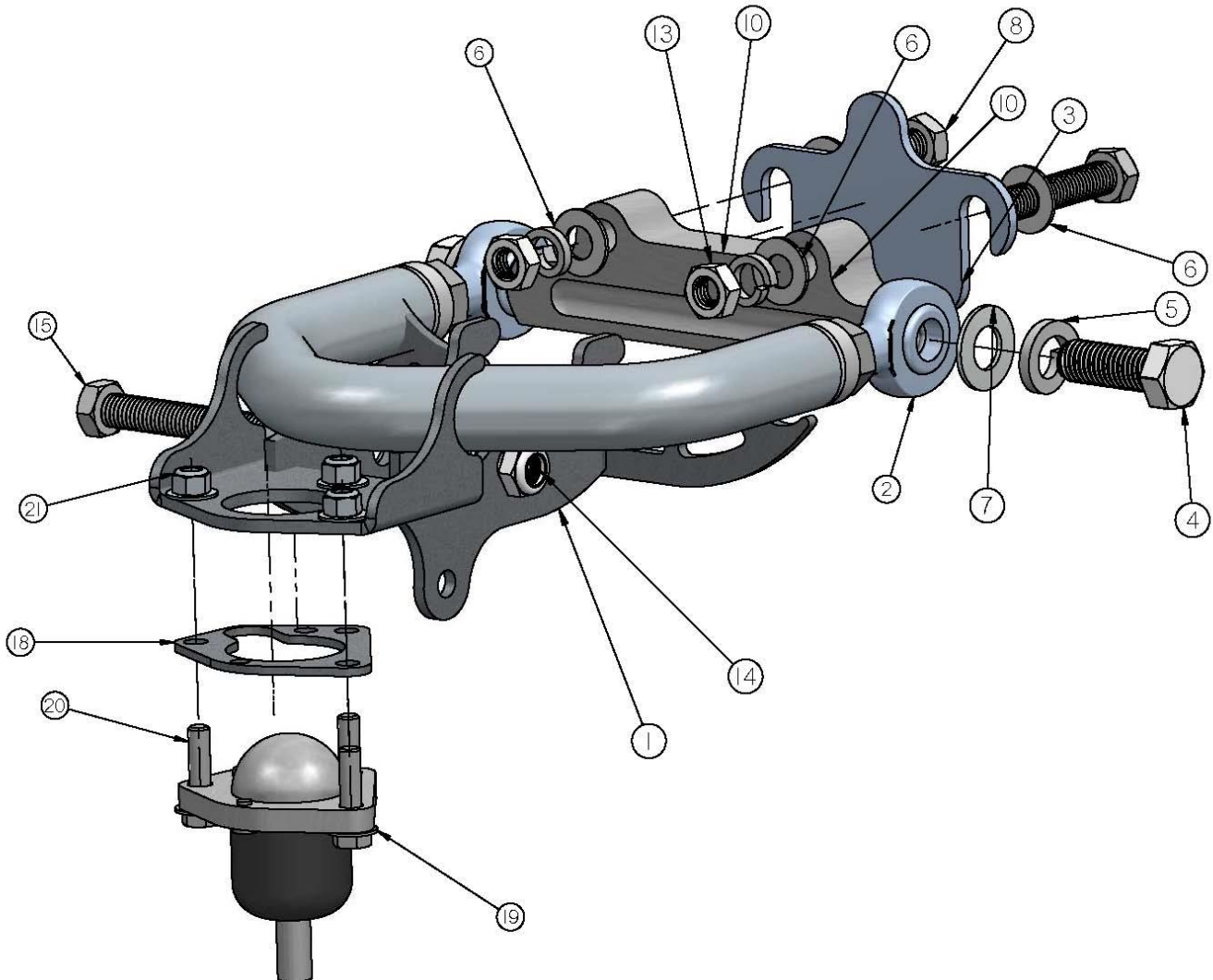

STRONG ARMS™

by Air Ride Technologies

1. Bolt the Ball Joint to the Control Arm with the BALL JOINT SPACER between the Ball Joint and Control Arm. The Ball Joints/Spacers are attached using (3) 5/16"-18 x 1 1/4" Bolts, (3) 5/16"-18 Nylok Nuts and (6) 5/16" SAE Flat Washers. Do this for both Control Arms. Refer to the Diagram on Page 3.



2. Bolt the upper StrongArm to the body using 1/2" x 2 1/2" bolts, flat washers and lock washers. The **ARROW** points to the front of the vehicle. A shim is supplied and may need to be installed between the body and the arms to achieve proper alignment.

3. The arms are preset at the factory so the alignment should be close, but the vehicle must be aligned before driving.

Note: The upper arm mounting holes on many cars have been redrilled 1" lower. This is done to improve the handling. Our cross shaft has the drop built into it; **make sure to use the factory mounting holes.**



4. Bolt the upper arm to the spindle using the hardware and cotter pin supplied.

5. Attach the Shockwave to the upper StrongArm using a 1/2" x 2 1/2" bolt and Nylok nut.

6. This control arm is designed to work with our MuscleBar sway bar. The end link will attach to the **front** mounting tab on the upper arm.



350 S. St. Charles St. Jasper, In. 47546
Ph. 812.482.2932 Fax 812.634.6632
www.ridetech.com

Part # 12092899
64-66 Mustang Lower StrongArms
To Be Used With Ridetech TRU-TURN

Components:

1	90002334	Driver side lower arm
1	90002335	Passengers side lower arm
2	90000898	Lower ball joint
2	90001589	Kevlar lined heim end
4	90002338	Rod End Spacers
2	90001045	Control arm pivot bearing
2	90002336	Bearing housing
2	90002337	Bearing retaining plate
2	90000733	Aluminum bearing spacer
2	90000732	Bearing stud (Set to 2- 7/8")

Hardware:

2	99501024	1/2"-13 x 3 1/4" Gr.5 bolt	Lower arm to frame
2	99502001	1/2"-13 Nylok nut	Lower arm to frame
6	99311003	5/16"-18 x 1 1/2 Hex	Bearing housing
6	99313003	5/16" lock washer	Bearing housing
4	99752004	3/4"-16 Jam nut	Stud to arm
2	99752001	3/4"-16 Lock nut	Stud to bearing
2	99753002	3/4" x 2" flat washer	Stud to bearing

Installation Instructions

1. Raise and support vehicle at a safe, comfortable working height. Let the front suspension hang freely.
2. Remove the coil spring, shock absorber, upper shock bracket, strut rod, sway bar, upper and lower control arms. Refer to factory service manual for proper disassembly procedure.



3. Be sure to remove the outer bushing sleeve from the strut rod frame mount.

4. Remove any excess undercoating or rust.



5. Using the bushing retainer as a template, mark the holes to drill with a center punch.

6. Remove the retainer and drill the holes with a 3/8" bit.

7. Place the bearing inside the bearing housing, then clamp it to the frame with the bearing retainer and the 5/16" x 1 1/2" SHCS and lock washers.

Front →

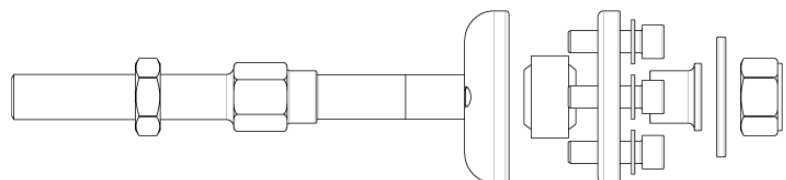



8. The bearing stud should already be threaded into the lower arm, factory set at 2-7/8" (measuring from the end of the arm to the bearing).

9. Slide the stud through the bearing, then slide the aluminum spacer over the stud with the larger end toward the front of the car. Secure the assembly with a 3/4" Nylok Nut and flat washer.

Note: The caster setting should be set at around 4.0 degrees positive. Vehicle must be aligned before driving.



10. Install the 2 aluminum spacers into the rod end that goes into the factory control arm pivot.

11. Attach the other end of the lower control arm to the factory frame mount using a 1/2" x 3 1/4" bolt and Hex nut.

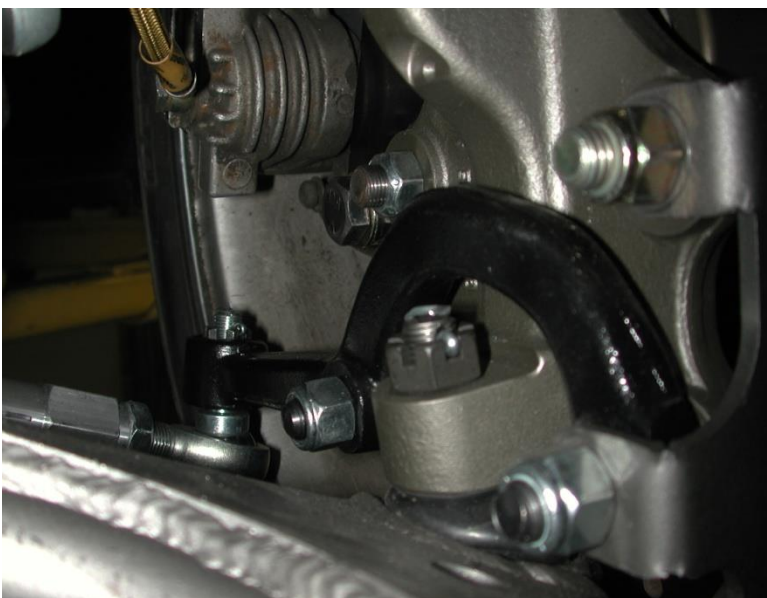

12. Slide the ball joint boot over the ball joint, then place the spindle over the ball joint stud. A ball joint spacer will be necessary to align the castle nut with the cotter pin hole. Grease ball joint

Note: Before installing the spindle, turn the ball joint stud so that the cotter pin hole faces front to back. This will make it easier to install/remove the cotter pin.

STRONG ARMS™

by Air Ride Technologies

Item #	Description	Qty.
1.	Driver side arm	1
2.	Kevlar lined Heim End	1
3.	Control Arm pivot bearing	1
4.	Bearing retaining plate	1
5.	Bearing stud (Set to 2- 7/8")	1
6.	Ball Joint	1
7.	Heim end spacer	2
8.	Bearing Housing	1
9.	5/16" Lock washer	3
10.	5/16"-1 1/2" Gr5 bolt	3
11.	Aluminum bearing spacer	1
12.	3/4"-16 Lock nut	1
13.	1/2"-13 x 3 1/4' Gr.5 bolt	1
14.	1/2"-13 Nylok nut	1
15.	3/4" -16 Jam Nut	1
16.	3/4" X 2" Flat washer	1

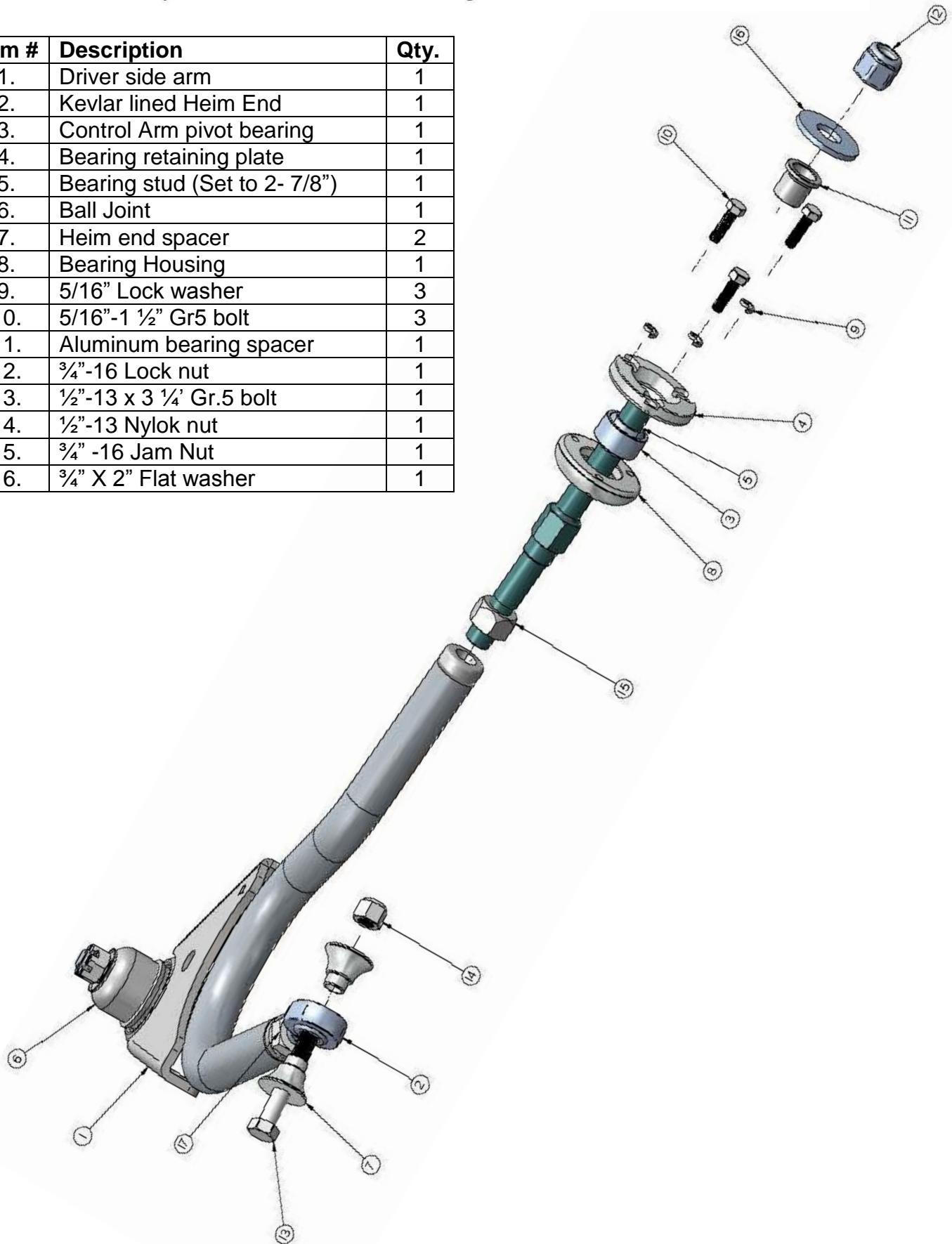

ridetech

350 S. St. Charles St. Jasper, In. 47546
 Ph. 812.482.2932 Fax 812.634.6632
www.ridetech.com

Part # 12099500 64 – 66 Mustang TruTurn System



Item #	Part #	Description-Torque Specification	Qty.
1.	90002344	Drag link bracket	1
2.	90001582	LH Thread Heim End	2
3.	99800003	5/8"-18 LH jam nut	2
4.	99800002	5/8"-18 RH jam nut	2
5.	90001590	Heim end	2
6.	90009931	Large stud – tie rod	2
7.	90002351	Inner tie rod stud	2
8.	90002345	Drag link stud	2
9.	90002346	Tie rod adjuster	2
10.	90002347	Driver steering arm	1
10.	90002348	Pass steering arm	1
11.	11009300	RideTech spindle	1 pr.
12.	99502010	1/2"-20 Lock nut-50 ft lbs	2
13.	99432005	7/16"-20 castle nut-35 ft lbs	4
14.	99952002	3/32" Cotter pin	4
15.	99622005	5/8"-18 Thin top lock nut	2
16.	90002349	Driver steering stop	1
16.	90002350	Pass steering stop	1
17.	99502001	1/2"-13 Nylok Nut	2
18.	99501019	1/2"-13 x 1 1/4" Hex Head Bolt	2
19.	99622007	5/8"-18 Mechanical lock nut	4
	99433002	7/16" Flatwasher	6

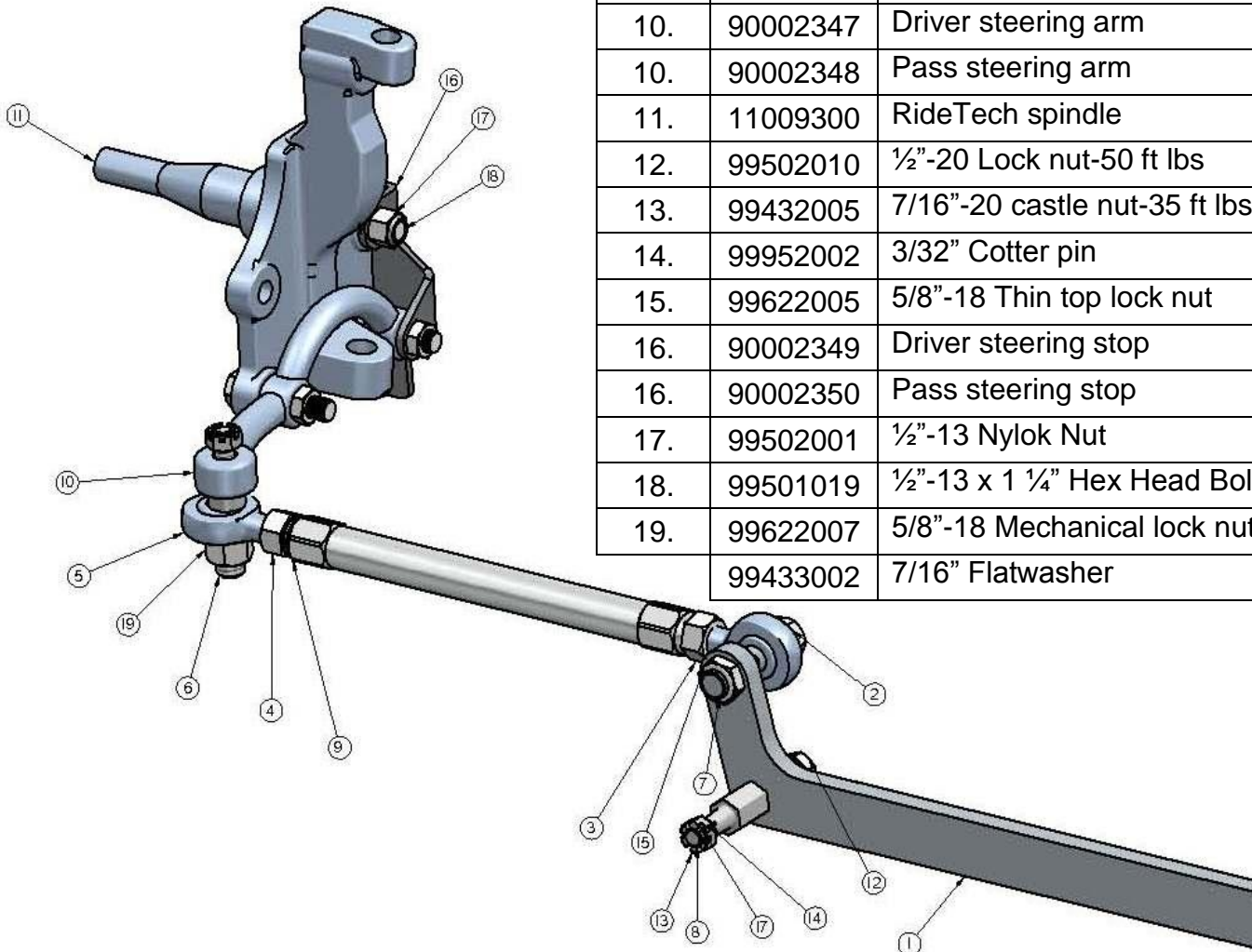



350 S. St. Charles Street Jasper, In. 47546 www.ridetech.com

THIS SYSTEM WILL ONLY WORK WITH RIDETECH STRONG ARMS

Installation instructions

This kit can be used with the OEM draglink or Borgeson Power Steering Conversion Kit

1. You should be using Ridetech Strong Arms and already have installed them.
2. Assemble the new RideTech draglink adapter bracket onto the OEM draglink with the supplied tapered studs and washers per the enclosed drawings.
3. Install the new RideTech spindles onto the control arms per the enclosed drawings. Ball joint nut torque = 83 ft lbs
4. Install the Steering arm and Steering Stop at the same time. The nuts should be on the frame side of the spindle.
5. Install the remainder of the Tru Turn steering linkage as shown in the attached drawings. **MAKE SURE** that ALL cotter pins are used in the appropriate places and that there is no binding or interference throughout the entire suspension travel.
6. Adjust the camber and toe roughly until you can get the vehicle to a proper alignment shop. The recommended alignment settings are:

Camber - -.5 to -1.5 [within .3 from side to side]

Caster – 4 to 7 degrees positive [run .5 degrees more on pass side to allow for road crown]

Toe - 1/8 to 1/4 toe in

Feel free to experiment with alternative alignment settings that may be more appropriate for your particular driving style.

Installation notes:

- A. The draglink bracket has one attachment hole [A] that is slotted. This is to accommodate the variations in manufacturing and machining processes, as well as any wear that may have occurred to the original draglink since that time.
- B. RideTech has successfully fitted a Baer disc brake system to this spindle. Other brands of disc brake brackets **MAY** need clearancing or adjustment for proper installation. The RideTech spindle duplicates the GM A body and F body bolt pattern for brake bracket installation. You will need 5 on 4.5" bolt pattern to keep it the same as the factory rear.
- C. **MAKE SURE** that the cotter pins are properly installed in all appropriate places [C] to ensure that the castle nuts do not become loose and fail. These are **VERY** important connections!
- D. IF your oem drag link is severely worn at the inner tie rod attachment holes [D] you may need to replace that unit with a new oem style draglink to ensure that the [RideTech supplied] tapered pin adapters **DO NOT** pull through that hole.

ridetech

350 S. St. Charles St. Jasper, In. 47546

Ph. 812.482.2932 Fax 812.634.6632

www.ridetech.com

Note: Due to variances in the thickness of the factory drag link, 7/16" flat washers are provided and may be needed to align the castle nut with the cotter pin hole.

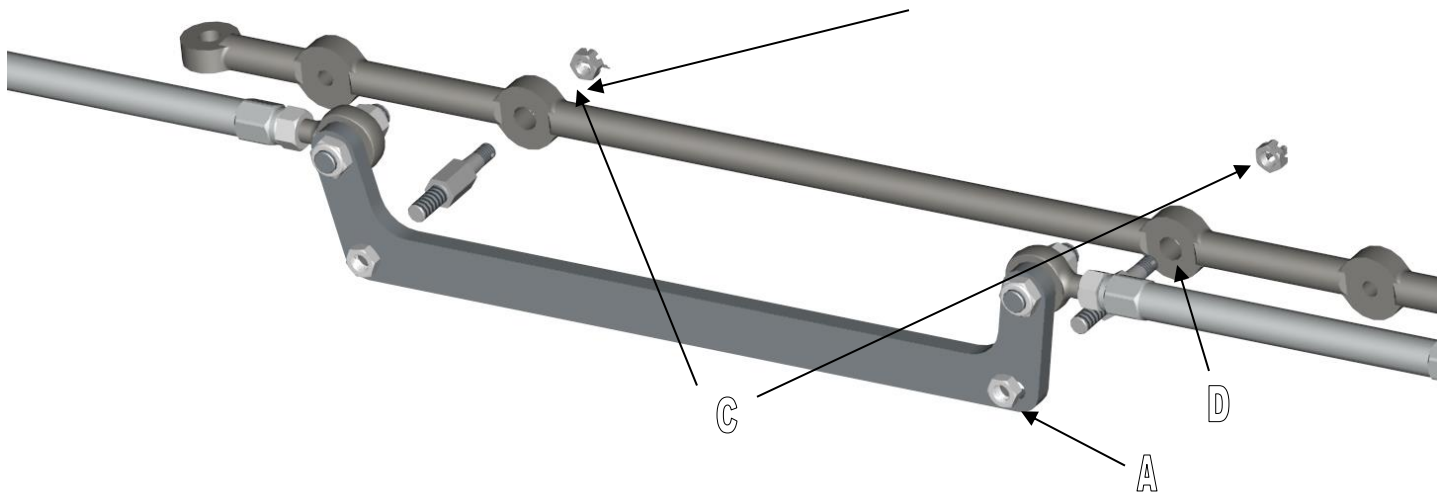

2. The studs with the long hex on them will get installed into the factory draglink with the taper going into the draglink, a 7/16" castle nut is used to attach it to the draglink. Torque the nuts to 35 ft lbs and tighten as needed to align cotter pin hole and install cotter pin. The straight shank will point to the front of the car.

Note: It may be necessary to install 7/16" washers under the castle nut to get the cotter pin engaged properly.

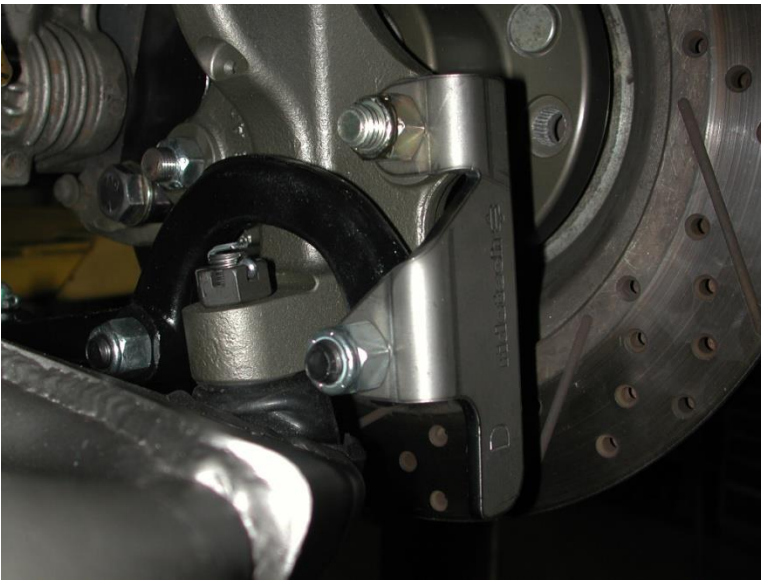

3. Install the Ridetech spindle on the control arms.

4. Install the steering arms and steering stops onto the spindle. The steering arms angles toward the draglink. The steering stops are marked D and P.

The steering arm is attached to the spindle using $\frac{1}{2}$ "-20 x $2\frac{1}{2}$ " Flat Socket Cap Bolts and Nylok nuts.

The upper tab of the steering stop is attached to the spindle using $\frac{1}{2}$ "-13 x $1\frac{1}{4}$ " Hex head bolt and Nylok.



5. Install the stud with the round flange into the steering arm with the taper going into the steering arm. Torque the nuts to 35 ft lbs and tighten as needed to align cotter pin hole and install cotter pin.

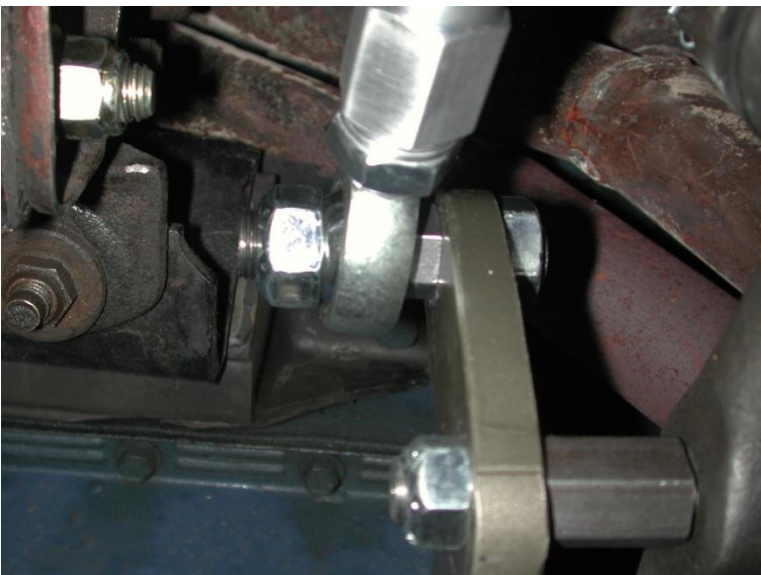

6. The studs with the short hex get installed into the draglink adapter. The short side goes into the adapter attached with the $\frac{5}{8}$ "-18 thin top lock nut, with the long side of the stud pointing forward.

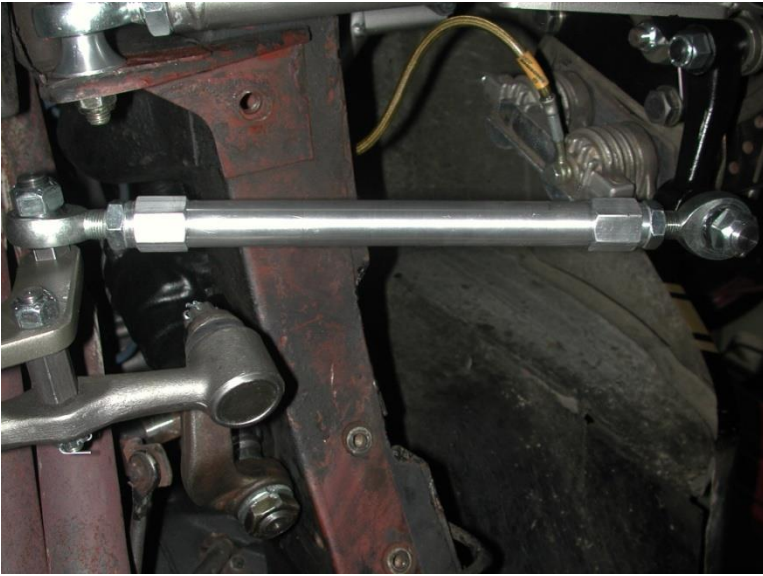

7. The tie rod can now be assembled to a center to center length of 14 1/4" to start with having equal amount of threads on both ends. These Aluminum adjusters have a left hand thread on one end and a right hand thread on the other. You should use antiseize when threading the heim ends into the adjuster.

8. Install the tie rod assembly onto the studs using the 5/8"-18 lock nuts.



Note: If using a factory style stamped caliper bracket, the bracket may need to be trimmed. The dust shield may also need to be modified.



350 S. St. Charles St. Jasper, In. 47546
 Ph. 812.482.2932 Fax 812.634.6632

www.ridetech.com

Brake Kits

The Mustang TruTurn Suspension package uses a GM Spindle used on 67-69 F body, 64-72 A body, and 68-74 X body. Any brake kit designed for this spindle will work it just needs a **4 ½" on 5 bolt pattern** to keep the same bolt pattern as the rear of the Mustang.

We had worked with Baer and Wilwood to put together brake kits for our suspension. Both companies have brake kits that will work with your car, depending on wheel size and your braking needs. We have listed the basic brake kit and each company offers options for their brake kits.

Contact info:

Baer- Phone: 602-233-1411, Web- www.baer.com

Wilwood- Phone: 805-388-1188, Web- www.wilwood.com

Baer Brake Kits:

Minimum Wheel Size	Baer Part #	Brake Kit Name	Description
15" and bigger (some 14")	4301503	SS4+	4 piston caliper / 11" 2 piece rotor
16" and bigger	4301504	T4	4 piston caliper / 13" 1 piece rotor
	4301505	Pro 13	6 piston caliper / 13" 1 piece rotor
	4301506	Pro+13	6 piston caliper / 13" 2 piece rotor
17" and bigger	4301507	Pro+14	6 piston caliper / 14" 2 piece rotor
	4301508	Ext+14	6 piston caliper / 14" 2 piece rotor
18" and bigger	4301509	Ext+15	6 piston caliper / 15" 2 piece rotor

Wilwood Brake Kits:

Minimum Wheel Size	Wilwood Part #	Brake Kit Name	Description
14" and bigger	140-1016	Dyna Pro Single	2 piston caliper / 10" 2 piece rotor
15" and bigger	140-10996	Forged Dynalite Pro	4 piston caliper / 11" 2 piece rotor
	140-7675	Forged Dynalite	4 piston caliper / 12.19" 2 piece rotor
	140-10510	Dyna Pro 6	6 piston caliper / 12/19" 2 piece rotor
17" and bigger	140-12271	Forged Narrow Superlite 6R	6 piston caliper / 12.88" 1 piece rotor
	140-9803	Forged Narrow Superlite 6R	6 piston caliper / 12.88" 2 piece rotor
18" and bigger	140-10920	W6A Big Brake	6 piston caliper / 14" 2 piece rotor
	140-9804	Forged Narrow Superlite 6R	6 piston caliper / 14" 2 piece rotor

As with any brake kit you need to check the template to see if it will clear your wheels. These templates can be obtained by going to the brake manufactures web sites listed above.



350 S. St. Charles St. Jasper, In. 47546
Ph. 812.482.2932 Fax 812.634.6632
www.ridetech.com

Part # 12099100
64-66 Mustang Front MuscleBar

- 1 90002343 Sway Bar (Includes the following)
 - 2 Frame bushing
 - 2 Frame bracket
- 2 90002342 PosiLink spacer
- 2 90000103 PosiLink adapter
- 4 90000926 10mm 90 degree PosiLink
- 1 90001092 Tube of lithium grease

Hardware:

- | | | | |
|---|----------|---|------------------------|
| 4 | 99371003 | 3/8" x 1" USS bolt | Frame bracket |
| 4 | 99372002 | 3/8" USS Nylok nut | Frame bracket |
| 8 | 99373003 | 3/8" SAE flat washer | Frame bracket/PosiLink |
| 4 | 99112002 | 10mm x 1.5 Nylok nut | PosiLink |
| 2 | 99115008 | 10mm x 1.5 x 75mm (3") stud (use Loctite) | |
| 2 | 99622006 | 5/8"-18 Jam Nylok | Posilink adapter |
| 2 | 99623003 | 5/8" Star washer | Posilink adapter |

MUSCLEbar™

POSI•Link™

Installation Instructions

****This sway bar is designed to work with our upper StrongArms****

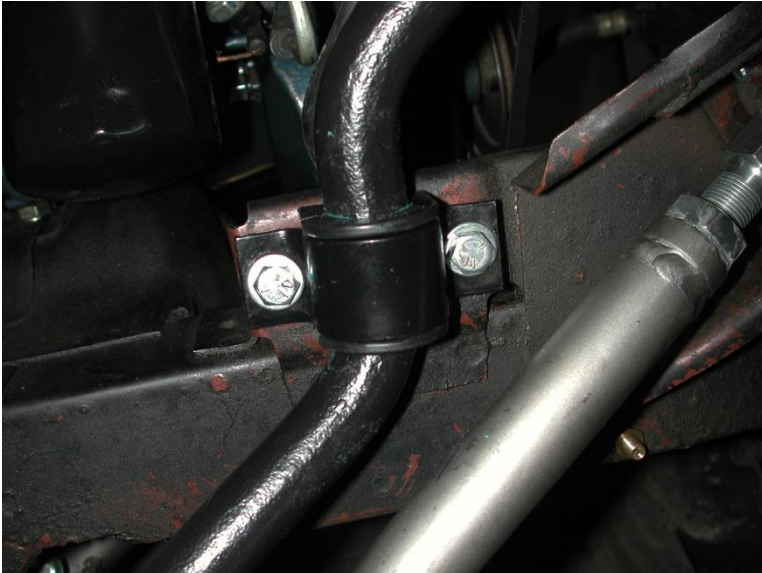

1. Apply lubricant to the poly bushing, then slide it over the sway bar.
2. Place the sway bar frame bracket over the bushing. Bolt the sway bar to the frame using the 3/8" x 1 1/4" bolts, Nylok nut and flat washers supplied.

Note: Do not tighten the frame bolts until after the PosiLinks are installed.



3. Attach the 90 degree end of the PosiLink to the front tab of the upper control arm using a 10mm Nylok nut and a 3/8" flat washer on each side of the tab. The nut will be towards the front of the car with the lower nut towards the frame.

Drivers side shown in picture.



4. Install the PosiLink adapter on to the sway bar end. Install the star washer between the adapter and the sway bar with the Nylok on the bottom of the swaybar.

5. Install the Posilink into the adapter with the nut towards the frame of the car.



5. The frame bolts can now be tightened.

6. Check sway bar and PosiLink clearance through full suspension travel.

7. Ensure that the PosiLinks do not bind through full suspension travel.

Pass side control arm shown in picture.





Part # 12087199 -1965-1970 Mustang Rear Bolt-in 4 Link

Recommended Tools

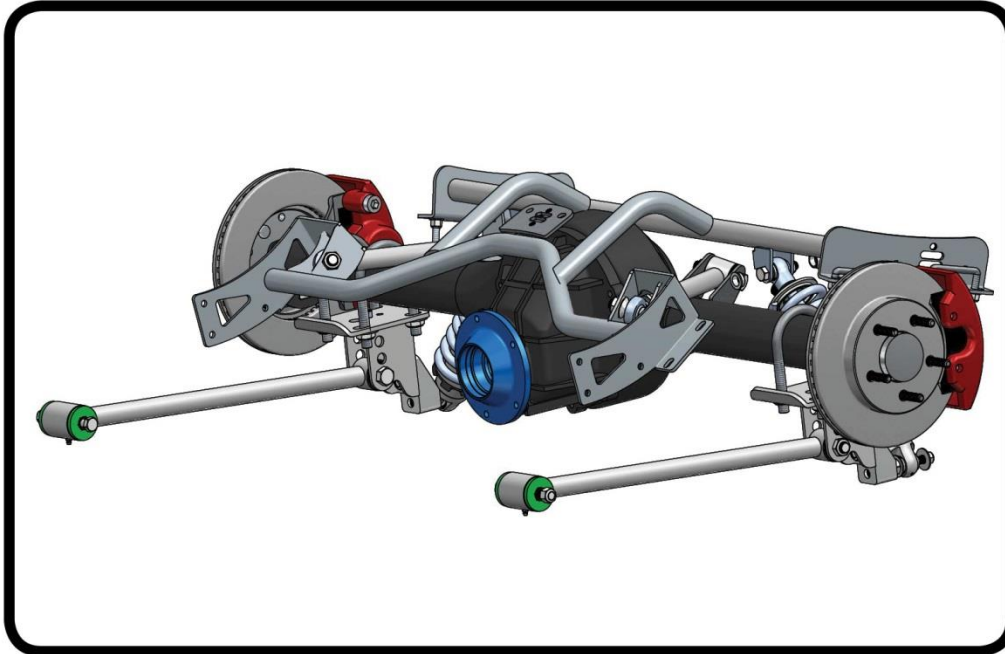

1965-1970 Mustang Rear Bolt-in 4 Link Installation Instructions

Table of contents

- Page 2..... Included components
- Page 3..... Hardware List and Getting Started
- Page 4..... Cradle Installation
- Page 5..... Lower Axle Mount & Lower Bar Installation
- Page 6..... Setting Pinion Angle
- Page 7..... Upper Bar Axle Tab Installation
- Page 8..... Installing Axle Tabs
- Page 9..... Installing ShockWaves/CoilOvers





Major ComponentsIn the box

Item #	Part #	Description	QTY
1	90002198	Upper Cradle	1
2	90000615	Lower Axle Mount	2
3	90002843	Lower Bar Assembly - 21 3/4" center to center	2
4	70013767	Front Lower R-Joint Spacer	4
5	90002844	Upper Bar - 11 3/4" center to center	2
6	70013364	RH R-Joint Threaded Housing End (installed in upper bars)	2
7	70011897	Inner Upper Bar Tab - Tall	2
8	70012018	Outer Upper Bar Tab - Short	4
9	90001642	Aluminum Lower Shock Mount	2
10	90001617	Lower Shock Stud	2
11	70013334	R-Joint Spacers	12
12	90002285	Square U-Bolts	7
13	99566001	Axle U-Bolts (+99566002 & 99566003)	4
14	99752004	3/4"-16 Jam Nut (installed on upper bar Heim)	2
	90002067	Lower Shock Spacers	4
	70010694	Bar Tab Setting Jig	2
R-Joint Components - (Installed in bar ends)			
	70013279	Retaining Ring	8
	70013280	Wavo Wave Spring	8
	70013275	R-Joint Center Ball	8
	70013276	R-Joint Composite Center Ball Cage	8

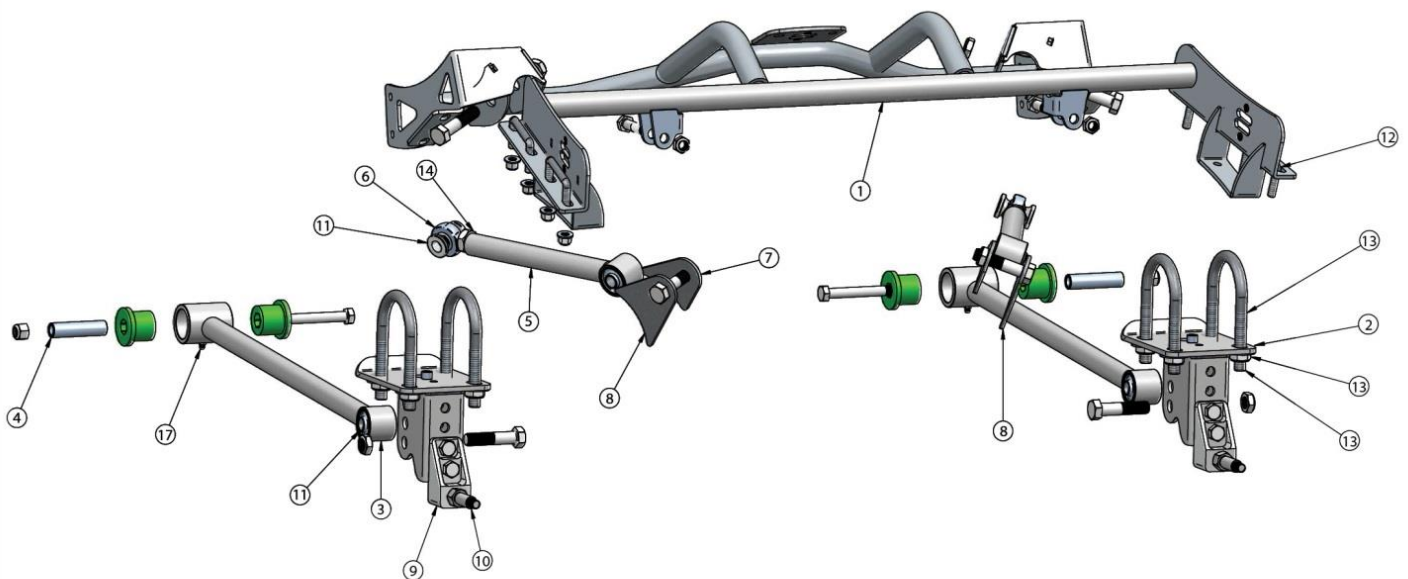



Hardware ListIn the box (Kit# 99010054)

QTY	Part Number	Description	QTY	Part Number	Description
4-Link Bars to Mounts			Shock to Cradle		
6	99621003	5/8" x 2 3/4" Gr. 8 Bolt	2	99501010	1/2" -20 x 2 1/4" Hex Bolt
6	99622006	5/8" SAE Nylok Jam Nut	2	99502003	1/2" -20 Thin Nylok Jam Nut
Cradle to Car			Front Lower bar to Chassis		
14	99372002	3/8-16" Nylok Nut	2	99501029	1/2" -20 x 6 1/2" Hex Bolt
14	99373003	3/8" SAE Flat washer	2	99501017	1/2" -20 x 4 1/2" Hex Bolt
6	99373007	3/8" -16 Thread Forming Bolts	2	99502002	1/2" -20 Nylok Nut
Shock Mount to Axle Mount			Bar Setting Jig		
2	99501007	1/2" -20 x 1 1/4" Hex Bolt	2	99371001	3/8" -16 x 3/4" Hex Bolt
2	99501009	1/2" -20 x 1 3/4" Hex Bolt	2	99372004	3/8" -16 Hex Nut
4	99502002	1/2" -20 Nylok Nut			

R-JOINT SPACER INSTALLATION

Install the Spacers by inserting the SMALL side of the SPACER into the Center Pivot Ball. Push them in until they bottom out and stop.

LOWER FRONT R-JOINT

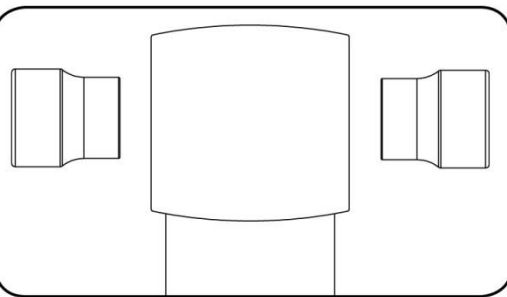

ALL OTHER R-JOINTS

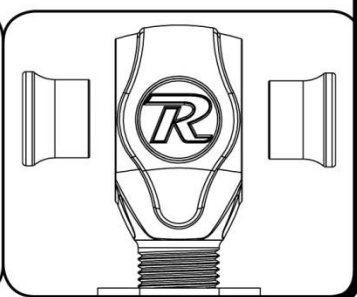

New R-Joints will be quite stiff (75-90 in/lbs breakaway torque) until they "break in" after a few miles of use. After the break in period they will move much more freely. Because the composite bearing race contains self lubricating ingredients, no additional lubrication is needed or desired. Any additional lubrication will only serve to attract more dirt and debris to the R-Joint and actually shorten its life.

Getting Started.....

Congratulations on your purchase of the Ridetech Rear 4-link System. This system has been designed to give your Mustang excellent handling along with a lifetime of enjoyment. Some of the key features of this system: Tune ability, Replaces the Leaf Springs, this allows the 4-Link to locate the rearend and the CoilOvers/ShockWaves to support the car.

Note: These system is designed for use with the Ridetech Shockwaves or CoilOvers and the MuscleBar swaybar. **The factory shocks and springs will not fit this setup.**

1. Raise the vehicle to a safe and comfortable working height. Use jack stands to support the vehicle with the suspension hanging freely.
2. Support the axle and remove the leaf springs, shocks and tail pipes. Refer to the factory service manual for proper disassemble procedures. You might have to detach the fuel line form the frame rails.



Cradle Installation

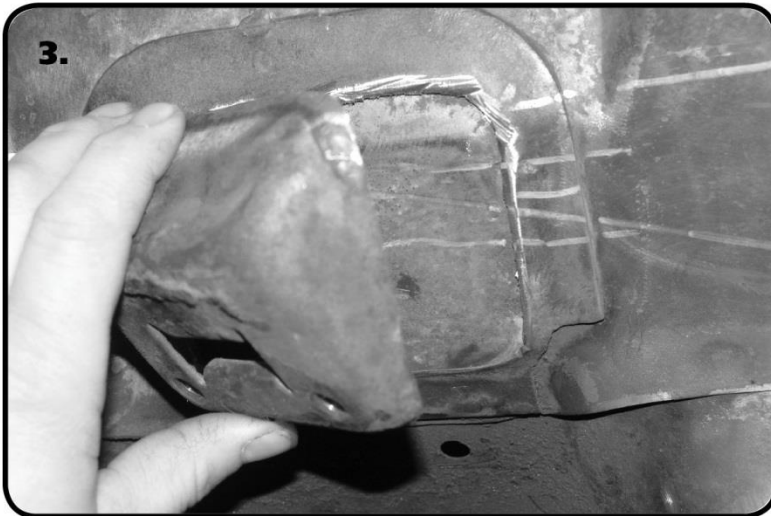

3. Remove the Factory Pinion Snubber and Mount from the car. We use a cut off wheel to remove the mount. Notice that we left the mounting lip of the mount attached to the car. This provides another layer of metal for the Front Tab of the Upper Cradle to attach too.

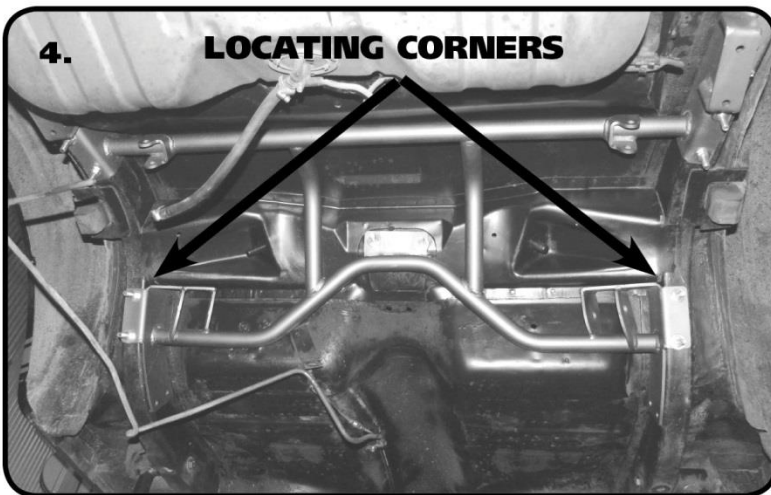

4. Install the cradle into the car. The rear corners of the Upper Bar Mounts locate into the front corner of the factory shock sheet metal mount. The Cradle is held in by (7) 3/8" Square U-bolts. Use the Cradle as a locator for drilling the holes. Drill the holes using a 7/16" drill bit. Drill The front 3 holes on each side with a 5/16" drill bit.

Note: The OEM fuel line will need to be detached from the frame rails until the Cradle is installed.



5. You will notice that the holes are drilled in pairs. Each pair will receive a Square U-bolt. To insert the Square U-bolts into the holes it may be necessary to lower the Cradle to install them. The U-bolts are installed by inserting one end into one of the drilled holes, using the other end as a handle, feed it through the frame until the inserted end will drop down through the remaining hole. Do this for all (7) U-bolts. Install the Cradle into position. Install (1) 3/8" Flat washer and (1) 3/8" Nylok nut onto each stud sticking through the cradle. Do not tighten them until all Washers and Nuts are installed. Install the 3/8" Thread Forming bolts into the 5/16" holes.



Lower Axle Mount & Lower Bar Installation

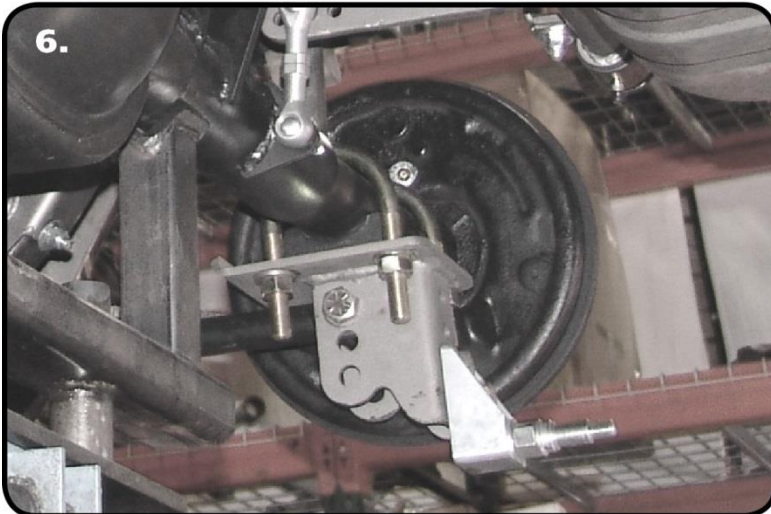

6. Install the Lower Axle Mount onto the Axle using the supplied U-Bolts. Run the nuts down to hold the mount in place, but **DO NOT** tighten yet.

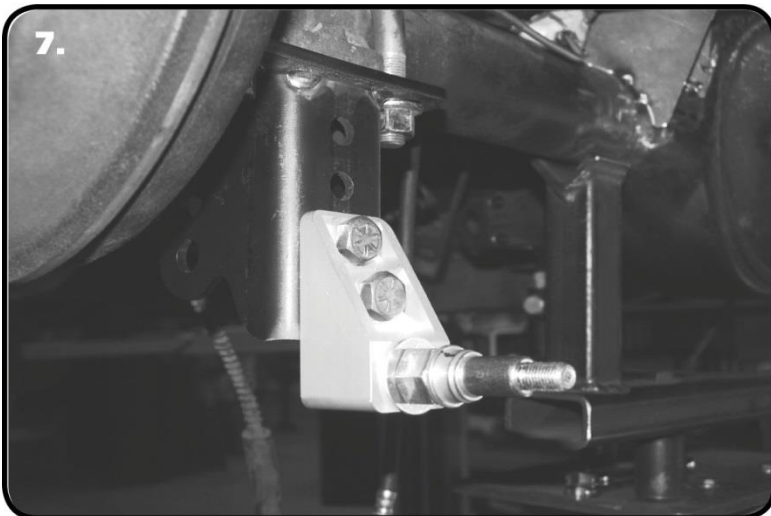

7. Attach the Lower Shock Mount to the Axle Mount using (1) 1/2"-20 x 1 1/4", (1) 1/2"-20 x 1 3/4" Hex Bolts, and (2) 1/2"-20 Nylok Nuts on each mount. The Shock Mount is installed in the **BOTTOM** 2 holes of the Axle Mount. Install a Shock Stud and 5/8" washer in each Shock Mount. Tighten the mounting hardware and the Shock Stud.

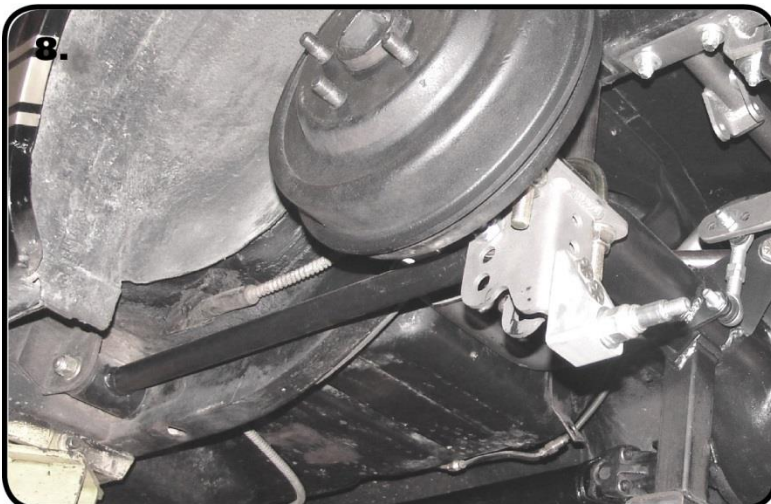

8. Install the Lower Bars. The Front Lower uses the **WIDE**(70013767) R-Joint Spacers inserted into each side of the R-Joint. The Axle end of the bar gets a **NARROW**(70013334) R-Joint Spacer inserted into each side of the R-Joint. The bar is attached to the Axle Mount in the **TOP HOLE** using (1) 5/8" x 2 3/4" Hex Bolt, and (1) 5/8" Thin Nylok Jam Nut. The front of the Lower Bar is attached with 1/2"x 6" Hex Bolt(64-67) or 1/2"x 4 1/2"Hex Bolt(68-70), and (1) 1/2" Nylok Nut.



Setting Pinion Angle

READ PAGES 6-8 ON SETTING PINION ANGLES, UPPER BAR TAB JIG INSTALLATION, & SETTING RIDE HEIGHT.

How do you set the pinion angle? On a single-piece shaft you want to set it up where a line drawn through the center of the engine crankshaft or output shaft of the transmission and a line drawn through the center of the pinion are parallel to each other but not the same line.

Your transmission angle should be around 3 degrees down in the rear. If it is more or less than 3 degrees, you might want to consider changing it. Too little angle on the transmission reduces the amount of oil getting to the rear bushing. Too much transmission angle will increase the working angles of the u-joints which will increase the wear. With the transmission at 3 degrees down in the rear, you will want to set the pinion 3 degrees up in the front.

A simple way to do this is to place a digital angle finder or dial level on the front face of the lower engine pulley or harmonic balancer. This will give you a reading that is 90 degrees to the crank or output shaft unless you have real problems with your balancer. At the other end, you can place the same level or angle finder against the front face of the pinion yoke that is also at 90 degrees to the centerline. If you rotate the yoke up or down so both angles match, you have perfect alignment.

Road testing will tell you if you have it right. If you accelerate and you get or increase a vibration, then the pinion yoke is too HIGH. Rotate it downward in small increments of a degree or two until the problem goes away. If you get or increase a vibration when decelerating, then the pinion yoke is too LOW. Rotate it upward to correct it.

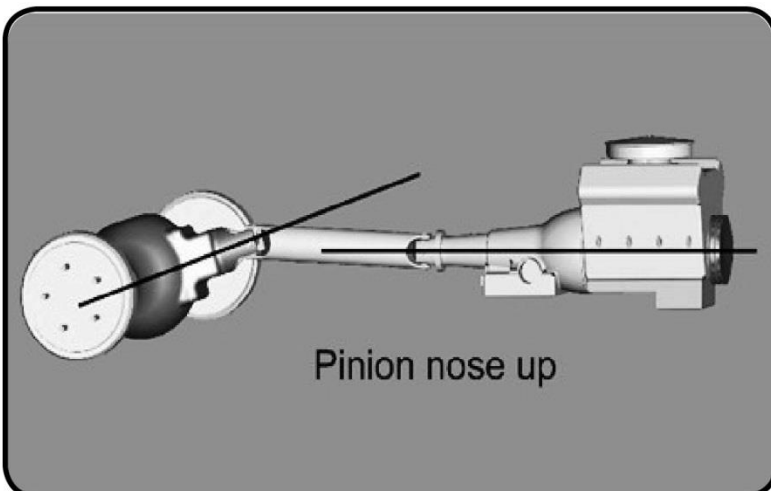
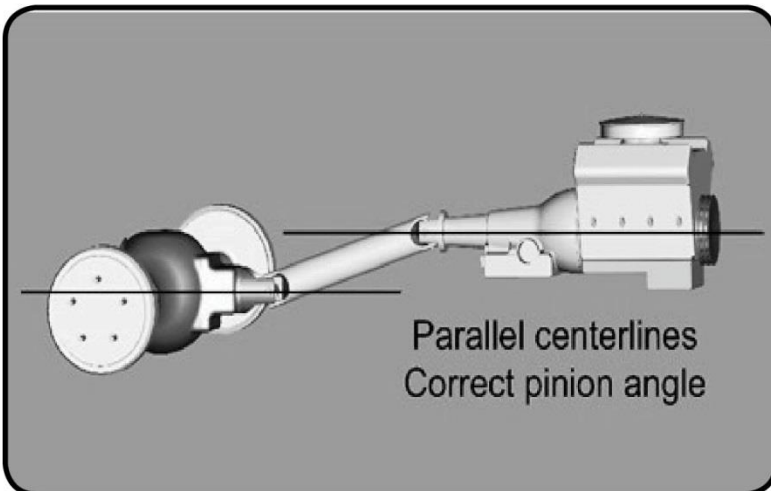
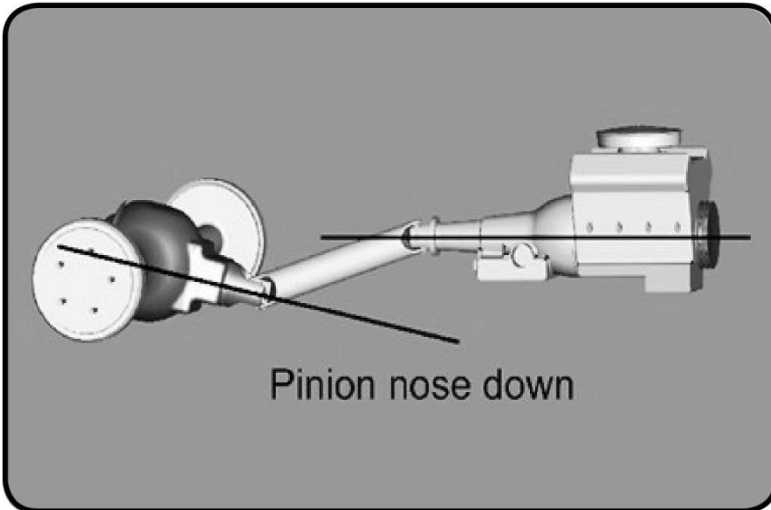



Upper Bar Tab Installation Jig

Upper Bar Installation Jig

- This jig has been supplied to aid in the installation of the upper 4 link bar. It can be temporarily used to properly align, locate and weld the tabs onto the axle. It will also ensure that the mounting bolts are parallel to the ground.
- Follow the diagram below to set the jig to the same length as the upper bar, use the 3/8" x 3/4" bolt and nuts to set the length.
- Position the axle at ride height. Center the axle left to right between the quarter panels. Set pinion angle.
- Bolt one end of the jig to the cradle using a 5/8" x 2 3/4" bolt.
- Using another 5/8" x 2 3/4" bolt, fasten the axle tabs to the other end. The tall tab goes to the outside of the car. The short tab goes to the inside of the car. The tabs must be bolted to the outside of the jig.
- Swing the bar down letting the tabs rest onto the axle. Trim the brackets as necessary to minimize the gap to be welded.
- Check pinion angle, ride height and axle center. Tack-weld the tabs in place.
- Remove jig and install upper bar.
- Repeat this process for the other side.
- Recheck pinion angle, ride height and axle center. (Sound familiar?)
- After the tabs have been tack welded on both sides, remove the upper bars to avoid melting the rubber bushings. Let the axle drop down for better access to the tabs. Lay 1" welds on the inside and outside of the tabs. Skip around from one side to the other to avoid overheating the tube.

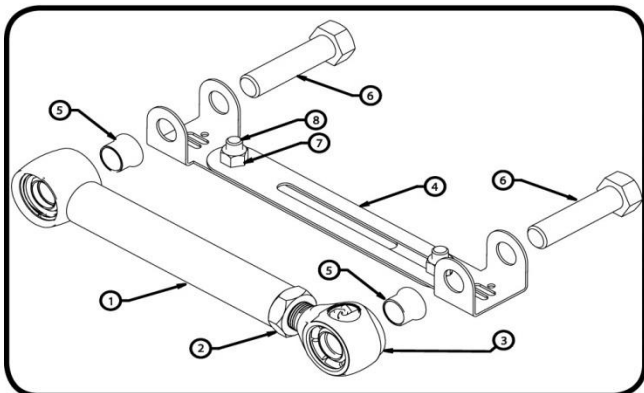

Item#	Description
1	Upper Bar
2	3/4"-16 Jam Nut
3	Heim End
4	Alignment Jig
5	Aluminum Spacer
6	5/8" x 2 3/4" Bolt
7	3/8"-16 Nut
8	3/8"-16 x 3/4" Bolt



Installing Axle Tabs

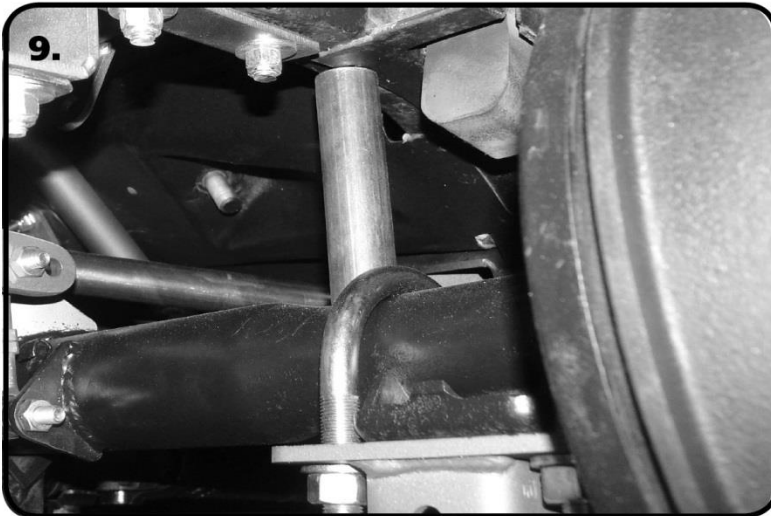

9. One helpful trick to maintain ride height when setting the pinion angle is to put a spacer between the axle and the frame. The spacer should be 4 1/2" tall. Set the pinion Angle and axle center. When measuring the axle center you can measure off of the frame rails. We also use a plum bob off the quarter panels to double check the axle center. Refer to Page 6 on Setting the Pinion Angle.

Note: You can tack weld the spacer in place after you get the Pinion Angle, and Axle Center set. This will ensure that nothing moves through the Upper Tab Installation.

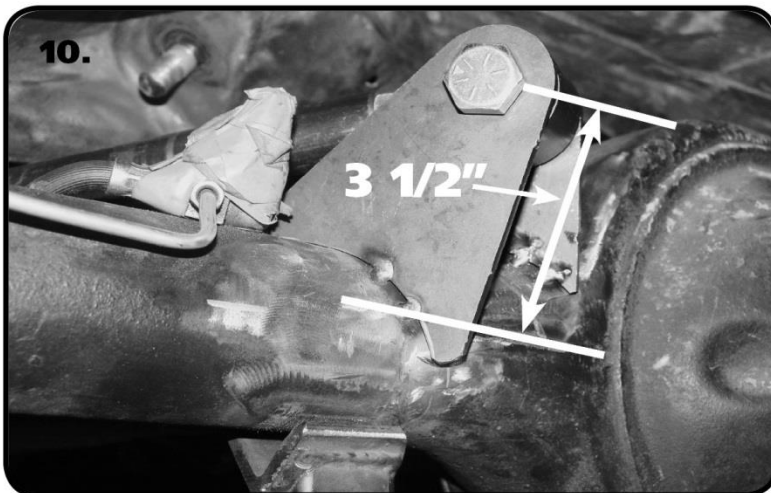

10. Refer to Page 7 and set the length of the Upper Bar Jig and install the Tabs on the Jig. Insert the Jig into the Cradle. Set the Upper Tabs on the Rearend. Due to different variations of the Rearend Housings, it may be necessary to modify the tabs for the best fit. The height you are wanting to achieve with the upper bar end is 3 1/2" from the axle center line. Modify the tabs so that the center of the bar bushing will be 3 1/2" from the center of the axle.

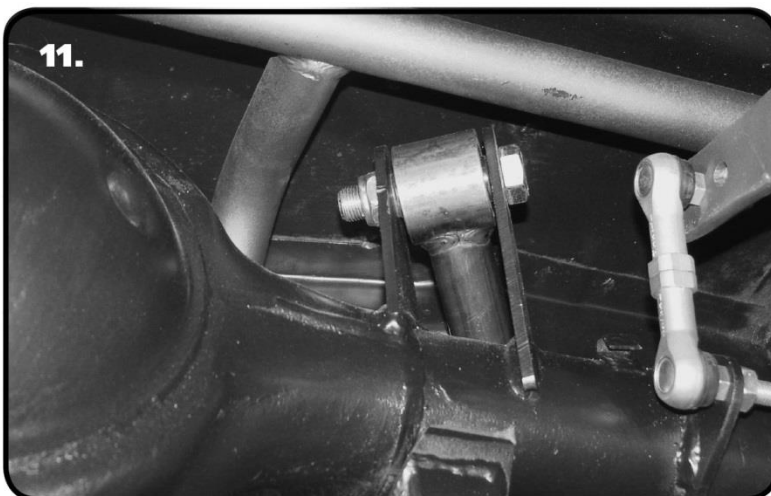

11. Once the bar end height is set, tack weld the tabs to the axle. Do this for the Driver and Passenger side bars. Insert the bars into the Cradle and Tabs to double check fitment. Recheck Axle Center and Pinion Angle. Once satisfied with fitment weld the Upper bar Tabs onto the Axle. Weld 1" at a time, skip around from one side to the other, and one tab to the other to avoid overheating the Axle Tube. When the tabs cool down, insert NARROW(70013334) spacers into each side of the R-Joints of the Upper Bar. Attach the upper bars using (1)5/8" x 2 3/4" Bolt, and (1) 5/8" Thin Nylok Nut.



Installing Shockwaves/Coilovers

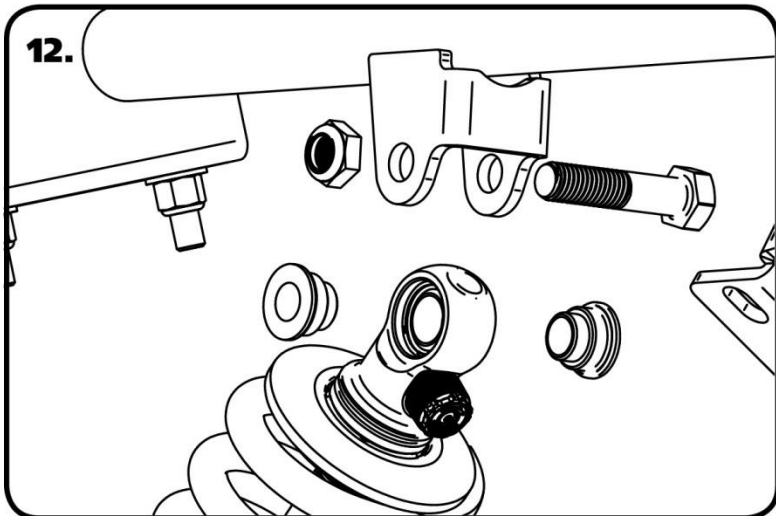

Remove the Spacer from between the Axle and Frame.

12. Install a 1/2" ID Spacer on each side of the upper Coilover/ShockWave. Slide the assembly into the upper crossmember from the bottom side. If your shock has an adjuster knob position it so that the knob points toward the center of the car. Line up the hole in the spacers with the hole in the upper shock bridge and insert 1/2" x 2 1/2" bolt and install 1/2" Nylok nut.

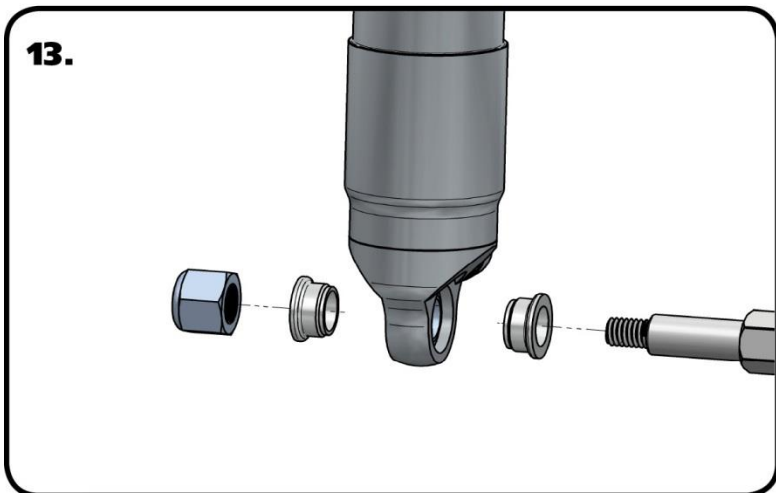

13. Install a 5/8" ID spacer(Small side towards shock body) onto the lower Shock Stud. Slide the bottom of the Shock onto the Stud. Install a second 5/8" ID Spacer onto the Stud(small side towards shock). You may need to jack the rearend up to Slide the Shock onto the Stud. Install the 7/16" Flatwasher and 7/16" Nylok nut. Tighten the upper and lower shock bolts.

Note: If installing Shockwaves and you want to locate the air fitting in a different location, the air spring assembly can be rotated on the shock by grabbing the shock and air spring assembly by hand and spinning the shock in the air spring assembly.

The designed ride height of the CoilOver/Shockwave is 14 1/2" center to center.

STILL HAVE QUESTIONS?

Tech line hours

Monday - Friday

8AM - 6PM (EST) 812-482-2932



350 S. St. Charles St. Jasper, In. 47546

Ph. 812.482.2932 Fax 812.634.6632

www.ridetech.com

Should I weld my AirBar 4 link assembly in?

Since we get this question quite often, it deserves a proper explanation.

The AirBar has been designed for bolt-in installation. We have paid special attention to interfacing with key structural areas of each vehicle, fastening bracketry in at least two planes to properly distribute load paths, and to using appropriate fasteners that roll, rather than cut, threads into the vehicle structure.

Having said that, you could potentially encounter a vehicle that has rust or collision damage in these areas. Or maybe you intend to consistently place the vehicle in severe racing applications with sticky racing slicks and high speed corners. In these cases it is perfectly acceptable to weld the AirBar components into your vehicle. Even in these severe cases we recommend that you install the entire AirBar assembly first [including the fasteners], and then use short 1" long tack welds to secure your installation. Remember that the vehicle structure metal is typically much thinner [.060"-.120"] than the .188" thick AirBar brackets. If you burn through the vehicle sheet metal structure you may end up with an installation that is weaker than before you tried to weld it.

The other reason to weld in your AirBar assembly is...you simply want to. You're a welding kind of guy...that's the way you've always done it...you have the skills and equipment to do it. In that case...weld away with our blessing!



350 S. St. Charles St. Jasper, In. 47546

Ph. 812.482.2932 Fax 812.634.6632

www.ridetech.com

Part # 12096510
64-66 Mustang HQ Series Rear Coil-Overs
For Use w/ RideTech 4 Link

Shock Assembly:

- | | | |
|---|----------|---------------------------------|
| 2 | 24059999 | 5" stroke HQ Series shock |
| 2 | 90002021 | 1.7" eyelet – Single Adjustable |
| 4 | 90001994 | .625" I.D. bearing |
| 8 | 90001995 | Bearing snap ring |

Components:

- | | | |
|---|----------|-------------------------------------|
| 2 | 59120150 | Coil spring – 12" long / 150 # rate |
| 2 | 90002222 | Spring retainer kit |
| 8 | 90002043 | Aluminum spacer for bearings |

Assembly...



First using the supplied lower adjuster nut(90002222) thread the nut onto the shock from the bottom side as seen in figure 1



Next install delrin washers then coil spring over the top of the shock as seen in figure 2



Before the upper spring mount can be installed screw the adjuster knob on the upper eye mount to the firmest setting (clockwise) as seen in figure 3.



Slide the Derlin washer over the spring, Next slide the upper spring mount (90002222) over eyelet as seen in figure 4.



Install upper spring mount retainer clip (90002057) into the groove on the upper eyelet as seen in figure 5. Then reinstall adjuster to complete assembly.



The included set of bearing spacers (900002044) are used to adapt the coil-overs to just about any application. The supplied spacers allow the coil-overs to accept 5/8" or 1/2" bolts.

Shock adjustment 101- Single Adjustable

Rebound Adjustment:

How to adjust your new shocks.

The rebound adjustment knob is located on the top of the shock absorber protruding from the eyelet.

You must first begin at the ZERO setting, then set the shock to a soft setting of 20.



-Begin with the shocks adjusted to the ZERO rebound position (full stiff). Do this by rotating the rebound adjuster knob clockwise until it stops.



-Now turn the rebound adjuster knob counter clock wise 20 clicks. This sets the shock at 20. (settings 21-24 are typically too soft for street use).

Take the vehicle for a test drive.



-if you are satisfied with the ride quality, do not do anything, you are set!



-if the ride quality is too soft increase the damping effect by rotating the rebound knob clock wise 3 clicks.

Take the vehicle for another test drive.



if the vehicle is too soft increase the damping effect by rotating the rebound knob clock wise 3 additional clicks.



-If the vehicle is too stiff rotate the rebound adjustment knob counter clock wise 2 clicks and you are set!

Take the vehicle for another test drive and repeat the above steps until the ride quality is satisfactory.

Note:

One end of the vehicle will likely reach the desired setting before the other end. If this happens stop adjusting the satisfied end and keep adjusting the unsatisfied end until the overall ride quality is satisfactory.