



350 S. St. Charles St. Jasper, In. 47546  
Ph. 812.482.2932 Fax 812.634.6632

[www.ridetech.com](http://www.ridetech.com)

**Part # 12090298**  
**64-66 Mustang Air Suspension System**

**Front Components:**

1	12093001	HQ Series Front Shockwaves
1	12099599	Front Tru-Turn Suspension Package
1	12099100	Front MuscleBar

**Rear Components:**

1	21150701	HQ Series Rear Shockwaves
1	12087199	Bolt-on 4 Link



**Part # 12093001** - 64-66 Ford Mustang Front HQ Shockwave, for StrongArms

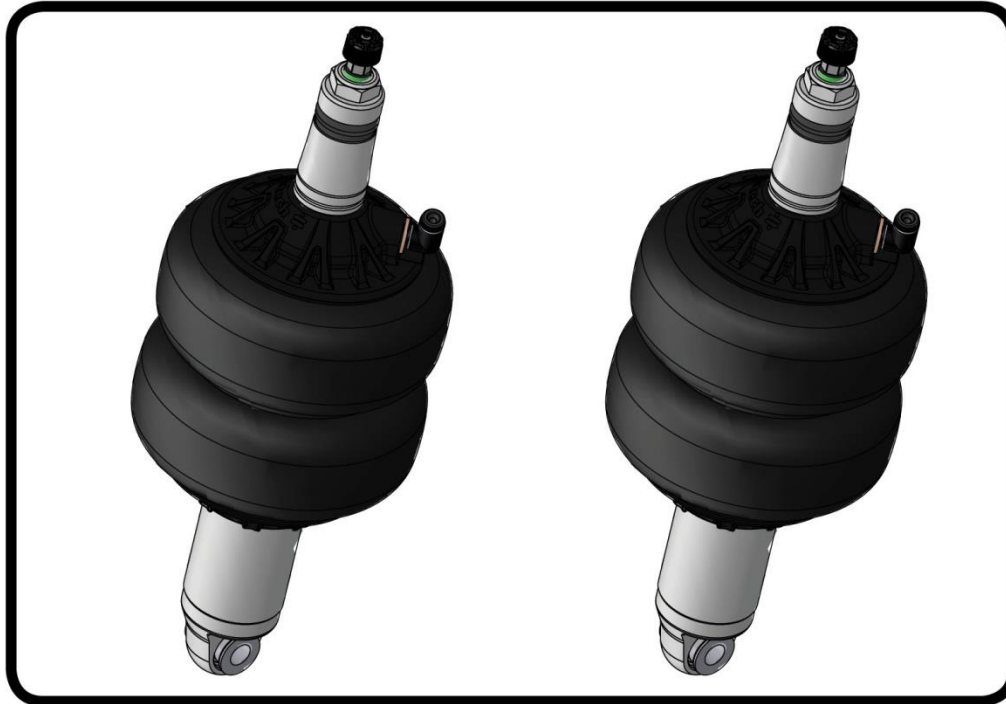

Recommended Tools



## 1000 Series Bellow, 2.0" Stud/Eye 3.6" Shock Installation Instructions

*THESE SHOCKWAVES ARE DESIGNED TO BE USED WITH RIDETECH STRONGARMS*

### Table of contents

Page 2..... Included components

Page 3-4..... Shockwave Installation

Page 5-6..... Notes and Care of Your Shockwave & Shock Adjustment

### ShockWave Dimensions:

#### Mount to Mount:

Compressed: 10.30"

Ride Height: 12.13"

Extended: 13.32"

www.ridetech.com  
812-482-2932





### Major Components .....In the box

Item #	Part #	Description	QTY
1	24139999	3.6" Stroke HQ Series Shock	2
2	90009988	2" Stud Top (Installed on Shock) - Includes Adjuster Knob & Screw	2
3	24090199	1000 Series 6.5" Double Convolute AirSpring	2
4	70010893	AirSpring Locking Ring (Installed on shock)	2
5	99055000	Locking Ring Set Screw (Installed on shock)	2
6	90002043	1/2" ID Bearing Spacers	4
7	90002312	2" Aluminum Stud Top Base	2
8	90001904	Bottom Delrin Ball	2
9	90001903	Top Delrin Ball	2
10	90001902	Delrin Ball Aluminum Top Cap	2
11	99562003	9/16"-18 Thin Nylok Nut	2
12	90009972	Adjuster Knob - (90009988 assembly)	2
13	90009969	#4-40 X 1/4" SS, 18-8 Pan Head Torx Cap - (90009988 assembly)	2
14	90002356	Upper ShockWave Mount	2
15	90000563	Aluminum Top Cover Plate	2
	90001994	5/8" ID Bearing (installed in shock and eyelet)	4
	90001995	Bearing Snap Ring (installed in shock and eyelet)	8
	99311012	5/16" X 1" Flange Bolt	6

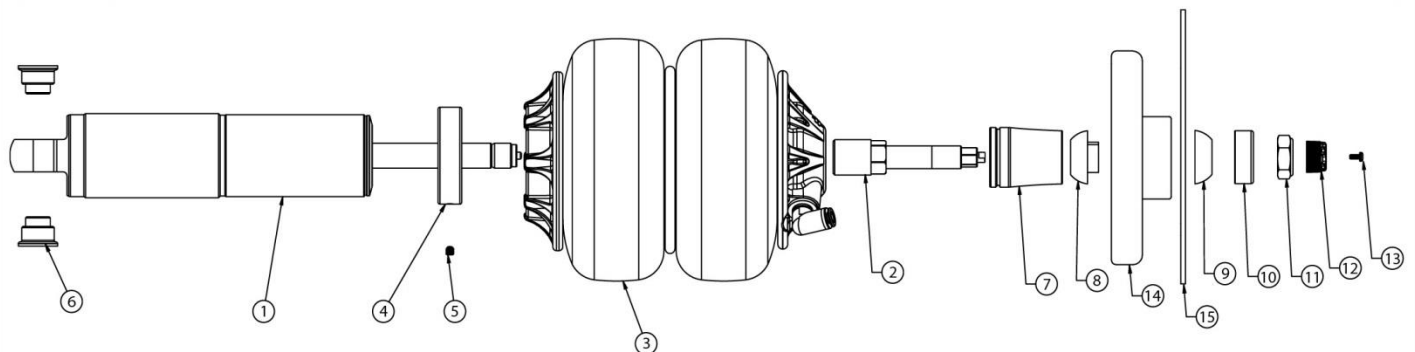

**THE DELRIN BALL REQUIRES A 3/4" HOLE FOR THE FLANGE TO GO THROUGH. THIS CAN BE DRILLED WITH A UNIBIT.**

**WARNING: ATTEMPTING TO REMOVE THE AIR FITTING WILL DAMAGE IT AND VOID THE WARRANTY.**





### ShockWave Installation

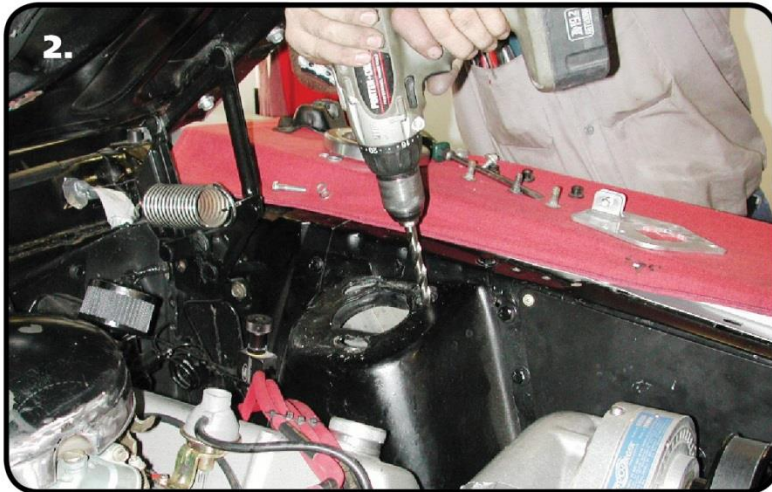

1. Install the Ridetech StrongArms. Also, it is easier to install the ShockWave with the CoilSpring Shield removed.

2. Drill a 3/8" Hole in the CENTER of the large part of the Key Hole Slots. Do this for each Key Hole in the driver and passenger shock towers.



3. Hold the Aluminum Upper Mount against the bottom of the shock tower lining up the threaded holes with the holes drilled in the shock tower.



4. Lay the Upper Plate on Top of the shock tower with the ShockWave Mount protruding through the large center hole. Line up the the holes in the Upper Plate with the holes drilled in the shock tower and the holes in the ShockWave mount. If the INNER Hole doe not line up, flip the plate over. Install a 5/16" x 1" Flange Bolt in each hole and tighten.





### ShockWave Installation

5.

1. Stud top aluminum base
2. Delrin ball lower half
3. Delrin ball upper half
4. Aluminum cap
5. 9/16" SAE Nylok jam nut
6. Threaded stud (screwed onto shock shaft)
7. Rebound adjusting knob
8. Screw

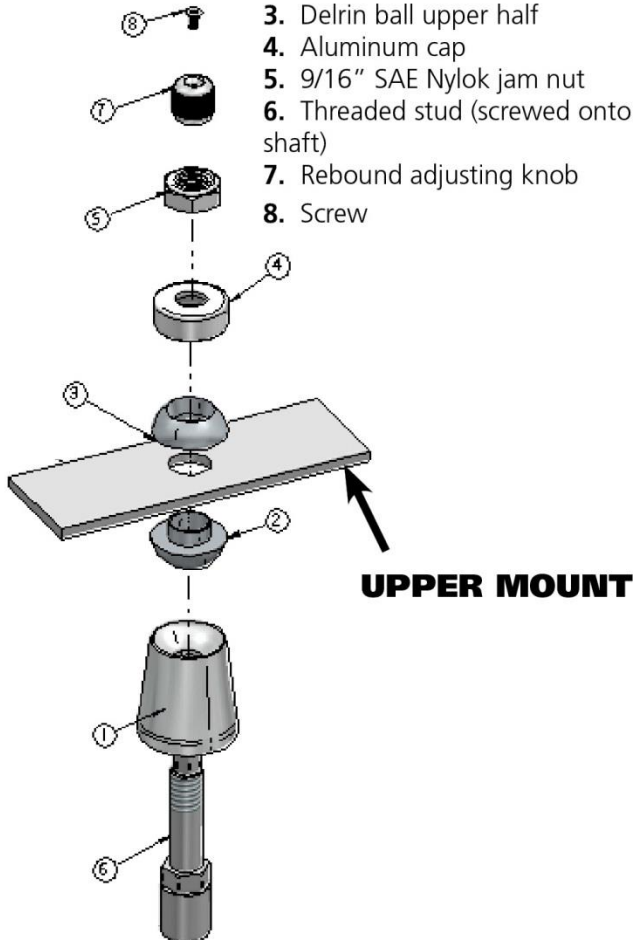

**Note:** The airline must also be routed at this time. It can be ran through the subframe toward the rear of the vehicle.

5. The air fitting location can be rotated by twisting the bellow assembly separate of the shock. Place the Shockwave into the coil spring pocket with the stud sticking through the OEM shock hole. See assembly **Diagram 5**.

1. Stud top aluminum base
2. Delrin ball lower half

#### UPPER MOUNT

3. Delrin ball upper half
4. Aluminum cap
5. 9/16" SAE Nylok jam nut
6. Threaded stud (screwed onto shock shaft)
7. Rebound adjusting knob
8. Screw

6. Install the a Bearing Spacer in each side of the Bearing. The SMALL part of the spacer inserts into the Inside Diameter of the shock bearing. Raise the lower arm up to the Shockwave and bolt them together using the 1/2" x 2 1/2", & Nylok Nuts supplied with the ShockWaves. Torque to 50 ftlbs.

7. Reattach the outer coil spring shield. A hole can be drilled into it to allow airline access to the Shockwave. Use a rubber grommet to prevent airline damage.

**Check air spring clearance through full suspension travel. Allowing the air spring to rub will cause failure and is not a warrantable situation.**

8. Ride height should be around 90 psi but will vary to vehicle weight and driver preference.





### Notes and Care of your Shockwaves

#### NOTES:

**WARNING: ATTEMPTING TO REMOVE THE AIR FITTING WILL DAMAGE IT AND VOID THE WARRANTY.**

**TIGHTENING THE TOP 9/16"-18 NUT:** SNUG THE NUT DOWN AGAINST THE TOP CAP. YOU NEED TO BE ABLE TO ARTICULATE THE SHOCK BY HAND.

You can clock the airfitting location on the ShockWave by turning the AirSpring assembly of the shock. Make sure the fitting doesn't contact the frame.

When cutting the airline, use a razor blade. The cut needs to be a clean cut and square for the airline to seal properly.

The Locking ring on the shock is **NOT** adjustable. These rings are set at the factory to optimize the AirSpring stroke with the shock stroke.

---

## The care and feeding of your new ShockWaves

1. Although the ShockWave has an internal bumpstop, **DO NOT DRIVE THE VEHICLE DEFLATED RESTING ON THIS BUMPSTOP. DAMAGE WILL RESULT.** The internal bumpstop will be damaged, the shock bushings will be damaged, and the vehicle shock mounting points may be damaged to the point of failure. This is a non warrantable situation.
2. Do not drive the vehicle overinflated or "topped out". Over a period of time the shock valving will be damaged, possibly to the point of failure. This is a non warrantable situation! If you need to raise your vehicle higher than the ShockWave allows, you will need a longer unit.
3. The ShockWave is designed to give a great ride quality and to raise and lower the vehicle. **IT IS NOT MADE TO HOP OR JUMP!** If you want to hop or jump, hydraulics are a better choice. This abuse will result in bent piston rods, broken shock mounts, and destroyed bushings. This is a non warrantable situation.
4. Do not let the ShockWave bellows rub on anything. Failure will result. This is a non warrantable situation.
5. The ShockWave product has been field tested on numerous vehicles as well as subjected to many different stress tests to ensure that there are no leakage or durability problems. Failures have been nearly nonexistent unless abused as described above. If the Shockwave units are installed properly and are not abused, they will last many, many years. ShockWave units that are returned with broken mounts, bent piston rods, destroyed bumpstops or bushings, or abrasions on the bellows will not be warrantied.



### Shock Adjustment

#### Shock adjustment 101- Single Adjustable

##### Rebound Adjustment:

How to adjust your new shocks.

The rebound adjustment knob is located on the top of the shock absorber protruding from the eyelet.

You must first begin at the ZERO setting, then set the shock to a soft setting of 20.



-Begin with the shocks adjusted to the ZERO rebound position (full stiff). Do this by rotating the rebound adjuster knob clockwise until it stops.



-Now turn the rebound adjuster knob counter clock wise 20 clicks. This sets the shock at 20. (settings 21-24 are typically too soft for street use).

##### Take the vehicle for a test drive.



-if you are satisfied with the ride quality, do not do anything, you are set!

-if the ride quality is too soft increase the damping effect by rotating the rebound knob clock wise 3 clicks. **CONTINUE ON NEXT PAGE.**

##### Take the vehicle for another test drive.



-if the vehicle is too soft increase the damping effect by rotating the rebound knob clock wise 3 additional clicks.



-If the vehicle is too stiff rotate the rebound adjustment knob counter clock wise 2 clicks and you are set!

Take the vehicle for another test drive and repeat the above steps until the ride quality is satisfactory.

##### Note:

**One end of the vehicle will likely reach the desired setting before the other end. If this happens stop adjusting the satisfied end and keep adjusting the unsatisfied end until the overall ride quality is satisfactory.**

### STILL HAVE QUESTIONS?

#### Tech line hours

Monday - Friday

8AM - 6PM (EST) ..... 812-482-2932



# ridetech



350 S. St. Charles St. Jasper, In. 47546  
Ph. 812.482.2932 Fax 812.634.6632

[www.ridetech.com](http://www.ridetech.com)



## Part # 12099599 64-66 Mustang Tru-Turn Suspension Package

### Front Components:

1	12093699	Upper Strong Arms
1	12092899	Lower Strong Arms
1	12099500	Tru Turn System

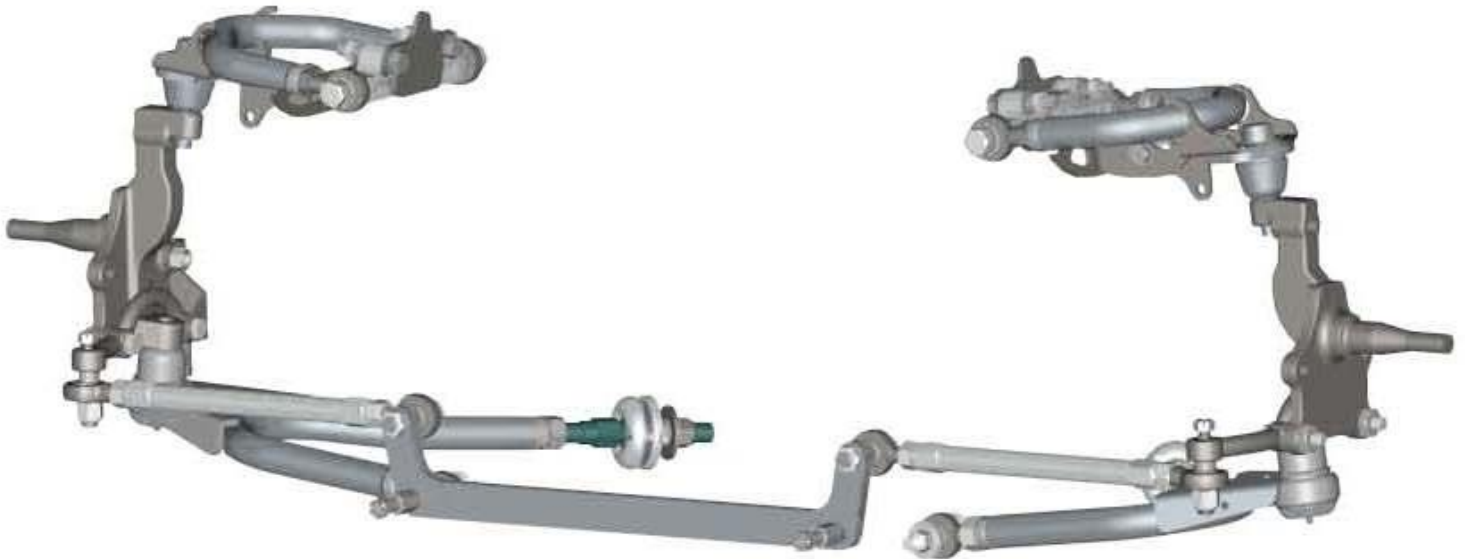



350 S. St. Charles St. Jasper, In. 47546  
Ph. 812.482.2932 Fax 812.634.6632

**Part # 12093699**  
**64-66 Mustang Upper StrongArms**  
For Use w/ Shockwaves or CoilOvers  
Must be Used with Ridetech Tru-Turn Setup

**Components:**

1	90002340	Driver Upper StrongArm
1	90002339	Pass Upper StrongArm
2	70010866	Upper ball joint
2	90002633	Ball joint spacer
2	90009967	Billet Aluminum drop cross shaft
4	90001589	Heim ends – 3/4"-16 thread x 5/8" I.D.
2	90002341	Alignment shim
4	90002043	.500" I.D. Bearing spacer

**Hardware:**

6	99311002	5/16"-18 x 1 1/4" Hex Bolt	Upper Ball joint
6	99312003	5/16"-18 Nylok Nut	Upper Ball joint
12	99313002	5/16" SAE Flat washer	Upper Ball joint
4	99621002	5/8"-18 x 1 3/4" Gr.8 bolt	Rod end to cross shaft
6	99501003	1/2"-13 x 2 1/2" Gr.5 bolt	Cross shaft to body/Shock to upper arm
4	99502006	1/2"-13 nut	Cross shaft to body
8	99503001	1/2" SAE flat washer	Cross shaft to body
4	99503002	1/2" lock washer	Cross shaft to body
2	99502001	1/2"-13 Nylok nut	Shockwave/CoilOver to upper arm
4	99752004	3/4"-16 jam nut	Heim ends

# STRONG ARMS™

by Air Ride Technologies

Item #	Description	Qty.
1.	Control arm	1
2.	Heim ends – 3/4"-16 thread x 5/8" I.D.	2
3.	Alignment shim	1
4.	5/8"-18 x 1 3/4" Gr.8 bolt	2
5.	5/8" lock washer	2
6.	1/2" SAE flat washer	4
7.	5/8" SAE flat washer	2
8.	1/2"-13 x 2 1/2" Gr.5 bolt	2
10.	Cross shaft	1
13.	1/2"-13 Nut	2
14.	1/2"-13 Nylok Nut	2
15.	1/2"-13 x 2 1/2" Gr.5 bolt	1
18.	Ball Joint Spacer	2
19.	5/16" flat washer	6
20.	5/16"-18 x 1 1/4" bolt	3
21.	5/16"-18 Nylok Nut	3

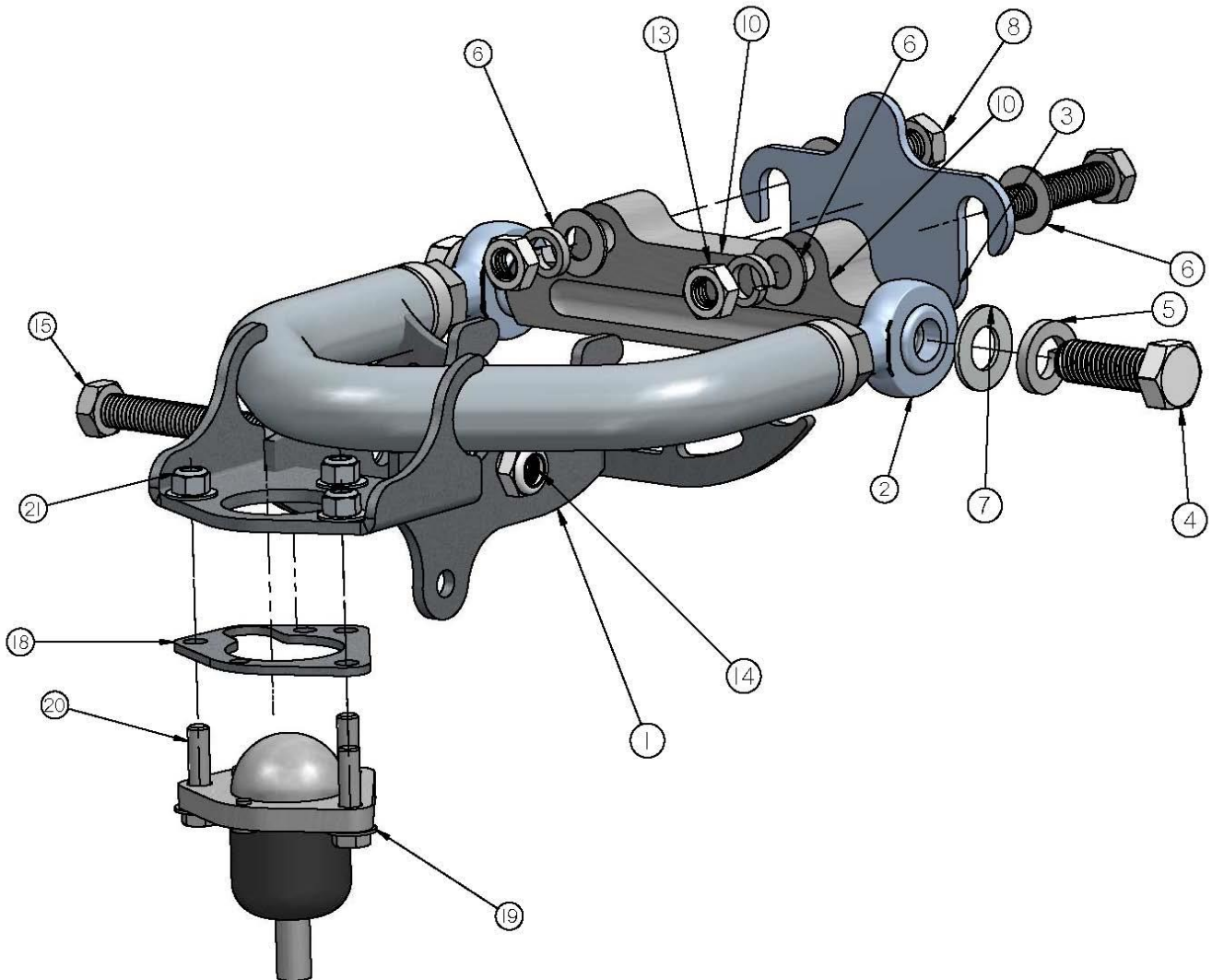



# STRONG ARMS™

by Air Ride Technologies

1. Bolt the Ball Joint to the Control Arm with the BALL JOINT SPACER between the Ball Joint and Control Arm. The Ball Joints/Spacers are attached using (3) 5/16"-18 x 1 1/4" Bolts, (3) 5/16"-18 Nylok Nuts and (6) 5/16" SAE Flat Washers. Do this for both Control Arms. Refer to the Diagram on Page 3.



2. Bolt the upper StrongArm to the body using 1/2" x 2 1/2" bolts, flat washers and lock washers. The **ARROW** points to the front of the vehicle. A shim is supplied and may need to be installed between the body and the arms to achieve proper alignment.

3. The arms are preset at the factory so the alignment should be close, but the vehicle must be aligned before driving.

**Note:** The upper arm mounting holes on many cars have been redrilled 1" lower. This is done to improve the handling. Our cross shaft has the drop built into it; **make sure to use the factory mounting holes.**



4. Bolt the upper arm to the spindle using the hardware and cotter pin supplied.

5. Attach the Shockwave to the upper StrongArm using a 1/2" x 2 1/2" bolt and Nylok nut.

6. This control arm is designed to work with our MuscleBar sway bar. The end link will attach to the **front** mounting tab on the upper arm.



350 S. St. Charles St. Jasper, In. 47546

Ph. 812.482.2932 Fax 812.634.6632

[www.ridetech.com](http://www.ridetech.com)

## Part # 12092899

### 64-66 Mustang Lower StrongArms

To Be Used With Ridetech TRU-TURN

#### Components:

1	90002334	Driver side lower arm
1	90002335	Passengers side lower arm
2	90000898	Lower ball joint
2	90001589	Kevlar lined heim end
4	90002338	Rod End Spacers
2	90001045	Control arm pivot bearing
2	90002336	Bearing housing
2	90002337	Bearing retaining plate
2	90000733	Aluminum bearing spacer
2	90000732	Bearing stud (Set to 2- 7/8")

#### Hardware:

2	99501024	1/2"-13 x 3 1/4" Gr.5 bolt	Lower arm to frame
2	99502001	1/2"-13 Nylok nut	Lower arm to frame
6	99311003	5/16"-18 x 1 1/2 Hex	Bearing housing
6	99313003	5/16" lock washer	Bearing housing
4	99752004	3/4"-16 Jam nut	Stud to arm
2	99752001	3/4"-16 Lock nut	Stud to bearing
2	99753002	3/4" x 2" flat washer	Stud to bearing

## Installation Instructions

1. Raise and support vehicle at a safe, comfortable working height. Let the front suspension hang freely.
2. Remove the coil spring, shock absorber, upper shock bracket, strut rod, sway bar, upper and lower control arms. Refer to factory service manual for proper disassembly procedure.



3. Be sure to remove the outer bushing sleeve from the strut rod frame mount.

4. Remove any excess undercoating or rust.



5. Using the bushing retainer as a template, mark the holes to drill with a center punch.

6. Remove the retainer and drill the holes with a 3/8" bit.

7. Place the bearing inside the bearing housing, then clamp it to the frame with the bearing retainer and the 5/16" x 1 1/2" SHCS and lock washers.

Front →

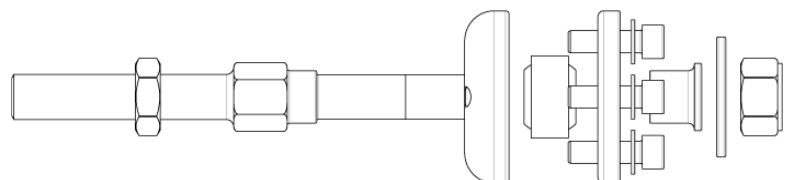





8. The bearing stud should already be threaded into the lower arm, factory set at 2-7/8" (measuring from the end of the arm to the bearing).

9. Slide the stud through the bearing, then slide the aluminum spacer over the stud with the larger end toward the front of the car. Secure the assembly with a 3/4" Nylok Nut and flat washer.

**Note:** The caster setting should be set at around 4.0 degrees positive. Vehicle must be aligned before driving.



10. Install the 2 aluminum spacers into the rod end that goes into the factory control arm pivot.

11. Attach the other end of the lower control arm to the factory frame mount using a 1/2" x 3 1/4" bolt and Hex nut.

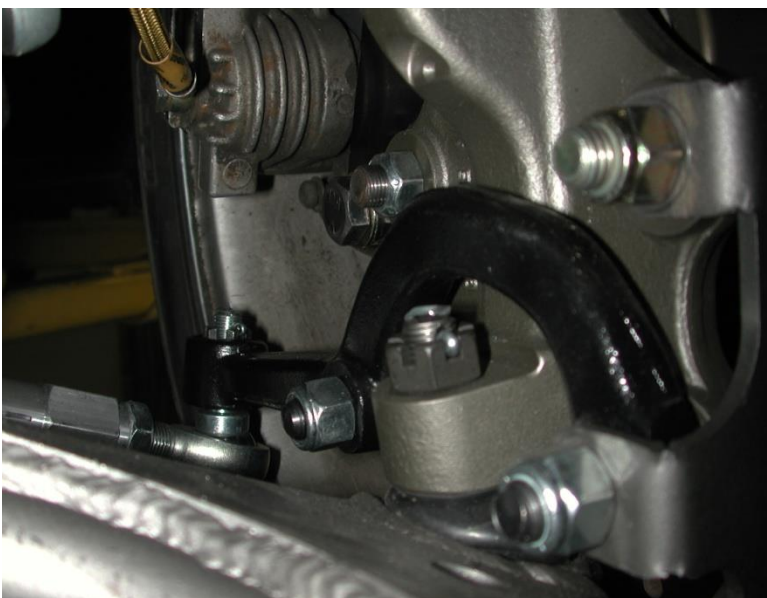

12. Slide the ball joint boot over the ball joint, then place the spindle over the ball joint stud. A ball joint spacer will be necessary to align the castle nut with the cotter pin hole. Grease ball joint

**Note:** Before installing the spindle, turn the ball joint stud so that the cotter pin hole faces front to back. This will make it easier to install/remove the cotter pin.

# STRONG ARMS™

by Air Ride Technologies

Item #	Description	Qty.
1.	Driver side arm	1
2.	Kevlar lined Heim End	1
3.	Control Arm pivot bearing	1
4.	Bearing retaining plate	1
5.	Bearing stud (Set to 2- 7/8")	1
6.	Ball Joint	1
7.	Heim end spacer	2
8.	Bearing Housing	1
9.	5/16" Lock washer	3
10.	5/16"-1 1/2" Gr5 bolt	3
11.	Aluminum bearing spacer	1
12.	3/4"-16 Lock nut	1
13.	1/2"-13 x 3 1/4' Gr.5 bolt	1
14.	1/2"-13 Nylok nut	1
15.	3/4" -16 Jam Nut	1
16.	3/4" X 2" Flat washer	1

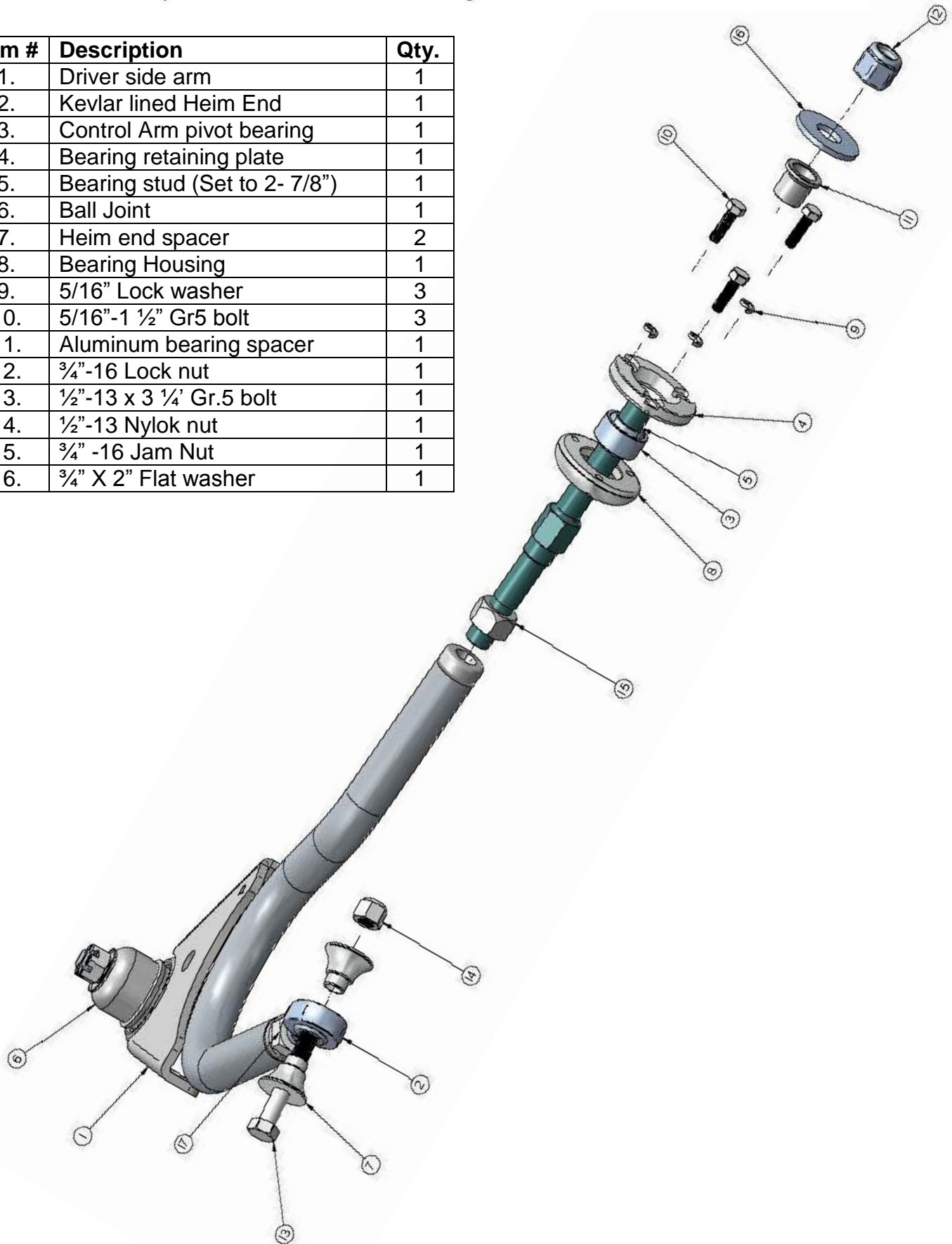

# ridetech

350 S. St. Charles St. Jasper, In. 47546  
 Ph. 812.482.2932 Fax 812.634.6632  
[www.ridetech.com](http://www.ridetech.com)

## Part # 12099500 64 – 66 Mustang TruTurn System



Item #	Part #	Description-Torque Specification	Qty.
1.	90002344	Drag link bracket	1
2.	90001582	LH Thread Heim End	2
3.	99800003	5/8"-18 LH jam nut	2
4.	99800002	5/8"-18 RH jam nut	2
5.	90001590	Heim end	2
6.	90009931	Large stud – tie rod	2
7.	90002351	Inner tie rod stud	2
8.	90002345	Drag link stud	2
9.	90002346	Tie rod adjuster	2
10.	90002347	Driver steering arm	1
10.	90002348	Pass steering arm	1
11.	11009300	RideTech spindle	1 pr.
12.	99502010	1/2"-20 Lock nut-50 ft lbs	2
13.	99432005	7/16"-20 castle nut-35 ft lbs	4
14.	99952002	3/32" Cotter pin	4
15.	99622005	5/8"-18 Thin top lock nut	2
16.	90002349	Driver steering stop	1
16.	90002350	Pass steering stop	1
17.	99502001	1/2"-13 Nylok Nut	2
18.	99501019	1/2"-13 x 1 1/4" Hex Head Bolt	2
19.	99622007	5/8"-18 Mechanical lock nut	4
	99433002	7/16" Flatwasher	6

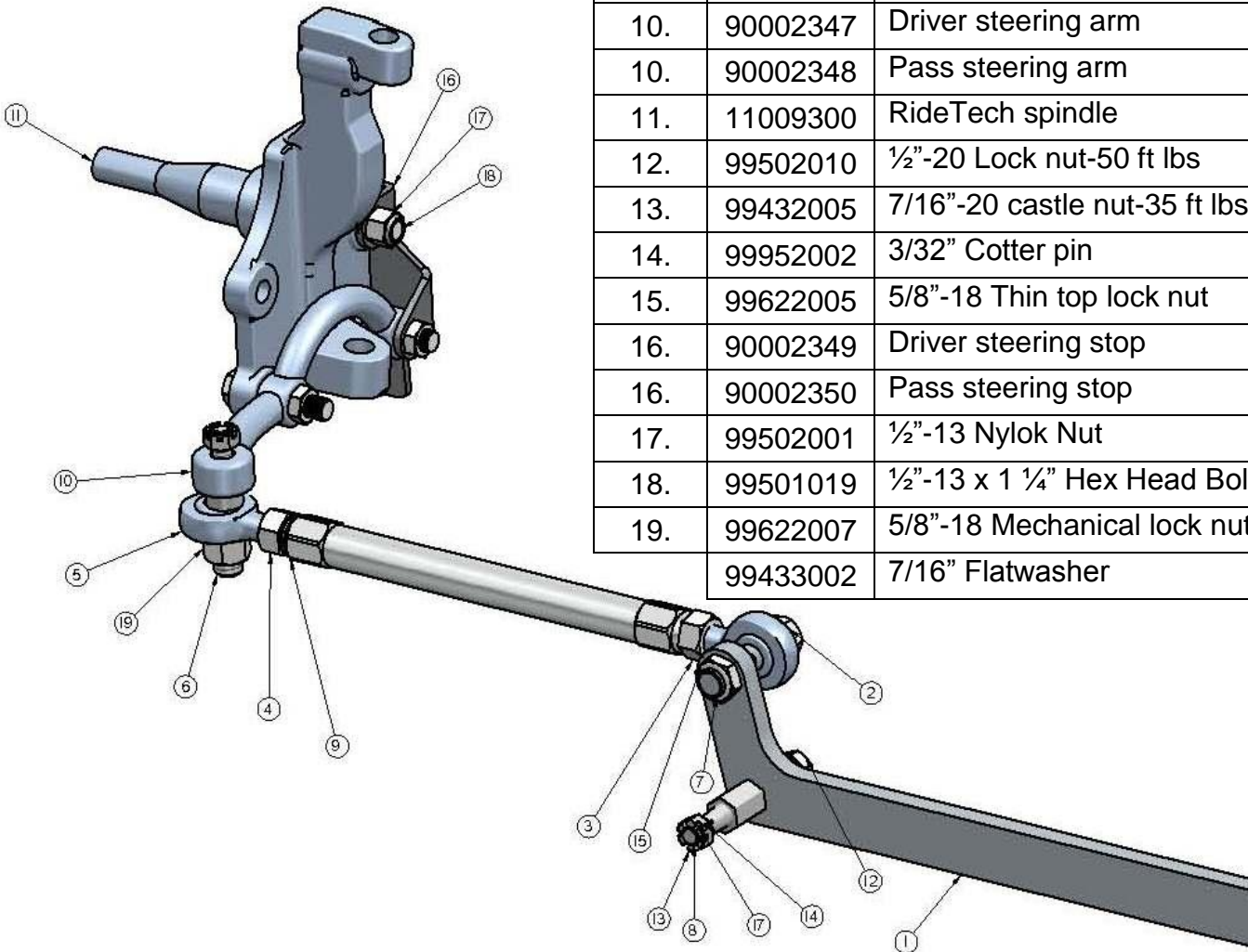



350 S. St. Charles Street Jasper, In. 47546 [www.ridetech.com](http://www.ridetech.com)

## **THIS SYSTEM WILL ONLY WORK WITH RIDETECH STRONG ARMS**

### **Installation instructions**

**This kit can be used with the OEM draglink or Borgeson Power Steering Conversion Kit**

1. You should be using Ridetech Strong Arms and already have installed them.
2. Assemble the new RideTech draglink adapter bracket onto the OEM draglink with the supplied tapered studs and washers per the enclosed drawings.
3. Install the new RideTech spindles onto the control arms per the enclosed drawings. Ball joint nut torque = 83 ft lbs
4. Install the Steering arm and Steering Stop at the same time. The nuts should be on the frame side of the spindle.
5. Install the remainder of the Tru Turn steering linkage as shown in the attached drawings. **MAKE SURE** that ALL cotter pins are used in the appropriate places and that there is no binding or interference throughout the entire suspension travel.
6. Adjust the camber and toe roughly until you can get the vehicle to a proper alignment shop. The recommended alignment settings are:

Camber - -.5 to -1.5 [within .3 from side to side]

Caster – 4 to 7 degrees positive [run .5 degrees more on pass side to allow for road crown]

Toe - 1/8 to 1/4 toe in

Feel free to experiment with alternative alignment settings that may be more appropriate for your particular driving style.

#### Installation notes:

- A. The draglink bracket has one attachment hole [A] that is slotted. This is to accommodate the variations in manufacturing and machining processes, as well as any wear that may have occurred to the original draglink since that time.
- B. RideTech has successfully fitted a Baer disc brake system to this spindle. Other brands of disc brake brackets **MAY** need clearancing or adjustment for proper installation. The RideTech spindle duplicates the GM A body and F body bolt pattern for brake bracket installation. You will need 5 on 4.5" bolt pattern to keep it the same as the factory rear.
- C. **MAKE SURE** that the cotter pins are properly installed in all appropriate places [C] to ensure that the castle nuts do not become loose and fail. These are **VERY** important connections!
- D. IF your oem drag link is severely worn at the inner tie rod attachment holes [D] you may need to replace that unit with a new oem style draglink to ensure that the [RideTech supplied] tapered pin adapters **DO NOT** pull through that hole.



# ridetech

350 S. St. Charles St. Jasper, In. 47546  
Ph. 812.482.2932 Fax 812.634.6632  
[www.ridetech.com](http://www.ridetech.com)

**Note:** Due to variances in the thickness of the factory drag link, 7/16" flat washers are provided and may be needed to align the castle nut with the cotter pin hole.

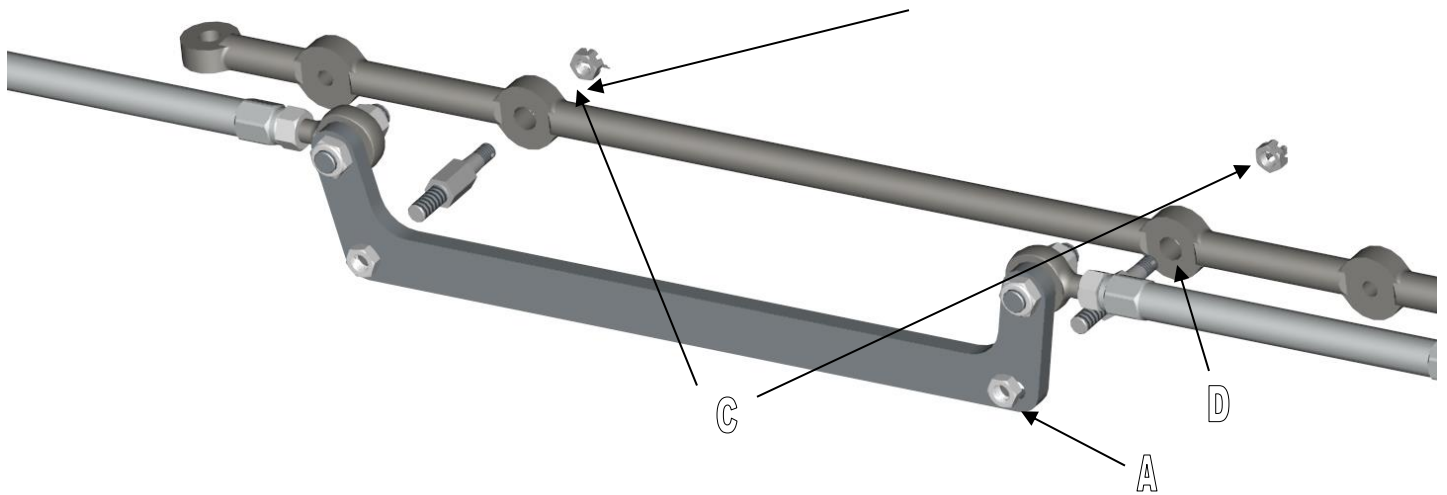

2. The studs with the long hex on them will get installed into the factory draglink with the taper going into the draglink, a 7/16" castle nut is used to attach it to the draglink. Torque the nuts to 35 ft lbs and tighten as needed to align cotter pin hole and install cotter pin. The straight shank will point to the front of the car.

**Note:** It may be necessary to install 7/16" washers under the castle nut to get the cotter pin engaged properly.

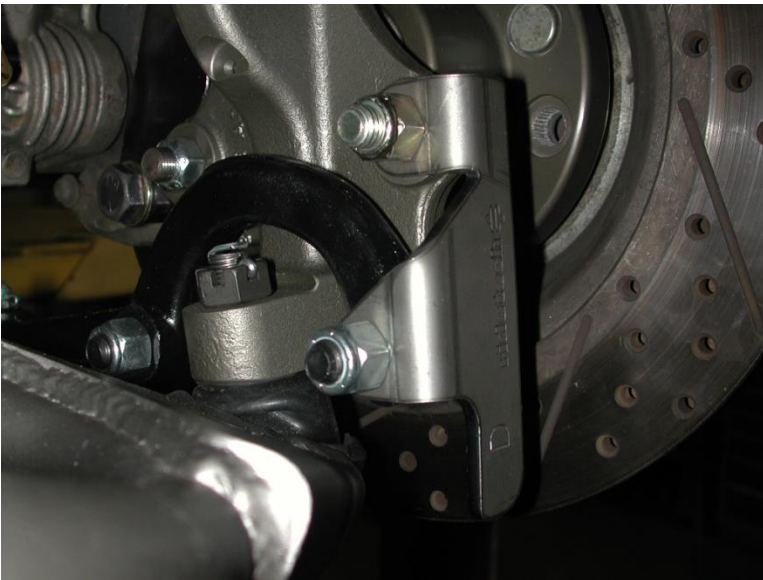

3. Install the Ridetech spindle on the control arms.

4. Install the steering arms and steering stops onto the spindle. The steering arms angles toward the draglink. The steering stops are marked D and P.

The steering arm is attached to the spindle using  $\frac{1}{2}$ "-20 x 2  $\frac{1}{2}$ " Flat Socket Cap Bolts and Nylok nuts.

The upper tab of the steering stop is attached to the spindle using  $\frac{1}{2}$ "-13 x 1  $\frac{1}{4}$ " Hex head bolt and Nylok.



5. Install the stud with the round flange into the steering arm with the taper going into the steering arm. Torque the nuts to 35 ft lbs and tighten as needed to align cotter pin hole and install cotter pin.

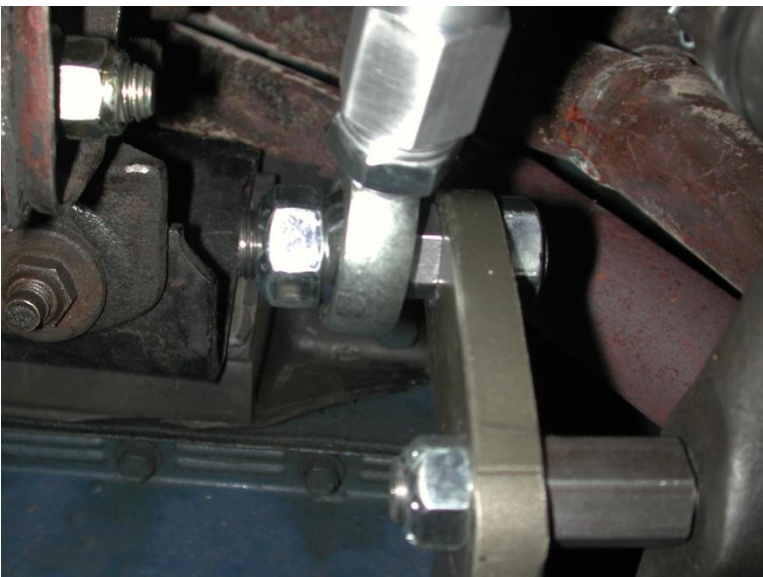

6. The studs with the short hex get installed into the draglink adapter. The short side goes into the adapter attached with the  $\frac{5}{8}$ "-18 thin top lock nut, with the long side of the stud pointing forward.

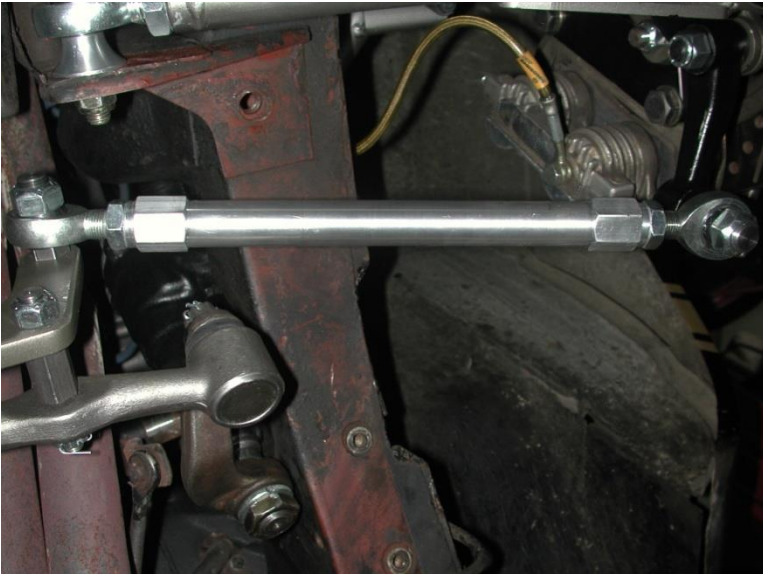

7. The tie rod can now be assembled to a center to center length of 14 1/4" to start with having equal amount of threads on both ends. These Aluminum adjusters have a left hand thread on one end and a right hand thread on the other. You should use antiseize when threading the heim ends into the adjuster.

8. Install the tie rod assembly onto the studs using the 5/8"-18 lock nuts.



**Note:** If using a factory style stamped caliper bracket, the bracket may need to be trimmed. The dust shield may also need to be modified.





350 S. St. Charles St. Jasper, In. 47546  
 Ph. 812.482.2932 Fax 812.634.6632

[www.ridetech.com](http://www.ridetech.com)

## Brake Kits

The Mustang TruTurn Suspension package uses a GM Spindle used on 67-69 F body, 64-72 A body, and 68-74 X body. Any brake kit designed for this spindle will work it just needs a **4 ½" on 5 bolt pattern** to keep the same bolt pattern as the rear of the Mustang.

We had worked with Baer and Wilwood to put together brake kits for our suspension. Both companies have brake kits that will work with your car, depending on wheel size and your braking needs. We have listed the basic brake kit and each company offers options for their brake kits.

### Contact info:

Baer- Phone: 602-233-1411, Web- [www.baer.com](http://www.baer.com)

Wilwood- Phone: 805-388-1188, Web- [www.wilwood.com](http://www.wilwood.com)

### Baer Brake Kits:

Minimum Wheel Size	Baer Part #	Brake Kit Name	Description
15" and bigger (some 14")	4301503	SS4+	4 piston caliper / 11" 2 piece rotor
16" and bigger	4301504	T4	4 piston caliper / 13" 1 piece rotor
	4301505	Pro 13	6 piston caliper / 13" 1 piece rotor
	4301506	Pro+13	6 piston caliper / 13" 2 piece rotor
17" and bigger	4301507	Pro+14	6 piston caliper / 14" 2 piece rotor
	4301508	Ext+14	6 piston caliper / 14" 2 piece rotor
18" and bigger	4301509	Ext+15	6 piston caliper / 15" 2 piece rotor

### Wilwood Brake Kits:

Minimum Wheel Size	Wilwood Part #	Brake Kit Name	Description
14" and bigger	140-1016	Dyna Pro Single	2 piston caliper / 10" 2 piece rotor
15" and bigger	140-10996	Forged Dynalite Pro	4 piston caliper / 11" 2 piece rotor
	140-7675	Forged Dynalite	4 piston caliper / 12.19" 2 piece rotor
	140-10510	Dyna Pro 6	6 piston caliper / 12/19" 2 piece rotor
17" and bigger	140-12271	Forged Narrow Superlite 6R	6 piston caliper / 12.88" 1 piece rotor
	140-9803	Forged Narrow Superlite 6R	6 piston caliper / 12.88" 2 piece rotor
18" and bigger	140-10920	W6A Big Brake	6 piston caliper / 14" 2 piece rotor
	140-9804	Forged Narrow Superlite 6R	6 piston caliper / 14" 2 piece rotor

As with any brake kit you need to check the template to see if it will clear your wheels. These templates can be obtained by going to the brake manufactures web sites listed above.





350 S. St. Charles St. Jasper, In. 47546

Ph. 812.482.2932 Fax 812.634.6632

[www.ridetech.com](http://www.ridetech.com)

**Part # 12099100**  
**64-66 Mustang Front MuscleBar**

- 1 90002343 Sway Bar (Includes the following)
  - 2 Frame bushing
  - 2 Frame bracket
- 2 90002342 PosiLink spacer
- 2 90000103 PosiLink adapter
- 4 90000926 10mm 90 degree PosiLink
- 1 90001092 Tube of lithium grease

**Hardware:**

- |   |          |   |                        |
|---|----------|---|------------------------|
| 4 | 99371003 | 3/8" x 1" USS bolt                        | Frame bracket          |
| 4 | 99372002 | 3/8" USS Nylok nut                        | Frame bracket          |
| 8 | 99373003 | 3/8" SAE flat washer                      | Frame bracket/PosiLink |
| 4 | 99112002 | 10mm x 1.5 Nylok nut                      | PosiLink               |
| 2 | 99115008 | 10mm x 1.5 x 75mm (3") stud (use Loctite) |                        |
| 2 | 99622006 | 5/8"-18 Jam Nylok                         | Posilink adapter       |
| 2 | 99623003 | 5/8" Star washer                          | Posilink adapter       |

**MUSCLEbar™**

# POSI•Link™

## Installation Instructions

\*\*\*\*This sway bar is designed to work with our upper StrongArms\*\*\*\*

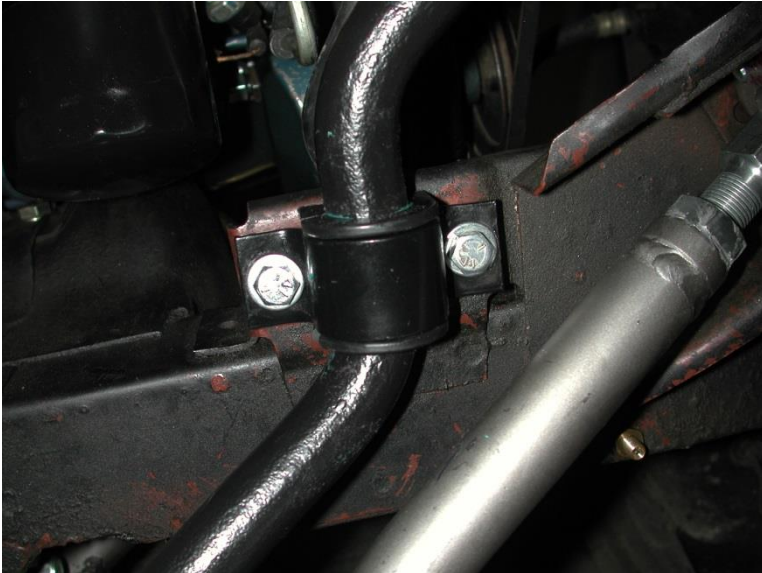

1. Apply lubricant to the poly bushing, then slide it over the sway bar.
2. Place the sway bar frame bracket over the bushing. Bolt the sway bar to the frame using the 3/8" x 1 1/4" bolts, Nylok nut and flat washers supplied.

**Note:** Do not tighten the frame bolts until after the PosiLinks are installed.



3. Attach the 90 degree end of the PosiLink to the front tab of the upper control arm using a 10mm Nylok nut and a 3/8" flat washer on each side of the tab. The nut will be towards the front of the car with the lower nut towards the frame.

Drivers side shown in picture.



4. Install the PosiLink adapter on to the sway bar end. Install the star washer between the adapter and the sway bar with the Nylok on the bottom of the swaybar.

5. Install the Posilink into the adapter with the nut towards the frame of the car.



5. The frame bolts can now be tightened.

6. Check sway bar and PosiLink clearance through full suspension travel.

7. Ensure that the PosiLinks do not bind through full suspension travel.

Pass side control arm shown in picture.







### Part # 12087199 -1965-1970 Mustang Rear Bolt-in 4 Link

#### Recommended Tools

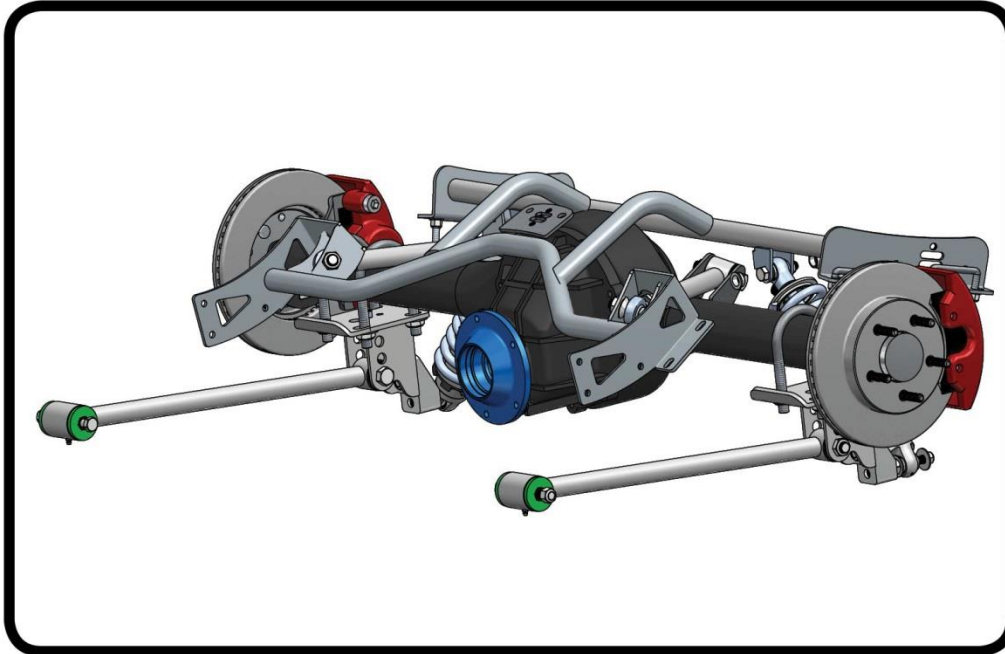

## 1965-1970 Mustang Rear Bolt-in 4 Link Installation Instructions

### Table of contents

- Page 2..... Included components
- Page 3..... Hardware List and Getting Started
- Page 4..... Cradle Installation
- Page 5..... Lower Axle Mount & Lower Bar Installation
- Page 6..... Setting Pinion Angle
- Page 7..... Upper Bar Axle Tab Installation
- Page 8..... Installing Axle Tabs
- Page 9..... Installing ShockWaves/CoilOvers







### Major Components .....In the box

Item #	Part #	Description	QTY
1	90002198	Upper Cradle	1
2	90000615	Lower Axle Mount	2
3	90002843	Lower Bar Assembly - 21 3/4" center to center	2
4	70013767	Front Lower R-Joint Spacer	4
5	90002844	Upper Bar - 11 3/4" center to center	2
6	70013364	RH R-Joint Threaded Housing End (installed in upper bars)	2
7	70011897	Inner Upper Bar Tab - Tall	2
8	70012018	Outer Upper Bar Tab - Short	4
9	90001642	Aluminum Lower Shock Mount	2
10	90001617	Lower Shock Stud	2
11	70013334	R-Joint Spacers	12
12	90002285	Square U-Bolts	7
13	99566001	Axle U-Bolts (+99566002 & 99566003)	4
14	99752004	3/4"-16 Jam Nut (installed on upper bar Heim)	2
	90002067	Lower Shock Spacers	4
	70010694	Bar Tab Setting Jig	2
<b>R-Joint Components - (Installed in bar ends)</b>			
	70013279	Retaining Ring	8
	70013280	Wavo Wave Spring	8
	70013275	R-Joint Center Ball	8
	70013276	R-Joint Composite Center Ball Cage	8

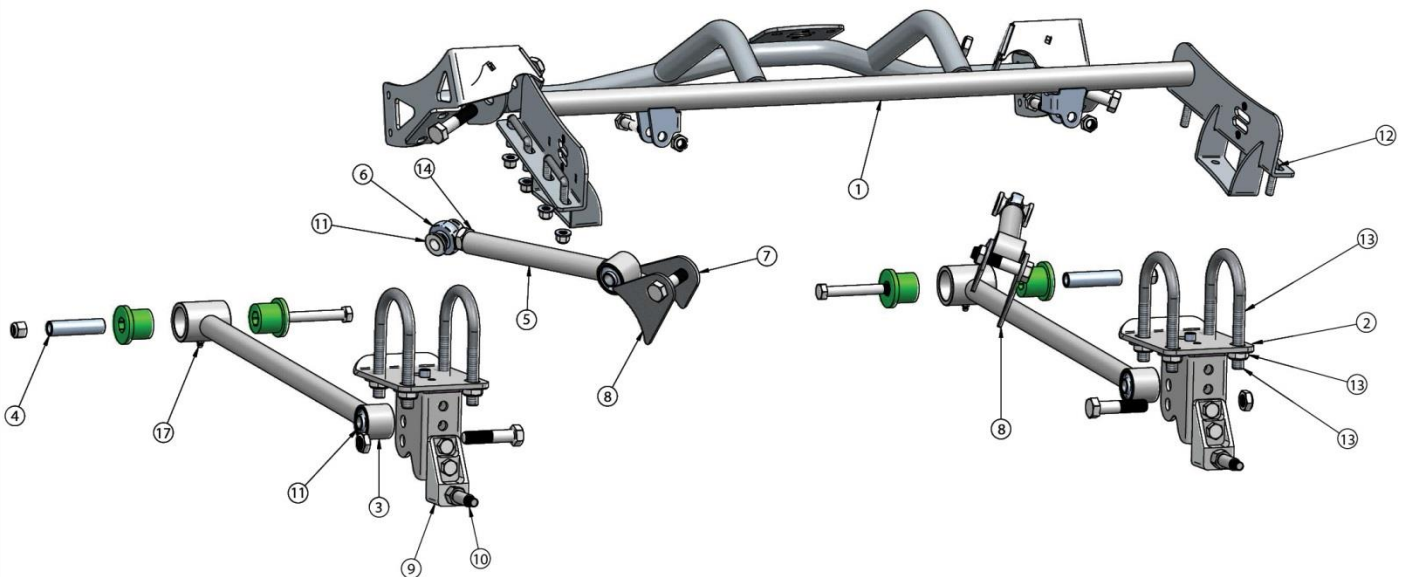



### Hardware List .....In the box (Kit# 99010054)

QTY	Part Number	Description	QTY	Part Number	Description
<b>4-Link Bars to Mounts</b>			<b>Shock to Cradle</b>		
6	99621003	5/8" x 2 3/4" Gr. 8 Bolt	2	99501010	1/2" -20 x 2 1/4" Hex Bolt
6	99622006	5/8" SAE Nylok Jam Nut	2	99502003	1/2" -20 Thin Nylok Jam Nut
<b>Cradle to Car</b>			<b>Front Lower bar to Chassis</b>		
14	99372002	3/8-16" Nylok Nut	2	99501029	1/2" -20 x 6 1/2" Hex Bolt
14	99373003	3/8" SAE Flat washer	2	99501017	1/2" -20 x 4 1/2" Hex Bolt
6	99373007	3/8" -16 Thread Forming Bolts	2	99502002	1/2" -20 Nylok Nut
<b>Shock Mount to Axle Mount</b>			<b>Bar Setting Jig</b>		
2	99501007	1/2" -20 x 1 1/4" Hex Bolt	2	99371001	3/8" -16 x 3/4" Hex Bolt
2	99501009	1/2" -20 x 1 3/4" Hex Bolt	2	99372004	3/8" -16 Hex Nut
4	99502002	1/2" -20 Nylok Nut			

#### R-JOINT SPACER INSTALLATION

Install the Spacers by inserting the SMALL side of the SPACER into the Center Pivot Ball. Push them in until they bottom out and stop.

#### LOWER FRONT R-JOINT

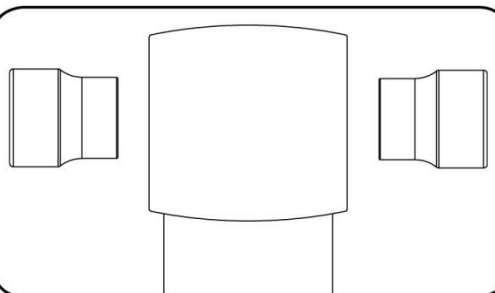

#### ALL OTHER R-JOINTS

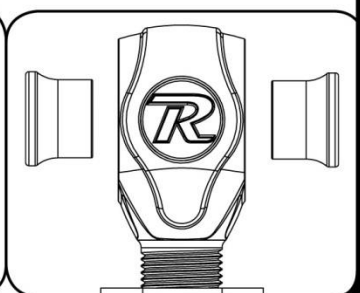

**New R-Joints will be quite stiff (75-90 in/lbs breakaway torque) until they "break in" after a few miles of use. After the break in period they will move much more freely. Because the composite bearing race contains self lubricating ingredients, no additional lubrication is needed or desired. Any additional lubrication will only serve to attract more dirt and debris to the R-Joint and actually shorten its life.**

### Getting Started.....

Congratulations on your purchase of the Ridetech Rear 4-link System. This system has been designed to give your Mustang excellent handling along with a lifetime of enjoyment. Some of the key features of this system: Tune ability, Replaces the Leaf Springs, this allows the 4-Link to locate the rearend and the CoilOvers/ShockWaves to support the car.

**Note:** These system is designed for use with the Ridetech Shockwaves or CoilOvers and the MuscleBar swaybar. **The factory shocks and springs will not fit this setup.**

1. Raise the vehicle to a safe and comfortable working height. Use jack stands to support the vehicle with the suspension hanging freely.
2. Support the axle and remove the leaf springs, shocks and tail pipes. Refer to the factory service manual for proper disassemble procedures. You might have to detach the fuel line form the frame rails.





### Cradle Installation

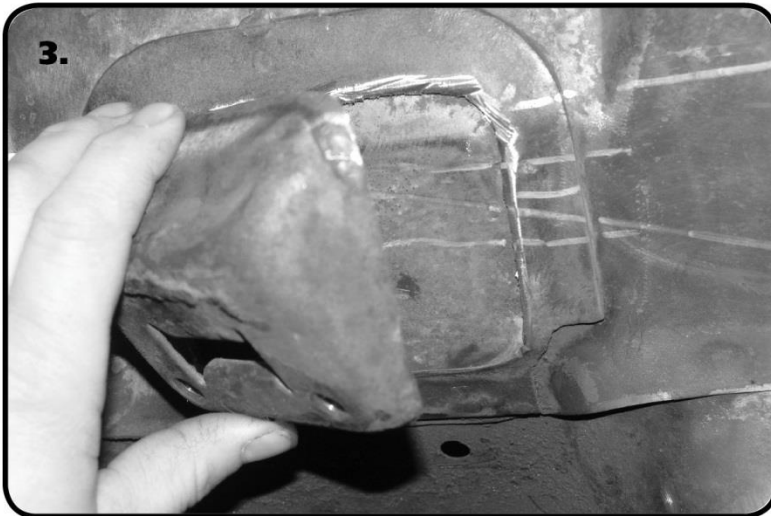

**3.** Remove the Factory Pinion Snubber and Mount from the car. We use a cut off wheel to remove the mount. Notice that we left the mounting lip of the mount attached to the car. This provides another layer of metal for the Front Tab of the Upper Cradle to attach too.

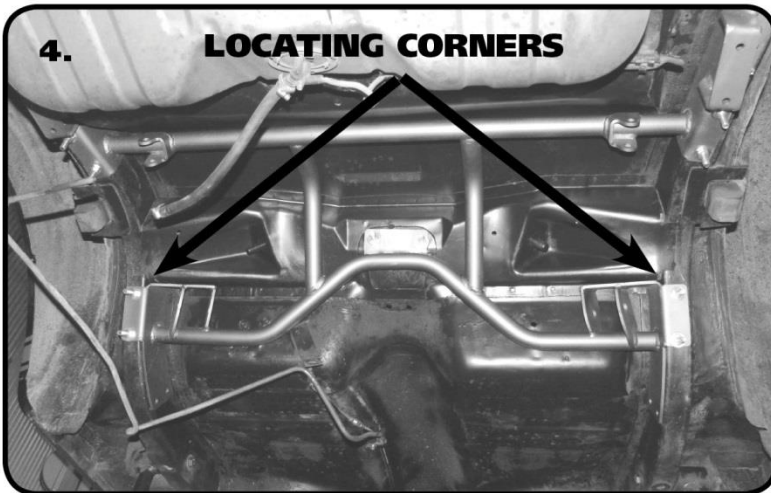

**4.** Install the cradle into the car. The rear corners of the Upper Bar Mounts locate into the front corner of the factory shock sheet metal mount. The Cradle is held in by (7) 3/8" Square U-bolts. Use the Cradle as a locator for drilling the holes. Drill the holes using a 7/16" drill bit. Drill The front 3 holes on each side with a 5/16" drill bit.

**Note:** The OEM fuel line will need to be detached from the frame rails until the Cradle is installed.



**5.** You will notice that the holes are drilled in pairs. Each pair will receive a Square U-bolt. To insert the Square U-bolts into the holes it may be necessary to lower the Cradle to install them. The U-bolts are installed by inserting one end into one of the drilled holes, using the other end as a handle, feed it through the frame until the inserted end will drop down through the remaining hole. Do this for all (7) U-bolts. Install the Cradle into position. Install (1) 3/8" Flat washer and (1) 3/8" Nylok nut onto each stud sticking through the cradle. Do not tighten them until all Washers and Nuts are installed. Install the 3/8" Thread Forming bolts into the 5/16" holes.



### Lower Axle Mount & Lower Bar Installation

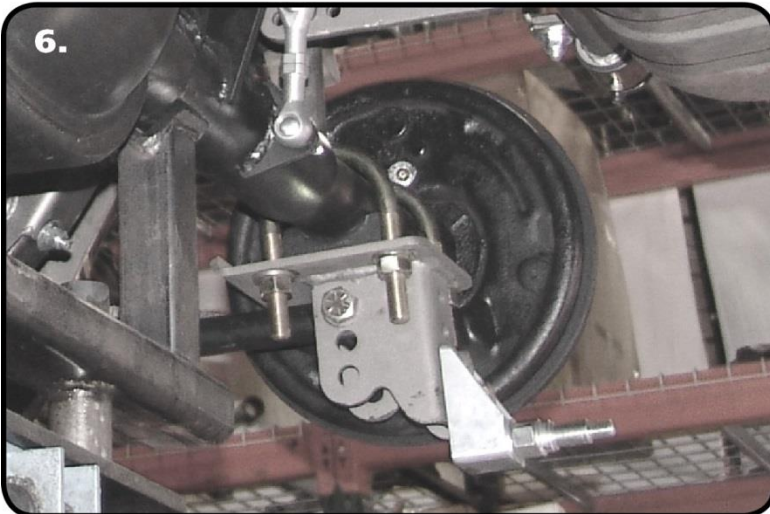

6. Install the Lower Axle Mount onto the Axle using the supplied U-Bolts. Run the nuts down to hold the mount in place, but **DO NOT** tighten yet.

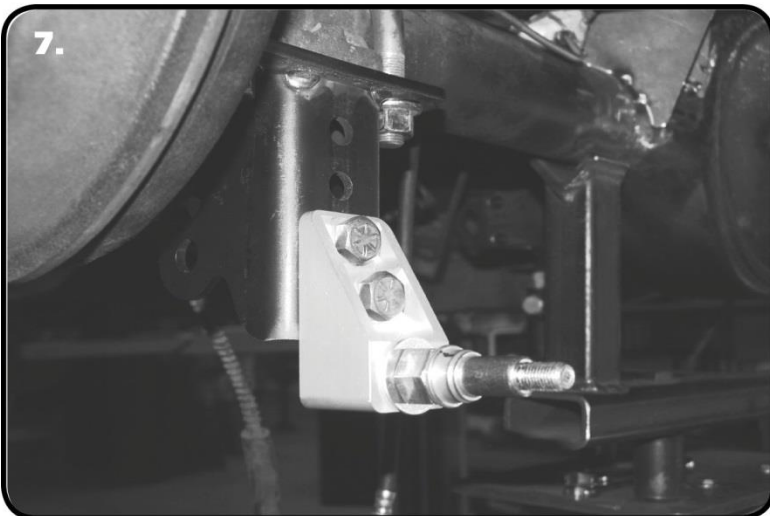

7. Attach the Lower Shock Mount to the Axle Mount using (1) 1/2"-20 x 1 1/4", (1) 1/2"-20 x 1 3/4" Hex Bolts, and (2) 1/2"-20 Nylok Nuts on each mount. The Shock Mount is installed in the **BOTTOM 2** holes of the Axle Mount. Install a Shock Stud and 5/8" washer in each Shock Mount. Tighten the mounting hardware and the Shock Stud.

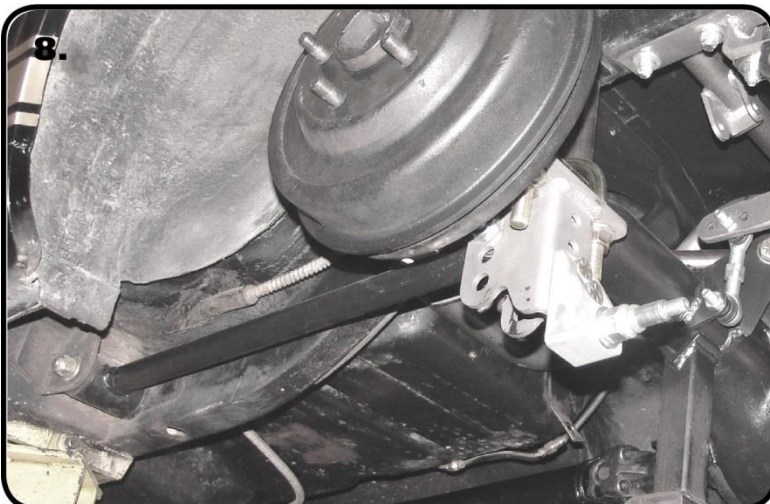

8. Install the Lower Bars. The Front Lower uses the **WIDE**(70013767) R-Joint Spacers inserted into each side of the R-Joint. The Axle end of the bar gets a **NARROW**(70013334) R-Joint Spacer inserted into each side of the R-Joint. The bar is attached to the Axle Mount in the **TOP HOLE** using (1) 5/8" x 2 3/4" Hex Bolt, and (1) 5/8" Thin Nylok Jam Nut. The front of the Lower Bar is attached with 1/2"x 6" Hex Bolt(64-67) or 1/2"x 4 1/2"Hex Bolt(68-70), and (1) 1/2" Nylok Nut.





### Setting Pinion Angle

**READ PAGES 6-8 ON SETTING PINION ANGLES, UPPER BAR TAB JIG INSTALLATION, & SETTING RIDE HEIGHT.**

How do you set the pinion angle? On a single-piece shaft you want to set it up where a line drawn through the center of the engine crankshaft or output shaft of the transmission and a line drawn through the center of the pinion are parallel to each other but not the same line.

Your transmission angle should be around 3 degrees down in the rear. If it is more or less than 3 degrees, you might want to consider changing it. Too little angle on the transmission reduces the amount of oil getting to the rear bushing. Too much transmission angle will increase the working angles of the u-joints which will increase the wear. With the transmission at 3 degrees down in the rear, you will want to set the pinion 3 degrees up in the front.

A simple way to do this is to place a digital angle finder or dial level on the front face of the lower engine pulley or harmonic balancer. This will give you a reading that is 90 degrees to the crank or output shaft unless you have real problems with your balancer. At the other end, you can place the same level or angle finder against the front face of the pinion yoke that is also at 90 degrees to the centerline. If you rotate the yoke up or down so both angles match, you have perfect alignment.

Road testing will tell you if you have it right. If you accelerate and you get or increase a vibration, then the pinion yoke is too HIGH. Rotate it downward in small increments of a degree or two until the problem goes away. If you get or increase a vibration when decelerating, then the pinion yoke is too LOW. Rotate it upward to correct it.

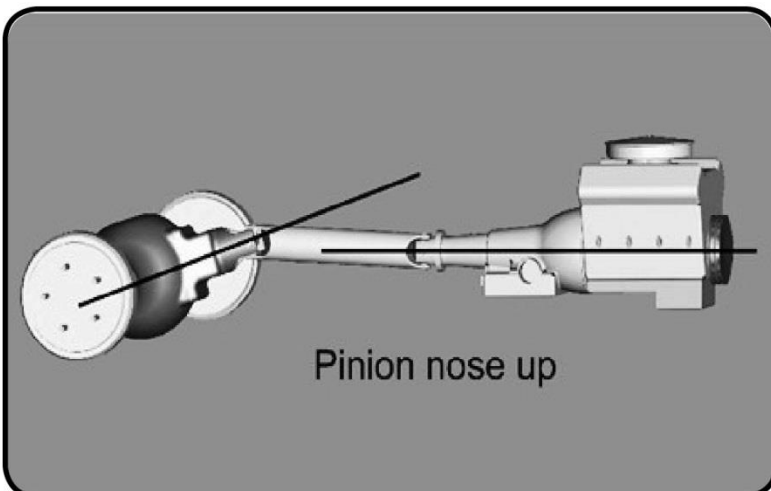
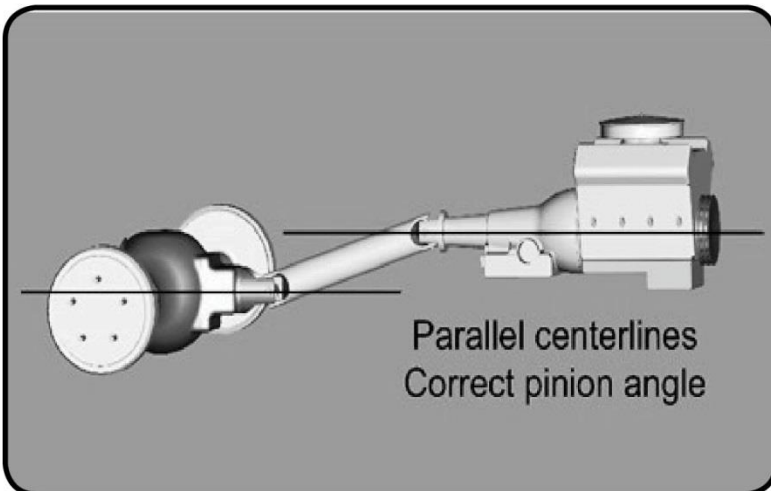
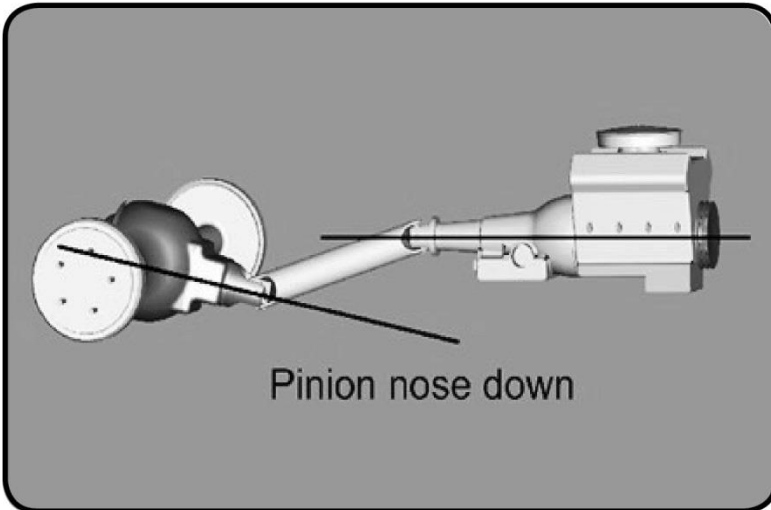



### Upper Bar Tab Installation Jig

#### Upper Bar Installation Jig

- This jig has been supplied to aid in the installation of the upper 4 link bar. It can be temporarily used to properly align, locate and weld the tabs onto the axle. It will also ensure that the mounting bolts are parallel to the ground.
- Follow the diagram below to set the jig to the same length as the upper bar, use the 3/8" x 3/4" bolt and nuts to set the length.
- Position the axle at ride height. Center the axle left to right between the quarter panels. Set pinion angle.
- Bolt one end of the jig to the cradle using a 5/8" x 2 3/4" bolt.
- Using another 5/8" x 2 3/4" bolt, fasten the axle tabs to the other end. The tall tab goes to the outside of the car. The short tab goes to the inside of the car. The tabs must be bolted to the outside of the jig.
- Swing the bar down letting the tabs rest onto the axle. Trim the brackets as necessary to minimize the gap to be welded.
- Check pinion angle, ride height and axle center. Tack-weld the tabs in place.
- Remove jig and install upper bar.
- Repeat this process for the other side.
- Recheck pinion angle, ride height and axle center. (Sound familiar?)
- After the tabs have been tack welded on both sides, remove the upper bars to avoid melting the rubber bushings. Let the axle drop down for better access to the tabs. Lay 1" welds on the inside and outside of the tabs. Skip around from one side to the other to avoid overheating the tube.

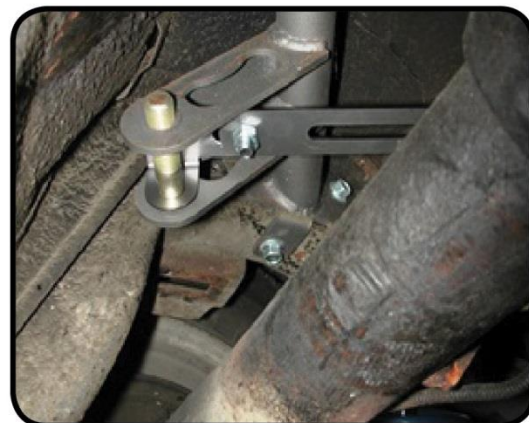
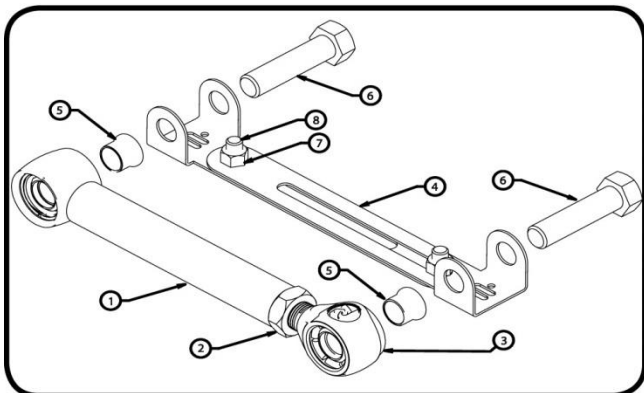

Item#	Description
1	Upper Bar
2	3/4"-16 Jam Nut
3	Heim End
4	Alignment Jig
5	Aluminum Spacer
6	5/8" x 2 3/4" Bolt
7	3/8"-16 Nut
8	3/8"-16 x 3/4" Bolt





### Installing Axle Tabs

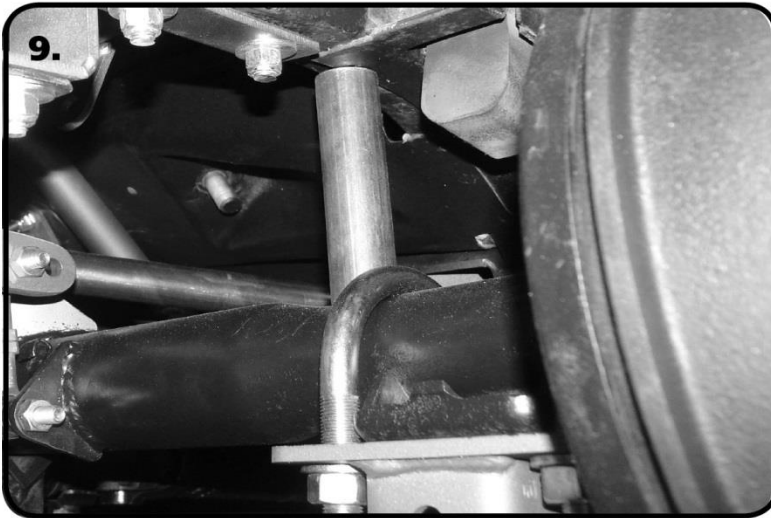

**9.** One helpful trick to maintain ride height when setting the pinion angle is to put a spacer between the axle and the frame. The spacer should be 4 1/2" tall. Set the pinion Angle and axle center. When measuring the axle center you can measure off of the frame rails. We also use a plum bob off the quarter panels to double check the axle center. Refer to Page 6 on Setting the Pinion Angle.

**Note:** You can tack weld the spacer in place after you get the Pinion Angle, and Axle Center set. This will ensure that nothing moves through the Upper Tab Installation.

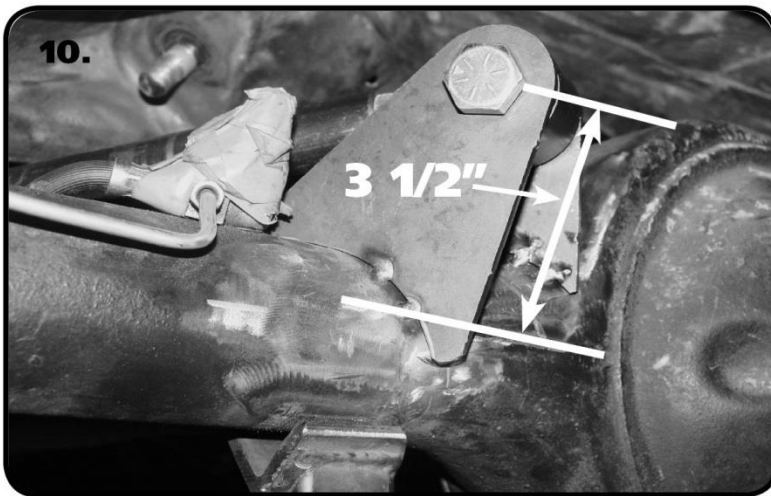

**10.** Refer to Page 7 and set the length of the Upper Bar Jig and install the Tabs on the Jig. Insert the Jig into the Cradle. Set the Upper Tabs on the Rearend. Due to different variations of the Rearend Housings, it may be necessary to modify the tabs for the best fit. The height you are wanting to achieve with the upper bar end is 3 1/2" from the axle center line. Modify the tabs so that the center of the bar bushing will be 3 1/2" from the center of the axle.

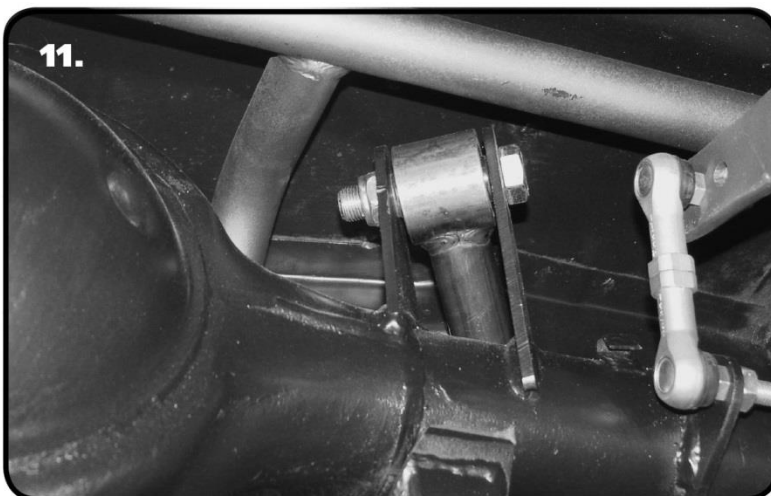

**11.** Once the bar end height is set, tack weld the tabs to the axle. Do this for the Driver and Passenger side bars. Insert the bars into the Cradle and Tabs to double check fitment. Recheck Axle Center and Pinion Angle. Once satisfied with fitment weld the Upper bar Tabs onto the Axle. Weld 1" at a time, skip around from one side to the other, and one tab to the other to avoid overheating the Axle Tube. When the tabs cool down, insert NARROW(70013334) spacers into each side of the R-Joints of the Upper Bar. Attach the upper bars using (1)5/8" x 2 3/4" Bolt, and (1) 5/8" Thin Nylok Nut.





### Installing Shockwaves/Coilovers

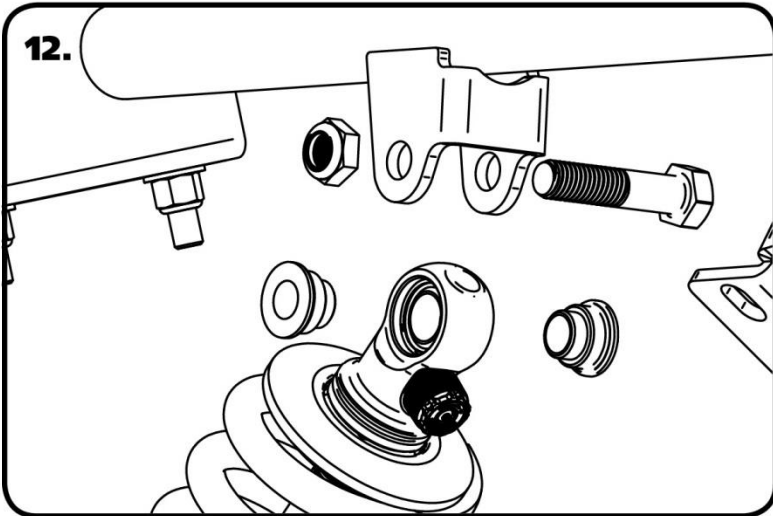

**Remove the Spacer from between the Axle and Frame.**

**12.** Install a 1/2" ID Spacer on each side of the upper Coilover/ShockWave. Slide the assembly into the upper crossmember from the bottom side. If your shock has an adjuster knob position it so that the knob points toward the center of the car. Line up the hole in the spacers with the hole in the upper shock bridge and insert 1/2" x 2 1/2" bolt and install 1/2" Nylok nut.

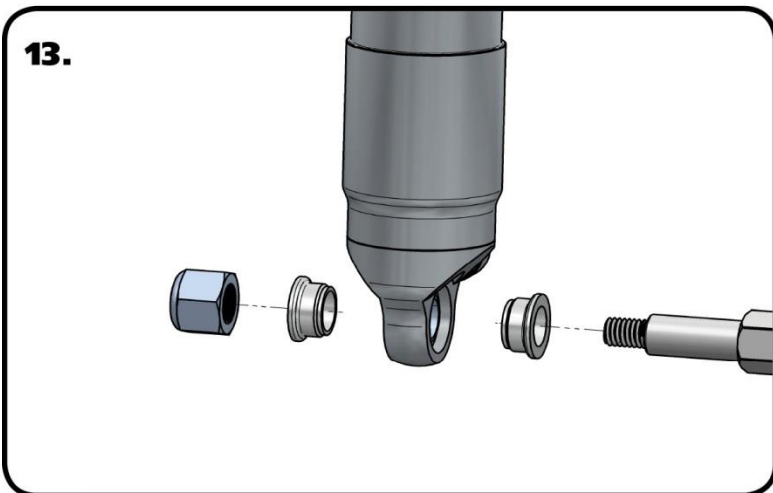

**13.** Install a 5/8" ID spacer( Small side towards shock body) onto the lower Shock Stud. Slide the bottom of the Shock onto the Stud. Install a second 5/8" ID Spacer onto the Stud(small side towards shock). You may need to jack the rearend up to Slide the Shock onto the Stud. Install the 7/16" Flatwasher and 7/16" Nylok nut. Tighten the upper and lower shock bolts.

**Note:** If installing Shockwaves and you want to locate the air fitting in a different location, the air spring assembly can be rotated on the shock by grabbing the shock and air spring assembly by hand and spinning the shock in the air spring assembly.

The designed ride height of the CoilOver/Shockwave is 14 1/2" center to center.

### STILL HAVE QUESTIONS?

#### Tech line hours

Monday - Friday

8AM - 6PM (EST) ..... 812-482-2932



350 S. St. Charles St. Jasper, In. 47546

Ph. 812.482.2932 Fax 812.634.6632

[www.ridetech.com](http://www.ridetech.com)

## Should I weld my AirBar 4 link assembly in?

Since we get this question quite often, it deserves a proper explanation.

The AirBar has been designed for bolt-in installation. We have paid special attention to interfacing with key structural areas of each vehicle, fastening bracketry in at least two planes to properly distribute load paths, and to using appropriate fasteners that roll, rather than cut, threads into the vehicle structure.

Having said that, you could potentially encounter a vehicle that has rust or collision damage in these areas. Or maybe you intend to consistently place the vehicle in severe racing applications with sticky racing slicks and high speed corners. In these cases it is perfectly acceptable to weld the AirBar components into your vehicle. Even in these severe cases we recommend that you install the entire AirBar assembly first [including the fasteners], and then use short 1" long tack welds to secure your installation. Remember that the vehicle structure metal is typically much thinner [.060"-.120" ] than the .188" thick AirBar brackets. If you burn through the vehicle sheet metal structure you may end up with an installation that is weaker than before you tried to weld it.

The other reason to weld in your AirBar assembly is...you simply want to. You're a welding kind of guy...that's the way you've always done it...you have the skills and equipment to do it. In that case...weld away with our blessing!



### Part # 21150701 - 5.2" Stroke HQ Series Shockwave

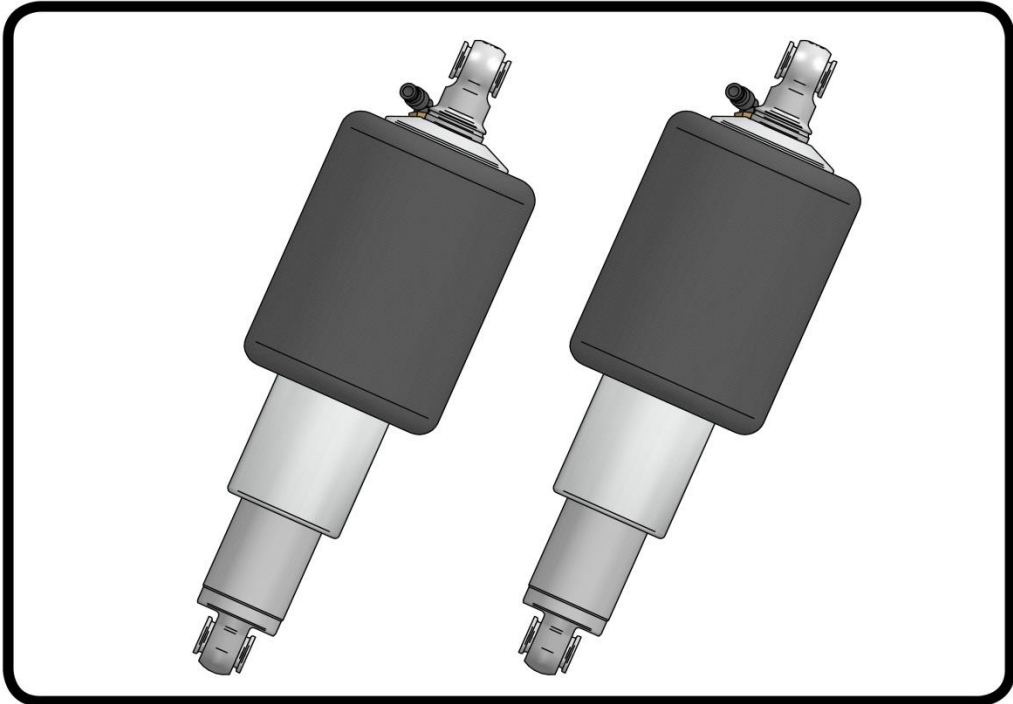

#### Recommended Tools

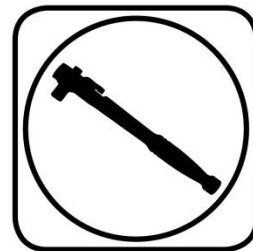

## 7000 Series Bellow, Eye/Eye 5.2" Shock Installation Instructions

Table of contents

Page 2..... Included components

Page 3..... Notes and Care of Your Shockwave

Page 4..... Shock Adjustment

ShockWave Dimensions:

Center of bearing to Center of bearing:	
Compressed:	11.85"
Ride Height:	14.60"
Extended:	16.42"





### Major Components .....In the box

Item #	Part #	Description	QTY
1	24159999	5.2" Stroke HQ Series Shock	2
2	90002024	Shock Eyelet	2
3	24090799	7000 Series, 4" Diameter AirSpring	2
4	70008193	AirSpring Locking Ring (Installed on Shock)	2
5	90002044	Spacer kit - 1/2" ID and 5/8" ID	4
	90001994	5/8" ID Bearing (installed in shock and eyelet)	4
	90001995	Bearing Snap Ring (installed in shock and eyelet)	8

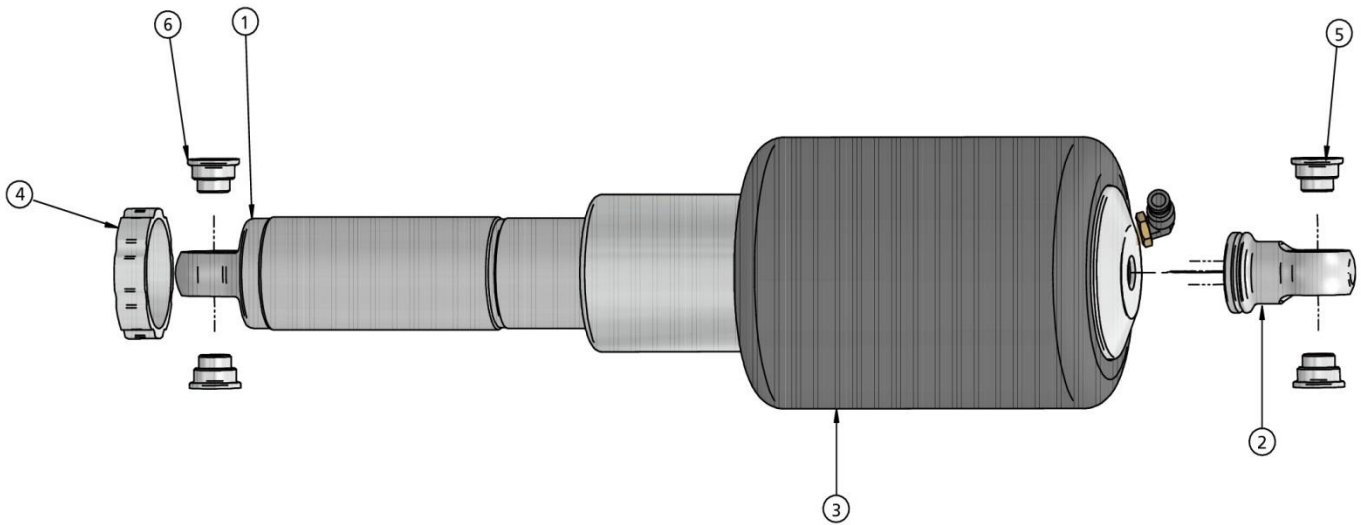

**WARNING: ATTEMPTING TO REMOVE THE AIR FITTING WILL DAMAGE IT AND VOID THE WARRANTY.**