

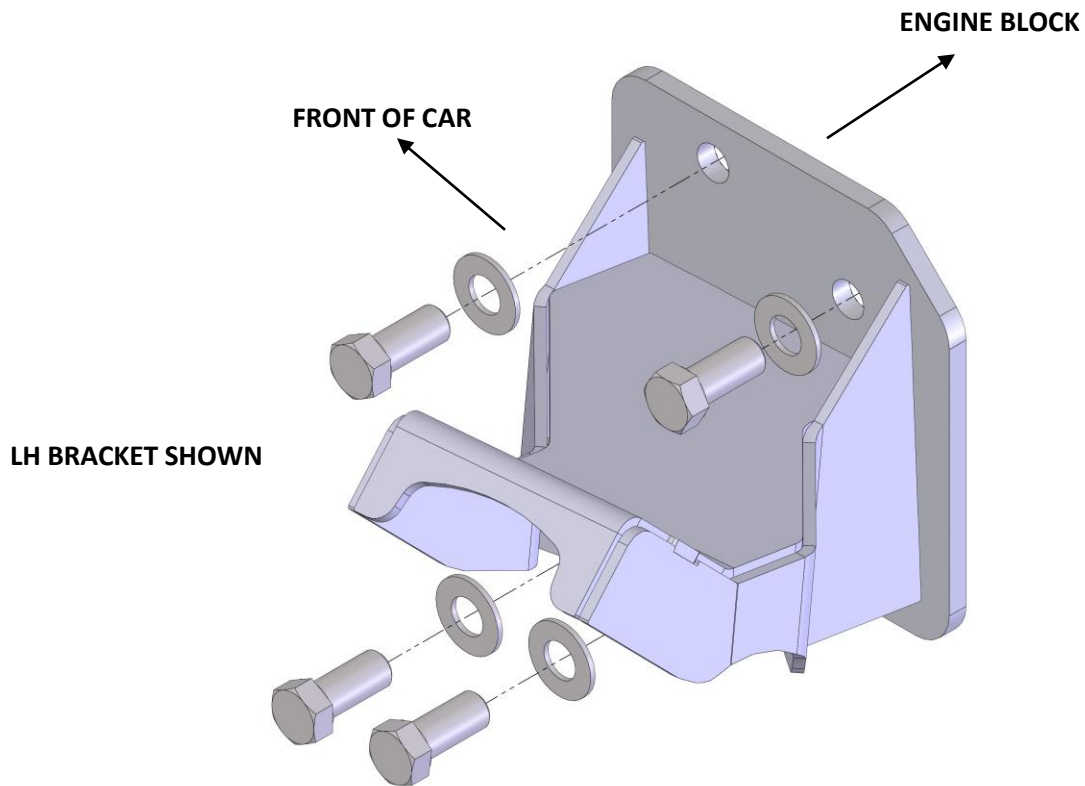

Detroit Speed, Inc.
Ford FE Big Block Motor Mount Kit
DSE 64.5 - 70 Mustang Aluma-Frame
P/N: 060422

The Detroit Speed, Inc. Ford FE Big Block Engine Mount Kit will provide you with an ideal mounting solution for any FE Big Block Engine into a DSE Mustang Aluma-Frame. This kit locates the engine in the stock location. The engine angle should be set at 4 degrees down in the rear. This angle is referenced from the crankshaft centerline.



| Description | Quantity |
|---|----------|
| Engine Mount Bracket, LH | 1 |
| Engine Mount Bracket, RH | 1 |
| 7/16"-14 x 1" Hex Head Bolt | 4 |
| 7/16" SAE Flat Washer | 4 |
| Adjustable Engine Mount Isolator Assembly | 2 |
| 3/8"-16 X 1-1/2" Hex Cap Screw | 4 |
| 3/8" SAE Flat Washer | 4 |
| 3/8"-16 Hex Flange Locknut | 4 |

Using the illustration above for reference, bolt each engine bracket to the engine block using the included hardware. The LH bracket has a cut-out in one of the gussets for steering shaft clearance. Apply medium strength (blue) Loctite to each bolt and torque to 55 ft-lbs. Refer to the Aluma-Frame Adjustable Engine Isolator Kit for their installation.

The Aluma-Frame adjustable engine mount isolators are designed to minimize the transmission and drivetrain vibrations while providing secure mounting for your engine. They are adjustable in 1/4" increments from 1/4" higher than standard height to 1" lower.

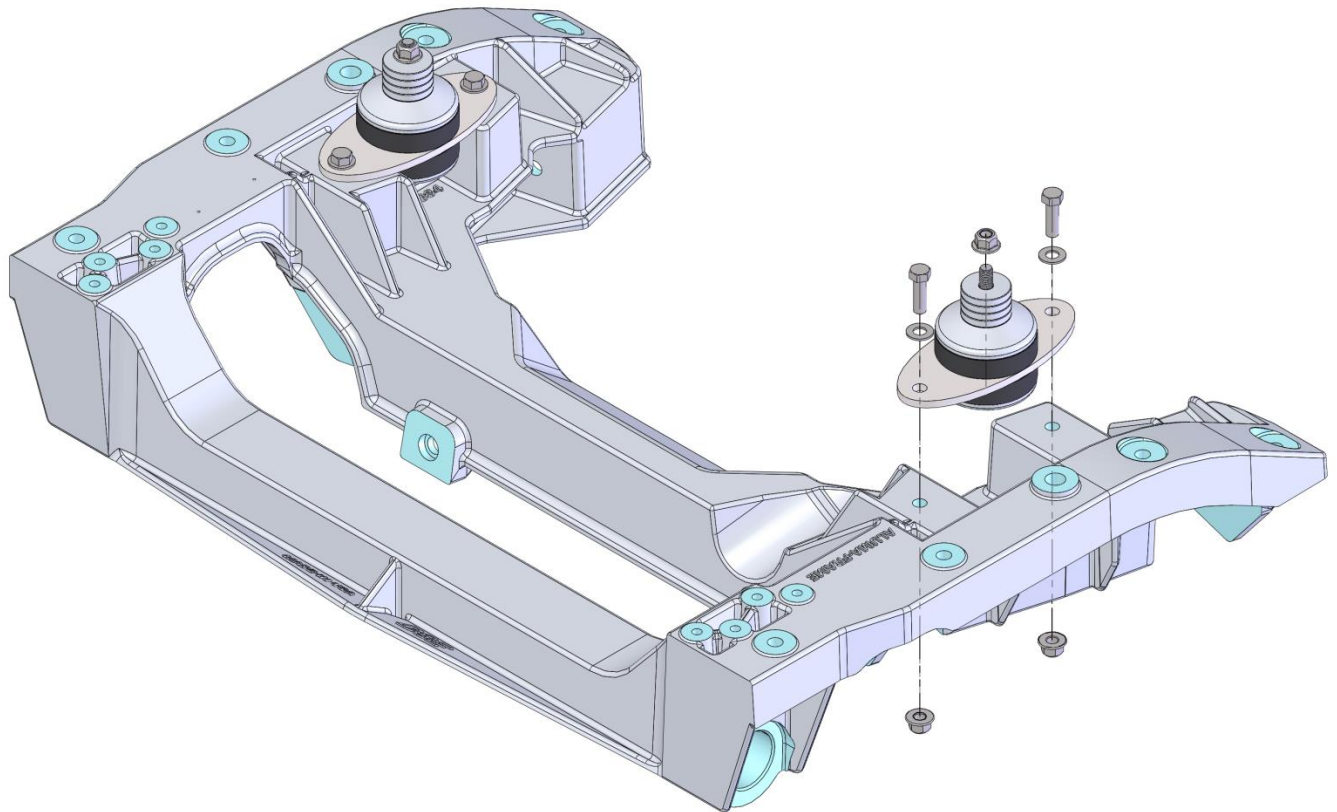

Figure 1

Install the Engine Mount Isolators on the ALUMA-Frame with the provided 3/8" bolts, washers, and locknuts as shown in Figure 1 and torque to 30 ft-lbs. Once the engine is installed, torque the M10 locknuts on the isolator assemblies to 30 ft-lbs.

Engine Mount Adjustment

If the mounts are going to be used in conjunction with a Detroit Speed engine mount kit it is recommended that the isolators remain at the standard height (Figure 2). All Detroit Speed engine mount kits are designed for the engine mount isolators to be installed at the standard height. For some custom installations, the engine mount height can be adjusted if needed.

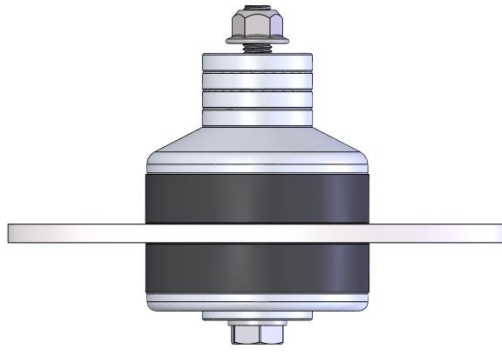

Figure 2: Standard Height-Four spacers on the top and one spacer on the bottom.

To Lower the Engine: In order to lower the engine height, remove the desired number of spacers from the engine mount isolator assemblies (see Figure 3). Each spacer is $\frac{1}{4}$ " tall, so the engine can be lowered up to 1" in $\frac{1}{4}$ " increments.

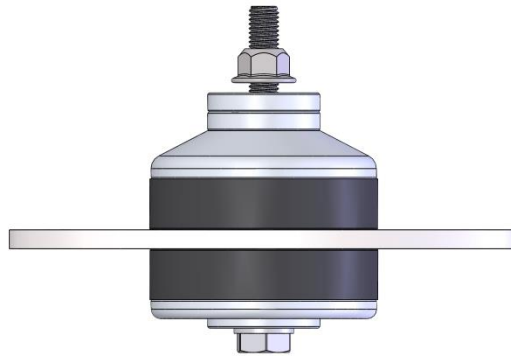

Figure 3: Two top spacer's removed-1/2" lower.

To Raise the Engine: In order to raise the engine, the $\frac{1}{4}$ " spacer at the bottom of the mount needs to be moved to the top resulting in a $\frac{1}{4}$ " increase in height (see Figure 4). Disassemble the mount by holding the top cap with a spanner wrench or other suitable tool and loosen the M10 bolt on the bottom of the mount. Remove the $\frac{1}{4}$ " spacer from the bolt and then reassemble the mount. Torque the bolt to 30 ft-lbs. Add the spacer that was removed from the bottom of the mount to the stack of spacers on the top of the mount.

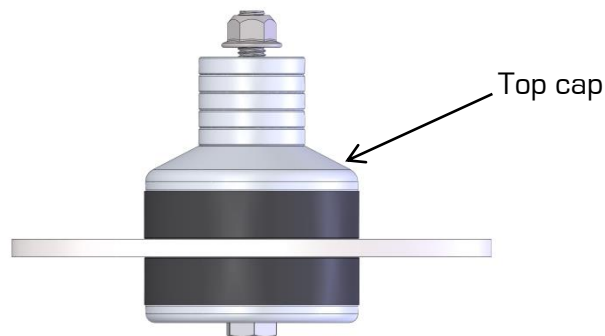

Figure 4: Bottom spacer moved to top-1/4" higher.

Thank you for your purchase. If you have any questions please call Detroit Speed at (704) 662-3272.