



**1964 ½ - 1970 Ford Mustang
Triangulated 4-Link Suspension Installation Instructions**

Tech Line: 1-855-693-1259

www.totalcostinvolved.com

Read and understand these instructions before starting any work!

**USE THE PARTS LIST BELOW TO MAKE SURE YOUR KIT IS COMPLETE BEFORE
INSTALLATION.**

IF ANY PIECES ARE MISSING, PLEASE CONTACT: Total Cost Involved Engineering 855-693-1259



Before



After

NOTE

The following install manual assumes that the factory suspension has already been removed.

NOTE

The following suspension system will not work with heavy duty axle housings as pictured below.





Note: The Mustang wheel well curves outward about 2 inches in the front. This limits the size of the rear tire you can install.



We started by cutting a pie shaped piece out in the seat belt bracket area. Then we slit the wheel well in the center and worked that section inward toward the frame. Keep working it until it is flat like the rear section of the wheel well. We then filled the pie cuts, welded everything up and did a little hammer work. It was a little extra body work but it allowed us to put a 285-40-18 tire on a 9.5 inch wide rim. Looks awesome and the car sits low with a lot of rubber on the ground.



Remove the tabs in the upper corners of floor at the frame rail.



After the tab is removed use a tool of your choice to clear out the excess metal.



Installing the Coilover cross member bracket:
Measure 17.5" from the front face of the rear spring hanger to the bottom of the frame rail and make a mark. The rear edge of the coilover bracket needs to line up with this mark.

We used c-clamp vise grips to hold the bracket in place.

NOTE The coilover bracket is tapered so it will only fit on the frame one direction.



Now that the coilover cross member bracket is in the proper location you may begin drilling up the through the trunk floor.

Using a 5/16" drill bit you will need to drill 4 holes per bracket, 8 holes total.

Here is a picture of the drill bit protruding into the trunk floor.



Once all 8 holes are drilled you may begin installing the provided 5/16" button head hardware. The provided flat rectangle plates are used as reinforcements on the trunk floor. The bolts go in through the top with a washer on top of the rectangle plate. An additional washer goes on before the nylock on the bottom side.

Torque to 29 ft lbs





Now that the first 8 bolts are installed and the bracket is secured vertically it is time to drill through the frame.

Start with the forward most hole using a 3/8 bit. This is the only hole that has access from either side of the frame not requiring the provided Drill Guide(*see 2 steps below).

The picture to the left is showing the hole being drilled from the outside going in. Once you are through the first layer of the frame, stop and proceed to the next step.



Now you can move the drill to the inside of the frame and continue through the other side of the frame rail.

Repeat the process for the driver's side.



There are 2 holes per side remaining. For these you will need the provided Drill guide to get through the frame straight. Use a c-clamp vise grip to hold the drill guide in place on the existing hole of the bracket. Repeat this process for the remaining holes.

NOTE There are 2 different length bolts used at this step.

Rear most bolt = 3/8-24 x 2.75" Go ahead and install the two rear most bolts, nuts & washers for both sides of the vehicle.

The remaining bolts = 3/8-24 x 3" At this time just install the bolts with no hardware. You will want to leave the threaded end of the bolt flush with the edge of the bracket at this time. The cross member installation in the next step will use these two bolts to attach and they need to be out of the way.





Installing the Coilover Cross Member:

NOTE If you bought your kit with the optional anti-sway bar please see page 7 of the manual. If not, proceed below.

The coilover cross member installs with the shock and anti-sway bar brackets towards the back of the vehicle.

Push the coilover cross member up into place. The holes on the crossmember will line up with the two forward most holes on the bracket we just installed.



Once the holes on the frame bracket and cross member line up you can now push the bolts we left loose through the holes on the cross member.

Use the remaining 3/8" washers, nylocks and 4 remaining bolts on the cross member.

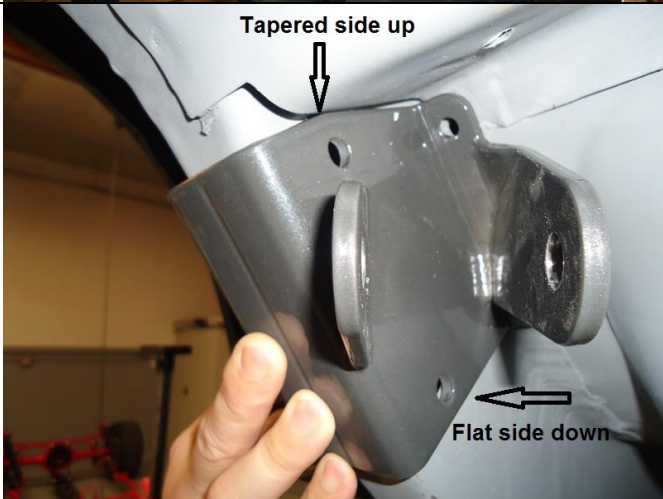

Installing the Triangulated 4-Link brackets:

NOTE You will need to remove the back seat for the following steps.

The brackets have a flat side and a tapered side. The tapered side goes up as shown in the driver side picture shown to the left.

These brackets are also tapered internally to match the thickness of the frame rail. Once you've got the proper bracket, push it up into the pocket of the floor and tight against the rail.



Use a C-clamp vise grip to hold the bracket in place and use a 5/16" bit to drill up into the floor.

passenger side shown

NOTE A long drill bit will make things easier



Continue drilling all holes that go in through the floor.

passenger side shown



Use the provided square plates as reinforcement behind the back seat. Use the provided 5/16" button head bolts with washers under the bolt head and before the nylock.



Torque all 8 of these 5/16" bolts to 29 ft lbs.



Now that the through floor bolts are installed and the brackets are secured you can now drill the 3/8" holes through the frame.

You will not need the drill guide for these holes. Just drill through the first layer of the rail from each side.



Move the drill to the inside of the frame to finish off the holes.



The top bolt is 3/8-24 x 2.75

The bottom bolt is 3/8-24 x 2.5

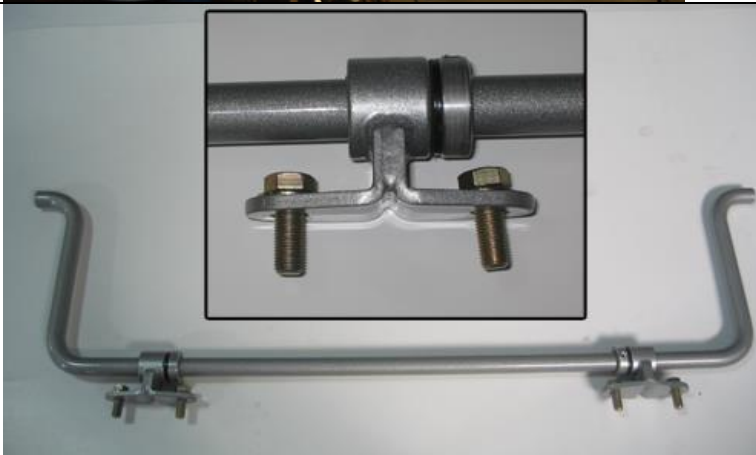

Optional Anti-Sway bar installation

Slide the two aluminum lock rings onto the center of the sway bar. Place the four 3/8" x 1" bolts into the brackets as shown. Slide the brackets onto the bar. Spread the split urethane bushing over the sway bar between the bracket and the lock ring with the flange facing inward toward the lock ring. Using WD-40, slide the bushing into the bracket using the lock ring to assist the install. Don't tighten the lock ring until the sway bar is installed on the cross-member.



NOTE Even though the picture to the left shows the anti-sway bar being installed with rear axle in place already it is much easier to install it beforehand.

Install the anti-sway bar brackets onto the coil-over cross-member brackets that support the anti-sway bar. Install the nuts onto the bracket bolts and tighten. Once the brackets are tightened, the anti-sway bar has to be centered. Rotate the bar up where it is between the frame rails and measure from the end of the bar to the inside of the frame and slide the bar either way until that measurement is equal. Slide the lock rings tight against the flange on the urethane and tighten set screw.

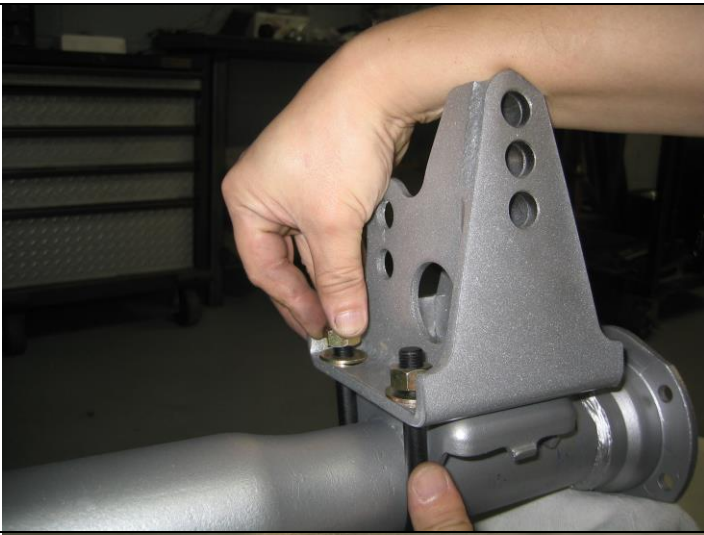

***Installing coil-over axle brackets onto an 8" housing** Bolt the coil-over axle bracket to the leaf spring pad checking that the center hole on the bracket aligns with the center of the leaf pad. If you have a different diameter center pin, use the pin from your old leaf springs. Leave the nuts finger tight at this time.

Note: Most of the 8 inch housings have 2.275" diameter axle tubes but there are some that are 2.75" diameter at the spring pad. The bracket mounts the same on either but they do need different size u-bolts.

Note: If you are using a 9" housing skip forward four steps.



Clamp a flat bar onto the back of both axle brackets to correctly square them to the housing. Once square you can tighten down the u-bolts.

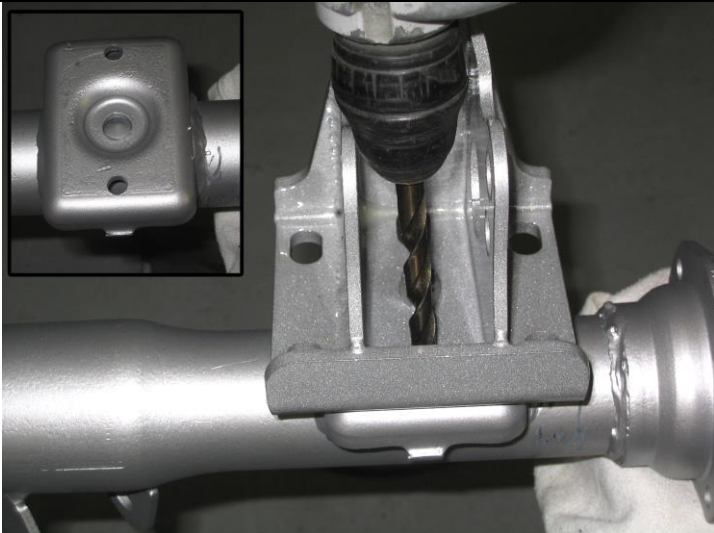

For the 2.275" axle housings, drill a 3/8 inch hole through the spring pad using the hole in the axle bracket as a guide. Repeat the process for the other side.

Note: If you have the 2.75" O/D housing access to the nuts on the inside of the pad is an issue. The front and rear of the spring pad needs to be welded to the axle bracket to prevent the brackets from moving.

After both sides are drilled install the provided allen bolts and tighten.

Note: Shown with the u-bolts removed for a clearer picture.



Here is what the axle bracket will look like once the installation is complete.



Welding axle brackets onto a 9" Housing:

NOTE brackets are designed for 3" axle tubes

We prefer that the axle brackets be installed on the tubes before the bearing flanges are installed.

However, if your axle ends are already on the axle the brackets will need to be cut in half to fit over the axle tubes. If this is the case follow the next step.

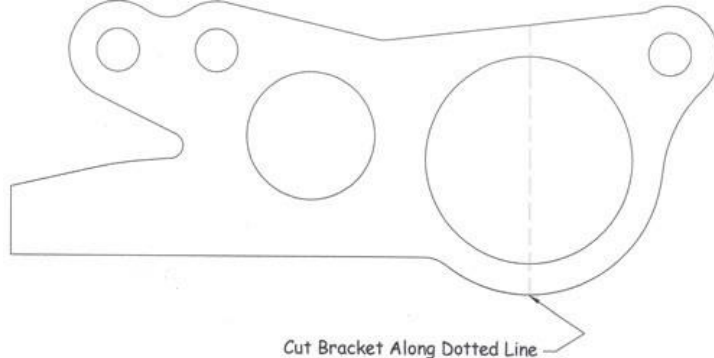

Cut Bracket Along Dotted Line

Use this picture as a template to cut the axle bracket.

Note: The axle bracket shown has an extra hole at the top right which is not used on this application.

Take extra care in realigning and welding them back together. Use the following diagram to install the brackets onto the housing.

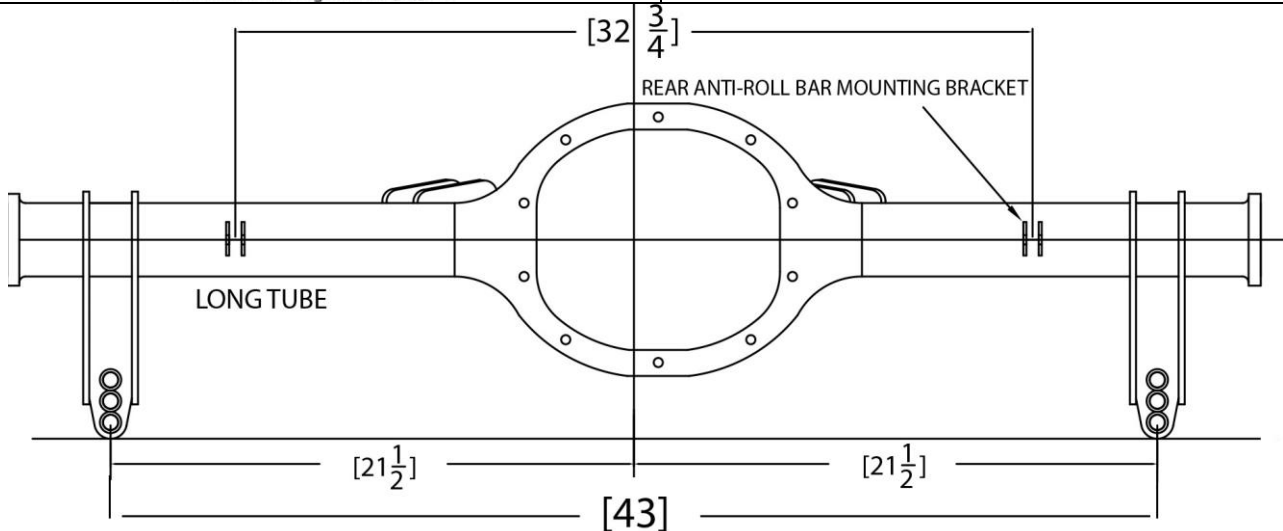

DRIVER SIDE REAR VIEW

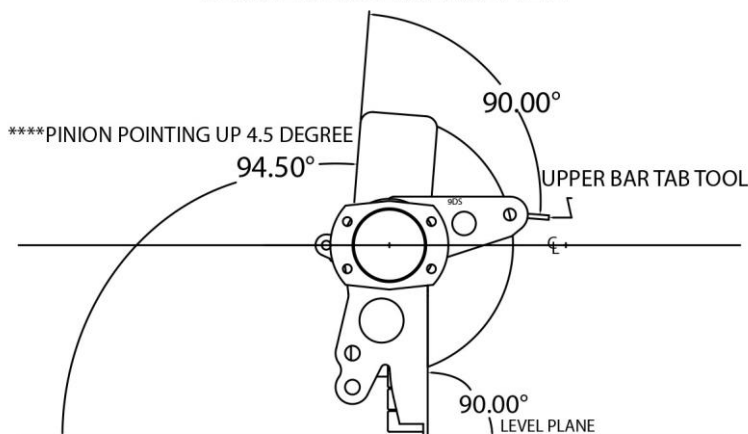

The pinion needs to be pointed up 4.5 degrees as per the picture to the left and at 43" centers per the picture above.

Install the upper link bar brackets onto the fixture tool with the provided hardware. The brackets are labeled left & right. The bolts just need to be snug at this point. Find the centerline of the axle per the drawing below. Reference the centerline of the axle to the centerline line marking on the fixture tool. The flat surface of the fixture tool needs to be 90 degrees from the pinion face per the drawing on the left.

Reference Centerline

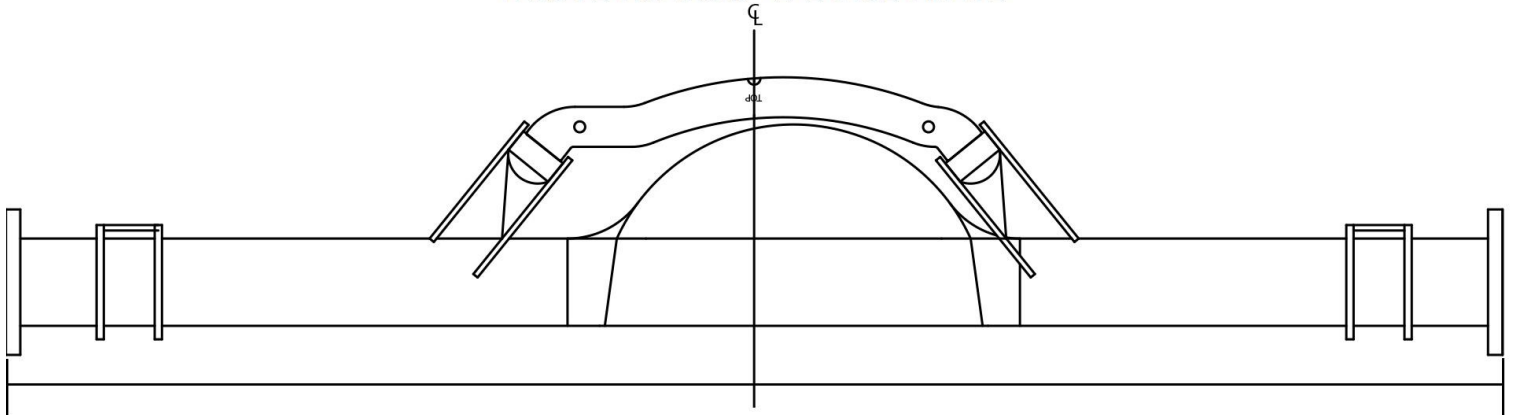

Install the coil-overs onto the lowest hole on the axle bracket using the provided spacer and 5/8" hardware.

Note: The shock pictured has the spring removed for a clearer view of the installation.

Lift the rear axle up into place and install the 1/2" hardware into the upper coil-over mount



Repeat the process for the other side.



The lower bars need to be 21" center to center with an 8" axle (bolt on axle bracket) and 20.75" center to center for a 9" axle (welded on axle brackets).



Lower Link bar installation:

We will be reusing the factory bolt used to hold the front leaf spring in place. There are two different width spacers (3/4" & 9/16") provided in the kit. The wider of the two spacers goes up against the frame. Push the bolt through the frame and into the spacer to hold it in place.



Place one of the link bars with the adjuster side forward into the slot while pushing the bolt in a little farther to keep the bar in place. Now you can install the shorter spacer and push the bolt all the way through.



Install the nut and torque to 85 ft lbs. repeat for the opposite side of the vehicle.



Install the other side of the link bar onto the lowest hole on the axle bracket.

5/8-18 x 3 Bolts with 1/2 nylocks



The upper bars need to be 14" center to center.



Install the adjuster side of the upper link bar onto the frame bracket using the 1/2" hardware.

1/2-20 x 3" hardware with full nylocks



Torque 1/2" hardware to 85 ft lbs

Torque 5/8" hardware to 125 ft lbs

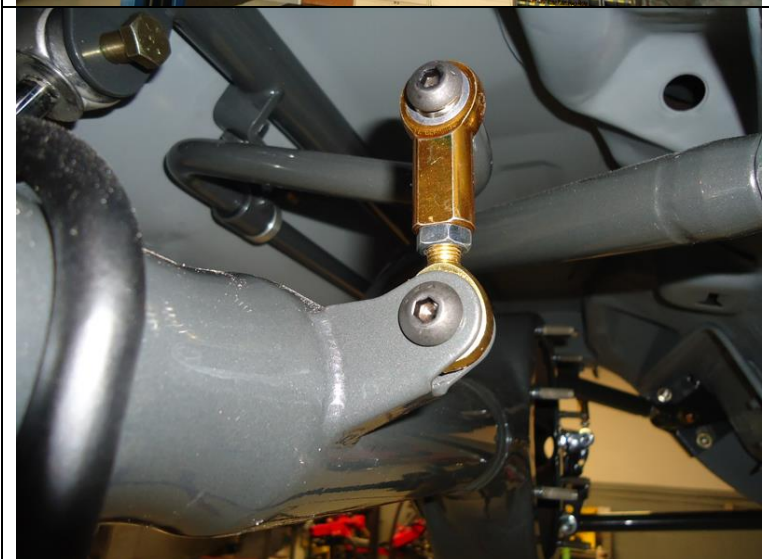

Assemble the heims with jam nut to where roughly 1/4" of threads are showing on the male side. Install the female heim onto the bar itself with the provided hardware. Install the male side onto the axle housing with the provided hardware.

Note: For final adjustment: Disconnect one of the 3/8" anti-sway bar bolts (doesn't matter which one), place the vehicle down on its full weight, with the driver in the driver's seat, adjust the anti-sway bar end link until the 3/8" bolt can be reinstalled with zero preload.

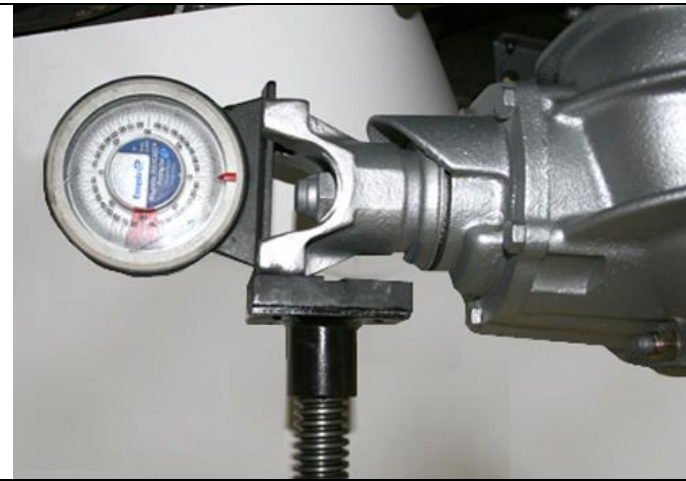

Note: At ride height the pinion angle should be 1 degree up.



Vehicle height can be adjusted by loosening the set screw in the lower shock ring and turning the ring with a spanner wrench. The car needs to be raised up to relieve the weight off the shocks to turn the lower ring.

No returns or exchanges without a RMA#.

Packages must be inspected upon receipt & be reported within 10 days.

If you are missing parts from your kit, TCI Engineering will send the missing parts via FedEx or U.S. mail ground.

Returned packages are subject to inspection before replacement/refund is given. (Some items will be subject to a 15% restocking fee)

Thank you for your business!

