

**American  
Autowire**

www.americanautowire.com 856-933-0801

**500403**

DESCRIPTION:

**Headlight Enhancement  
Relay Kit**

92964990 instruction sheet Rev 3.0 2/1/2015

## Installation Instructions

This kit has been designed to increase the output of your existing headlights. Utilizing relays to supply direct 12 volts to the headlights, this kit eliminates the resistance build up from multiple connection points and smaller gauge wiring. The relays will be activated by your existing lo / hi-beam feed wires from the dimmer switch. The instructions below are for a single headlight system. For a dual headlight system, follow the diagram on sheet 1 to connect extra bulbs. Install kit as follows:

1. Mount relays near front of vehicle (typically on radiator support)
2. Cut existing wires going to driver side headlight (near bulb), and remove any existing wires going to passenger side headlight.
3. Your existing low beam feed wire (tan on GM applications) located on the driver side headlight, will now be cut back to reach RELAY #1.
4. Terminate this low-beam wire with the supplied terminal "A", and plug into relay #1, in the location shown on sheet 1. Install white locking tab "F" in connector.
5. Your existing hi-beam feed wire (It green on GM applications) located on the driver side headlight, will now be cut back to reach RELAY #2.
6. Terminate this hi-beam wire with the supplied terminal "A", and plug into relay #2, in the location shown on sheet 1. Install white locking tab "F" in connector.
7. Route the new light green wire coming from RELAY #2 to the driver side headlight, and cut to length.
8. With the cut off portion of the light green wire, double it together with the light green wire from the relay using the supplied terminal "B", and plug into the headlight connector "D", as shown on sheet 1.
9. Route the free end of the light green wire to the passenger side headlight, terminate using terminal "C", and plug in as shown on sheet 1.
10. Route the tan wire coming from RELAY #1 to the driver side headlight, and cut to length.
11. With the cut off portion of the tan wire, double it together with the tan wire from the relay using the supplied terminal "B", and plug into the headlight connector "D", as shown below.
12. Route the free end of the tan wire to the passenger side headlight, terminate using terminal "C" and plug in as shown sheet 1.
13. Route both black wires from the relays to a good chassis ground, cut to length, and terminate using the supplied ring terminals "E".
14. With the cut off portions of the black wires, terminate using terminal "B" and install in headlight connector "D", as shown on sheet 1. Route the other end to a good chassis ground, and terminate with ring terminal "E".
15. Route the red wire to a 12 volt battery source, protected with a 30A circuit breaker.

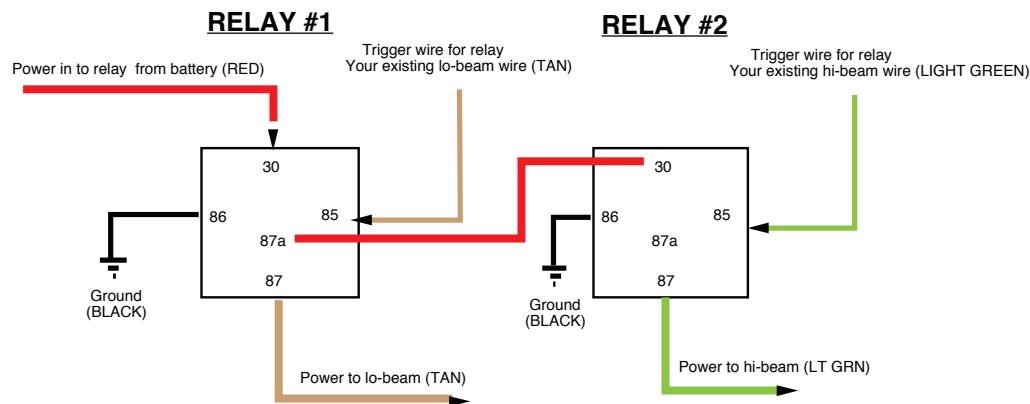

**Relay Schematic**

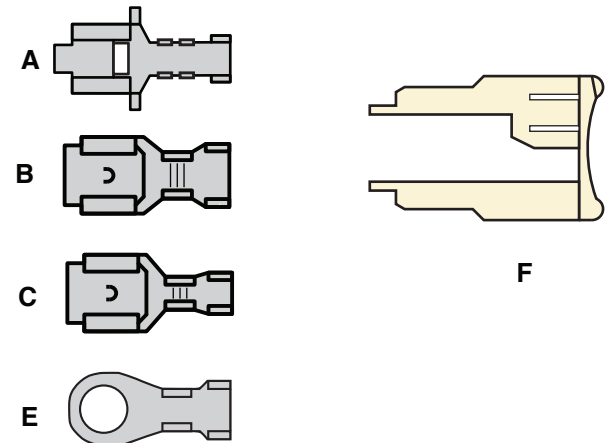

PART #

# 500403

92964990 instruction sheet

Rev 3.0 2/1/2015