



## 1987-1993 Fox Body Mustang Battery Tray Installation

Part Number: E7ZZ-10732-BL

### Parts List

Description	Qty.
Plate	1
Tray	1
Foot	2
Bracket	2
Standoff	2
Hold Down	1
Flat Washer	10
Split-Lock Washer	10
M4 Flat-Head Screw	8
M4 Nylon-Insert Locknut	8
¼-20 x ¾ Button Head Screw	6
¼-20 x 1-1/2 Button Head Screw	4

### Required Tools

- Ratchet
- Socket (7mm)
- 2.5mm Allen Wrench
- 5/32 Allen Wrench

Please verify that all parts are present.

**CAUTION:** If any part of this installation seems beyond your level of installation experience, please seek the help of a certified professional.

### Assembly Procedure

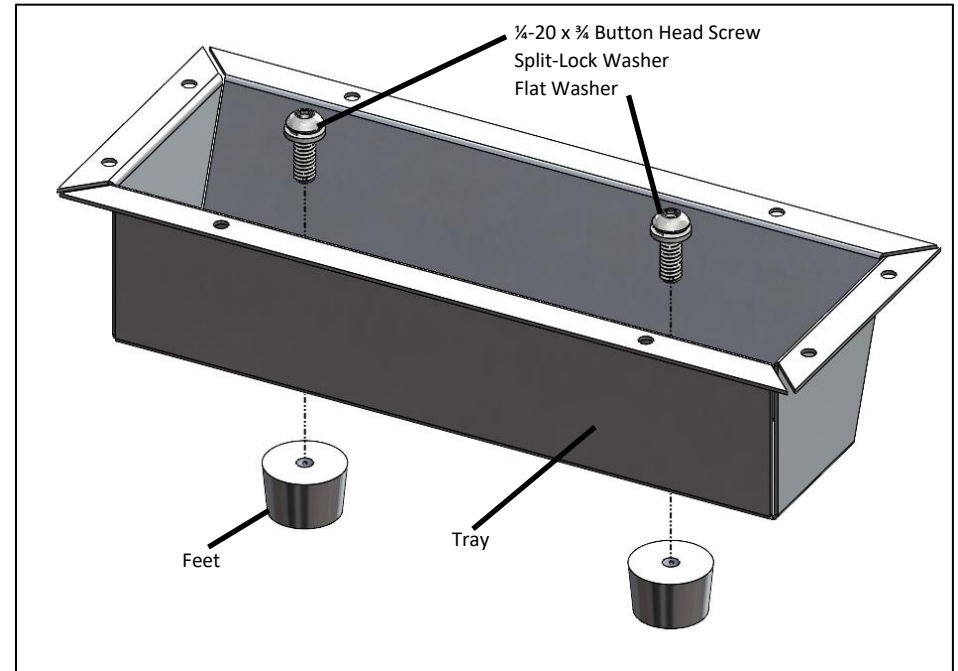

1. Install feet onto tray using two ¼-20 x ¾ button head screws, split-lock washers, and flat washers. Tighten using 5/32 Allen wrench.

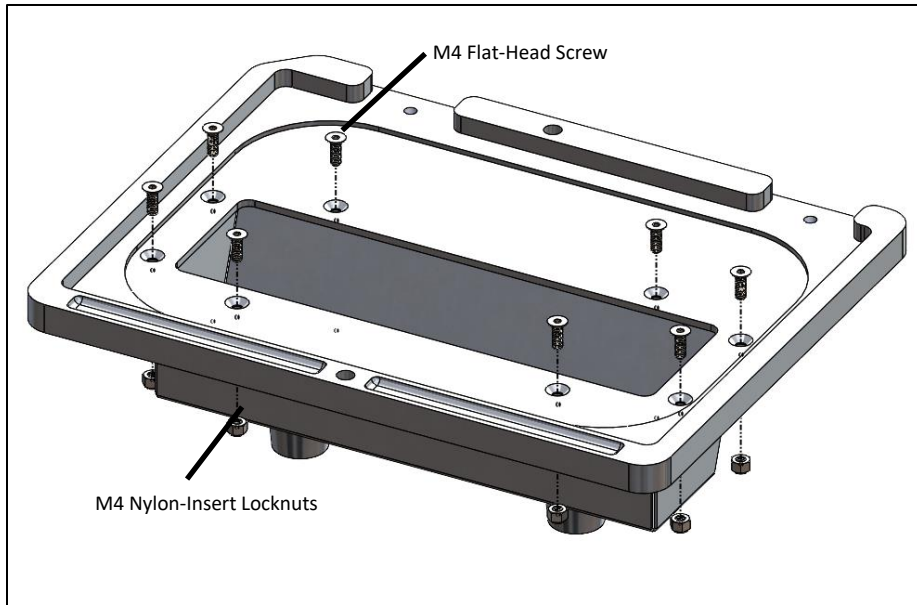

2. Install the plate onto the tray using (x8) M4 flat-head screws, M4 nylon-insert locknuts, 7mm socket, and 2.5mm Allen wrench.

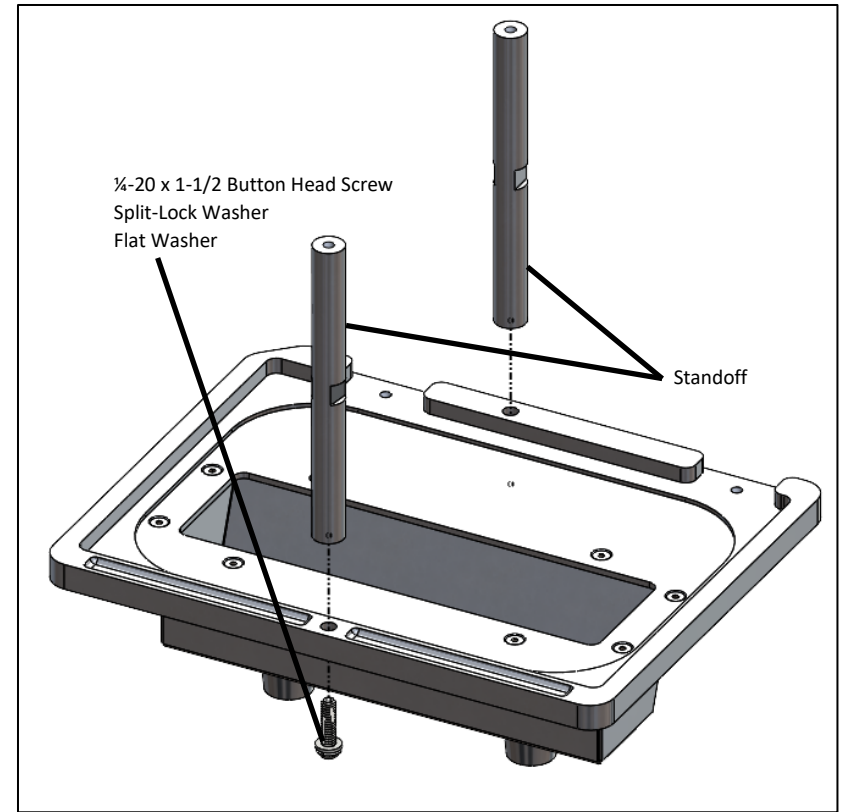

3. Install the two standoffs onto the plate using 1/4-20 x 1-1/2 button head screws, split-lock washers, and flat washers. Tighten using a 5/32 Allen wrench.

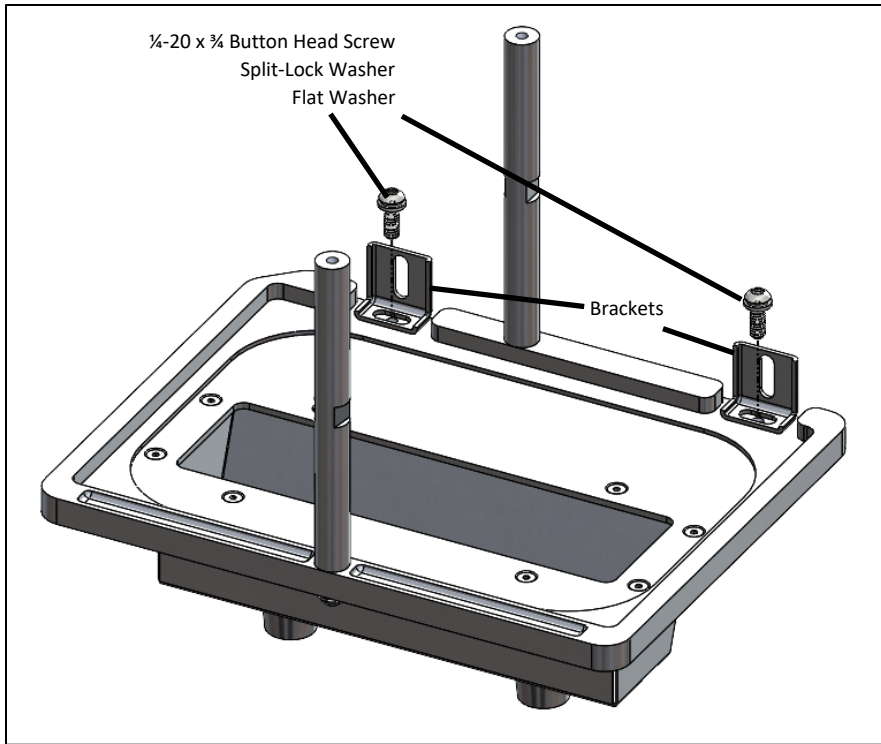

4. Loosely install the two brackets onto the plate using ¼-20 x ¾ button head screws, split-lock washers, and flat washers. Do not tighten completely.

## Installation Procedure

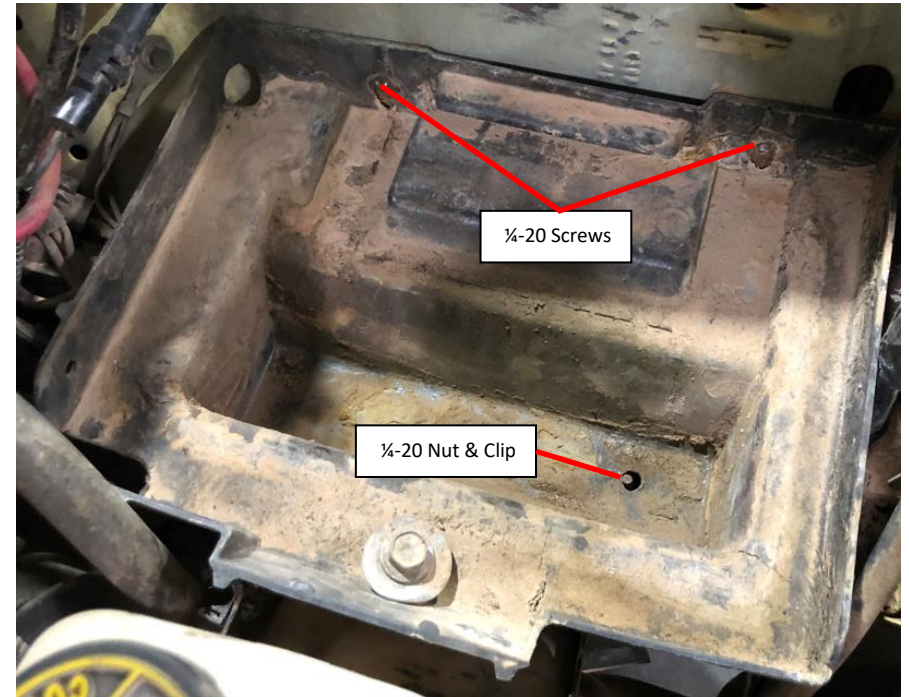

1. Remove factory battery tray from vehicle by removing two factory ¼-20 screws in fender well and one factory ¼-20 nut in bottom of tray. Lift the battery tray out and remove the ¼-20 clip from the frame of the vehicle.



2. Place battery tray assembly into place. Align the two brackets with the factory battery tray holes. Install the two ¼-20 x 3/4 button head screws, split-lock washers, and flat washers. Tighten all four button head screws using the 5/32 Allen wrench (fourth screw not shown).



3. Place battery into tray. Install hold down onto standoffs and complete installation by tightening two ¼-20 x 1-1/2 button head screws, split-lock washers, and flat washers using 5/32 Allen wrench.

Holley® Performance Products, Inc.  
1801 Russellville Road  
Bowling Green, KY 42101

Technical Support: 1-866-464-6553  
Phone: 1-270-781-9741  
[www.holley.com](http://www.holley.com)

© 2022 Holley Performance Products, Inc. All rights reserved. Tous Droits Réservés.