



Part # 12270311 - 2015 up Mustang Level 3 CoilOver System

Recommended Tools

Front Components:

12153111 Front CoilOver Strut Instructions

Rear Components:

12156111 Rear Coilover Instructions

Miscellaneous Components:

85000000 Spanner Wrench

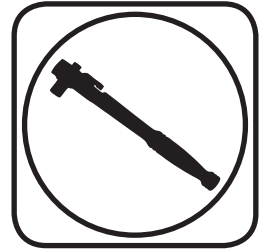

2015 up Mustang Level 3 Coilover Installation Instructions

Table of contents

Pages 2-9..... Front CoilOvers

Pages 10-19..... Rear CoilOvers





Part # 12273111 -2015 up Mustang

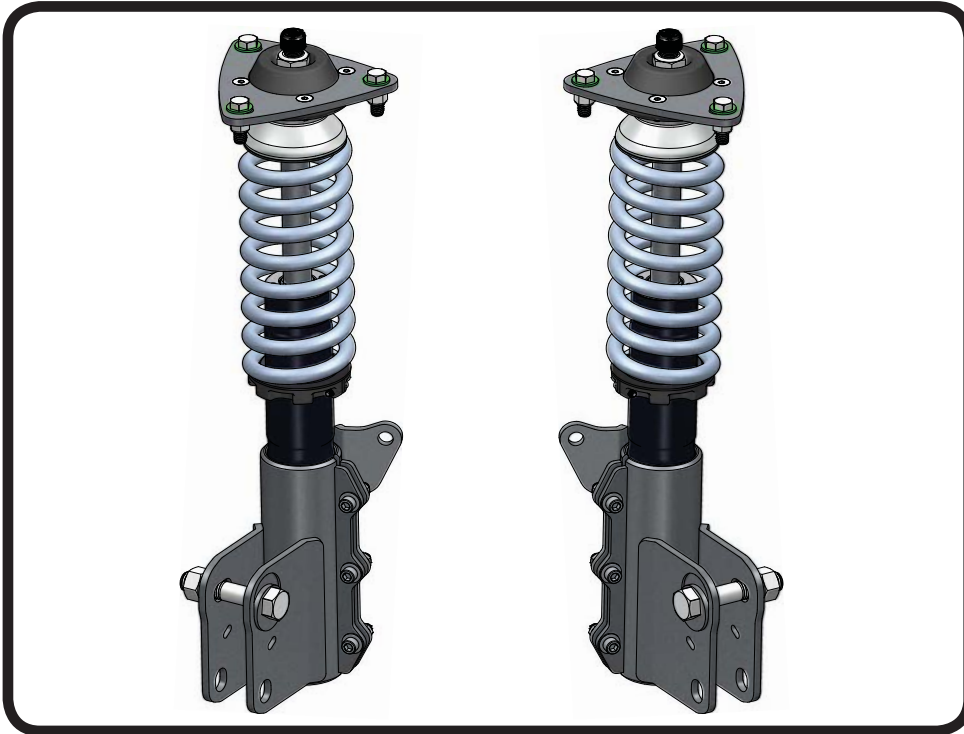

Recommended Tools

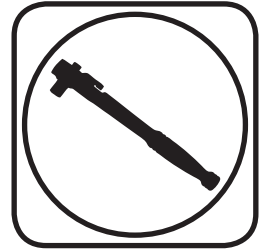

2015 up Mustang Front TQ CoilOver Strut Installation Instructions

Table of contents

- Page 3..... Included components
- Page 4..... Disassembly and Getting Started
- Page 5..... Strut Assembly and Upper Mount Assembly
- Page 6..... Assembly
- Page 7..... Final Assembly and Spring Adjustment and Preload
- Page 8..... Strut Adjustment





Included ComponentsIn the box

Item #	Part #	Description	QTY
1	27669999	Strut Cartridge	2
2	90002540	Bearing Retaining Mount	2
3	90002541	Upper Mounting Plate	2
4	90002542	Lower Strut Mount (Driver)	1
4	90002543	Lower Strut Mount (Passenger)	1
5	90002368	Thrust Bearing Adapter	2
6	70010987	Thrust Bearing	2
7	70010988	Thrust Bearing Washer	4
8	90001042	Upper Mount Bearing	2
9	90000805	Upper Bearing Snap Ring	2
10	99562003	9/16"-18 Nylok Nut	2
11	59080300	8" 300lb CoilSpring	2
12	90002365	CoilSpring to Bearing Adapter	2
13	70010828	Delrin Washer	4
14	90000801	Eccentric Bolt	2
15	70010992	Strut Retaining Ring	2
16	72000008	1/4"-20 x 3/4" Flat SHCS	8
17	99371004	3/8"-16 x 1 1/4" Hex Bolt	6
18	99373003	3/8" Flatwasher	12
19	99372002	3/8'-16 Nylok Nut	6
20	90002070	CoilSpring Cap	2
21	90002222kit	CoilSpring Adjuster Nut	2
22	90002222kit	Adjuster Nut Locking Screw	2
23	99311009	5/16-18 x 1" Socket Head	6
24	99313002	5/16" SAE Flatwasher	12
25	99312003	5/16"-18 Nylok Nut	6
	90002263	Tube of Red Loctite (Not Shown)	1

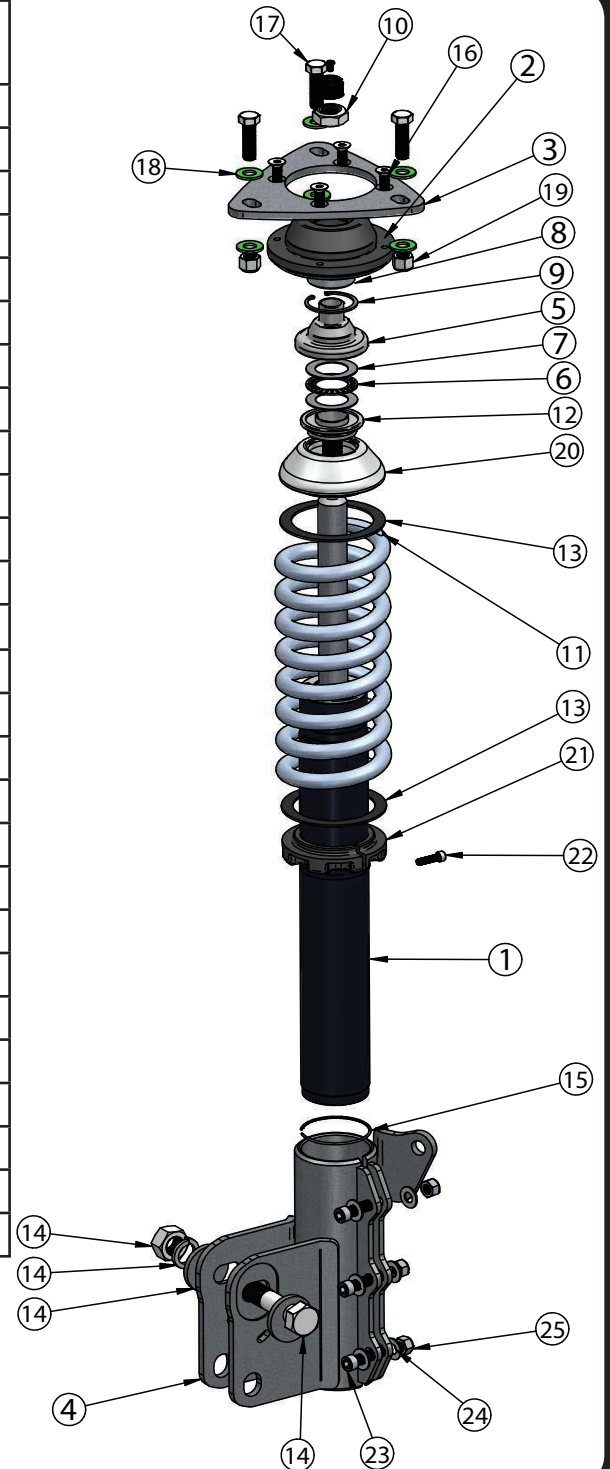



Disassembly

1. Remove the front struts by first disconnecting the ABS wire from the factory strut.
2. Disconnect the swaybar linkage from the strut.
3. Support the front hub and control arm assembly and remove the (2) struts bolts(retain hardware) that attach the strut to the spindle.
4. Remove the (3) nuts holding the upper strut mount to the car body. **DO NOT REMOVE THE CENTER NUT.**
5. Remove strut assembly from the car.

Getting Started

6.

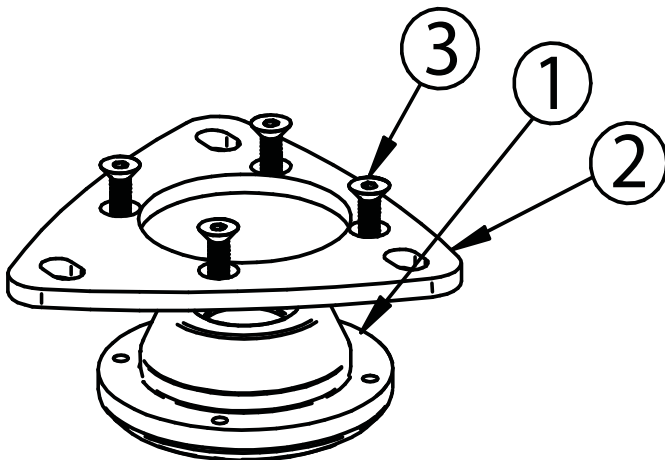

6. The upper will need to be assembled. The plate is positioned with the counter sunk holes up. Insert the Aluminum Bearing Mount into the Plate from the **BOTTOM**. The center of the Aluminum mount will stick up through the plate. Apply Red Loctite to the threads of (4) 1/4"-20 x 3/4" Flat Head Socket Cap Screws. Thread the 4 Caps Screws into the aluminum mount and Torque them to 11ftlbs.

7.

DRIVER SIDE

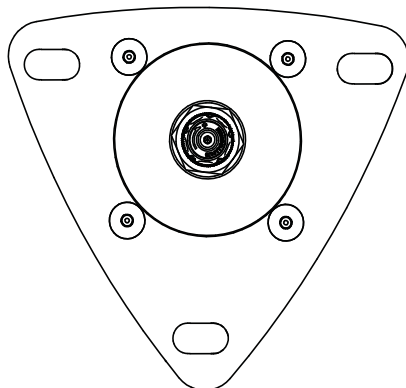

7. The upper strut mount is slotted to provide additional caster adjustment. The upper mount has the top of the strut offset to the inside of the car for tire clearance. It is positioned with the slots running front to rear and strut mount inset toward the engine.



Strut Assembly

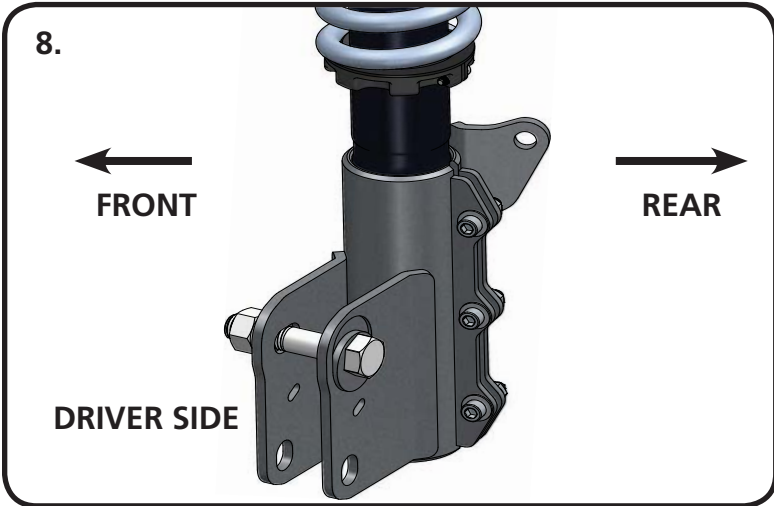

8. There is a Driver and Passenger Strut Assembly. The Sway Bar Tab is to the REAR of the car. The Clamping Bolts will also be positioned to the REAR of the car. Illustration "10" shows the Driver Assembly.

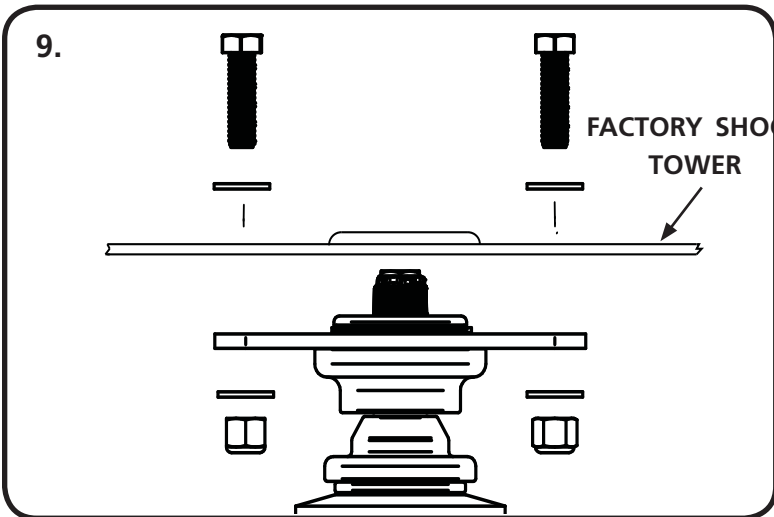

9. Bolt the upper mount into the car, positioning it to the **bottom** side of the Strut Tower. The plate gets bolted in from the **bottom** side of the strut tower using (3) 3/8"-16 x 1 1/4" bolts. Slide the Plate to the FRONT of the Car for an initial setting. Install a 3/8" washer on the top and bottom and secure it with (3) 3/8" 16 Nylok Nuts. Tighten all (3) down.

Note: The camber adjustment will be done on the bottom of the strut using the supplied camber bolt.

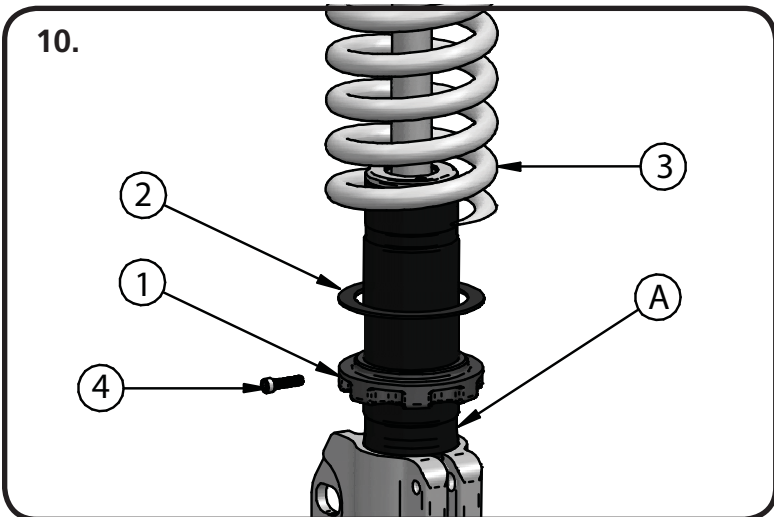

10. The Strut comes preassembled, but if you need to disassemble it, refer to Figure 9 & 10 for assembly order. Install the Coilspring on to the Strut (A) according to Diagram #9.

- 1. CoilSpring Adjuster Nut: thread to bottom of threads for ease of installation of the Strut Assemble.
- 2. Delrin Washer
- 3. CoilSpring
- 4. CoilSpring Adjuster Nut Locking Screw: leave screw loose until final adjustment is completed.



Assembly

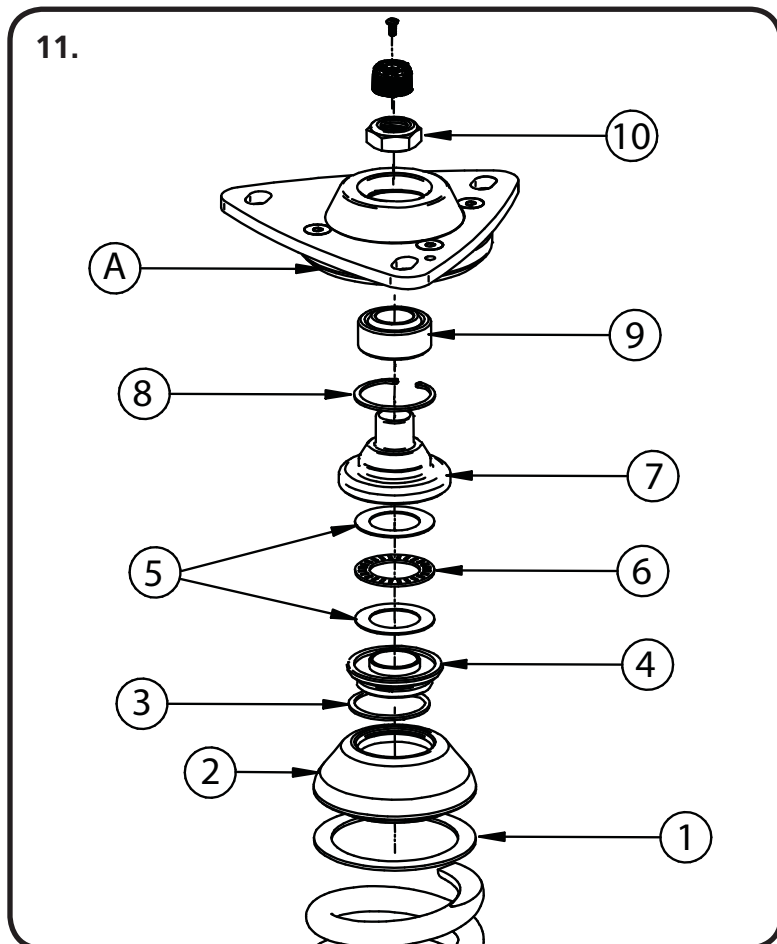

9. Remove the Adjuster Knob from the Strut shaft for assembly. With the CoilSpring installed on the Strut, bolt the strut assembly into the upper mount (A), see Diagram "9" for assembly order.

1. Delrin CoilSpring Washer
2. Upper CoilSpring Cap
3. CoilSpring Cap Retaining Ring (Installed On #4 CoilSpring to Bearing Adapter)
4. CoilSpring to Bearing Adapter
5. Torrington Bearing Races
6. Torrington Bearing
7. Bearing Adapter (Small Diameter Up)
8. Upper Mounting Bearing Snap Ring
9. Upper Mounting Bearing
10. 9/16" Locknut

Assemble components and install into upper mount tightening upper nut. Reinstall upper adjustment knob.

10. Slide the lower strut mount onto the spindle. Reuse the Factory hardware in the lower mounting hole. Insert the supplied Camber bolt into the top hole.

Lower Strut Attachment

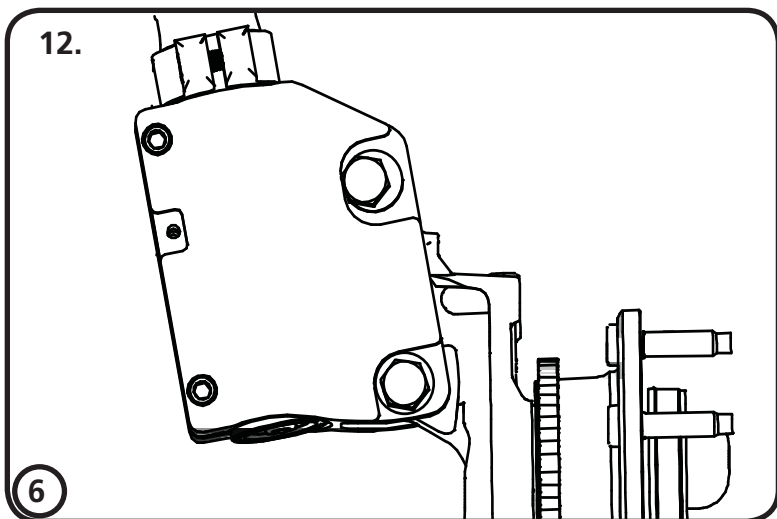

NOTE: THE STRUT TO SPINDLE ATTACHING BOLTS WILL NEED TO BE TORQUED TO 150 FTLBS TO KEEP IT FROM MOVING.

11. Reattach the OEM sway bar linkage to the strut housing using the OEM hardware.

12. Snap the ABS Wire into the Strut Mounts using the OEM retaining Clip that is attached to the Wire.



Final Assembly

13. Repeat previous steps on Passenger side.

14. With Both sides installed, slowly lower the car to the ground to check ride height. It may be necessary to tighten the Adjusting nut (Also known as preloading the CoilSpring) to achieve proper ride height. To do this you will need to loosen the Adjuster Nut Locking Screw and tighten the Adjuster Nut to put preload into the Coil-Spring. Once the correct ride height is achieved tighten the Locking Screw in the lower Adjuster nut. **It may be helpful to read the section pertaining to spring preload and adjustment below.**

IT IS NECESSARY TO HAVE THE CAR ALIGNED AFTER INSTALLATION. TORQUE THE STRUT TO SPINDLE ATTACHING BOLTS TO 150 FTLBS.

Spring Adjustment and Preload

Start with an initial preload of 1/4". The Locking Screw on the Adjuster Nut has to be loose to Set the Preload. To set this: Screw the Spring Adjuster up snug against the CoilSpring (THIS IS 0 PRELOAD). Measure from bottom of Adjuster Nut to top of the Strut Mount. Using Spanner, Tighten the Adjuster Nut until the measurement from the Nut to the Mount on the Shock is 1/4" greater. Tighten Locking Screw on Adjuster Nut. This will be your starting point for Ride Height. It may be necessary to raise or lower the adjuster to level the car.

Ride Height

We have designed most cars to have a ride height of about 2" lower than factory. To achieve the best ride quality & handling, the shock absorber needs to be at 40-60% overall travel when the car is at ride height. This will ensure that the shock will not bottom out or top out over even the largest bumps. Measuring the shock can be difficult, especially on some front suspensions. Measuring overall wheel travel is just as effective and can be much easier. Most cars will have 4-6" of overall wheel travel. One easy way to determine where you are at in wheel travel is to take a measurement from the fender lip (center of the wheel) to the ground. Then lift the car by the frame until the wheel is just touching the ground, re-measure. This will indicate how far you are from full extension of the shock. A minimum of 1.5" of extension travel (at the wheel) is needed to ensure that the shock does not top out. If you are more than 3" from full extension of the shock then you are in danger of bottoming out the shock absorber.

Adjusting Spring Height

When assembling the CoilOver, screw the spring retainer tight up to the spring (0 preload). After entire weight of car is on the wheels, jounce the suspension and roll the car forward and backward to alleviate suspension bind.

- If the car is too high w/ 0 preload then a smaller rate spring is required. Although threading the spring retainer down would lower the car, this could allow the spring to fall out of its seat when lifting the car by the frame.
- If the car is too low w/ 0 preload, then preload can then be added by threading the spring retainer up to achieve ride height. On 2.6" - 4" stroke shocks, up to 1.5" of preload is acceptable. On 5-7" stroke shocks, up to 2.5" of preload is acceptable. If more preload is needed to achieve ride height a stiffer spring rate is required. Too much preload may lead to coil bind, causing ride quality to suffer.



Strut Adjustment

Strut Adjustment 101- Single Adjustable

Rebound Adjustment:

How to adjust your new struts.

The rebound adjustment knob is located on the top of the Strut protruding through the upper mount.

You must first begin at the ZERO setting, then set the shock to a soft setting of 20.



-Begin with the Strut adjusted to the ZERO rebound position (full stiff). Do this by rotating the rebound adjuster knob clockwise until it stops.

-Now turn the rebound adjuster knob counter clock wise 20 clicks. This sets the shock at 20. (settings 21-24 are typically too soft for street use).

Take the vehicle for a test drive.



-If you are satisfied with the ride quality, do not do anything, you are set!

-If the ride quality is too soft increase the damping effect by rotating the rebound knob clock wise 3 clicks.

Take the vehicle for another test drive.



-If the vehicle is too soft increase the damping effect by rotating the rebound knob clock wise 3 additional clicks.

-If the vehicle is too stiff rotate the rebound adjustment knob counter clock wise 2 clicks and you are set!

Take the vehicle for another test drive and repeat the above steps until the ride quality is satisfactory.

Note:

One end of the vehicle will likely reach the desired setting before the other end. If this happens stop adjusting the satisfied end and keep adjusting the unsatisfied end until the overall ride quality is satisfactory.



Strut Adjustment

Shock adjustment 101- Triple Adjustable

Triple Adjustable:

Step One: High Speed Compression



- High speed compression adjustments are used in both street driving and track tuning.
- Begin with the shocks adjusted to the ZERO high speed compression position (full stiff). Do this by rotating the high speed compression adjuster (large knob) clockwise until it stops.
- Now turn the high speed compression adjuster knob counter clock wise 20 clicks. This sets the shock at 20. (settings 21-24 are typically too soft for street use. For typical street driving the high speed compression adjuster will remain at setting 20.

Step Two: Low Speed Compression

Low speed compression adjustment is what is typically felt during street driving.



- Begin with the shocks adjusted to the ZERO low speed compression position (full stiff). Do this by rotating the low speed compression adjuster (small knob) clockwise until it stops.
- Now turn the low speed compression adjuster knob counter clock wise 20 clicks. This sets the shock at 20. (settings 21-24 are typically too soft for street use). Take the vehicle for a test drive.
- if you are satisfied with the ride quality, do not do anything, you are set!
- if the ride quality is too soft increase the damping effect by rotating the low speed compression knob clock wise 3 clicks.

Take the vehicle for another test drive.



- if the vehicle is too soft increase the damping effect by rotating the low speed compression knob clock wise 3 additional clicks.
- If the vehicle is too stiff rotate the low speed compression adjustment knob counter clock wise 2 clicks and you are set!

Take the vehicle for another test drive and repeat the above steps until the ride quality is satisfactory.

Step 3:

Adjust rebound according to Single Adjustable instructions.

Note:

One end of the vehicle will likely reach the desired setting before the other end. If this happens stop adjusting the satisfied end and keep adjusting the unsatisfied end until the overall ride quality is satisfactory.



Part # 12276111 - 2015 up Mustang TQ Rear CoilOvers

Recommended Tools

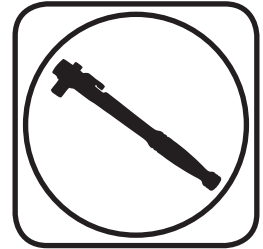
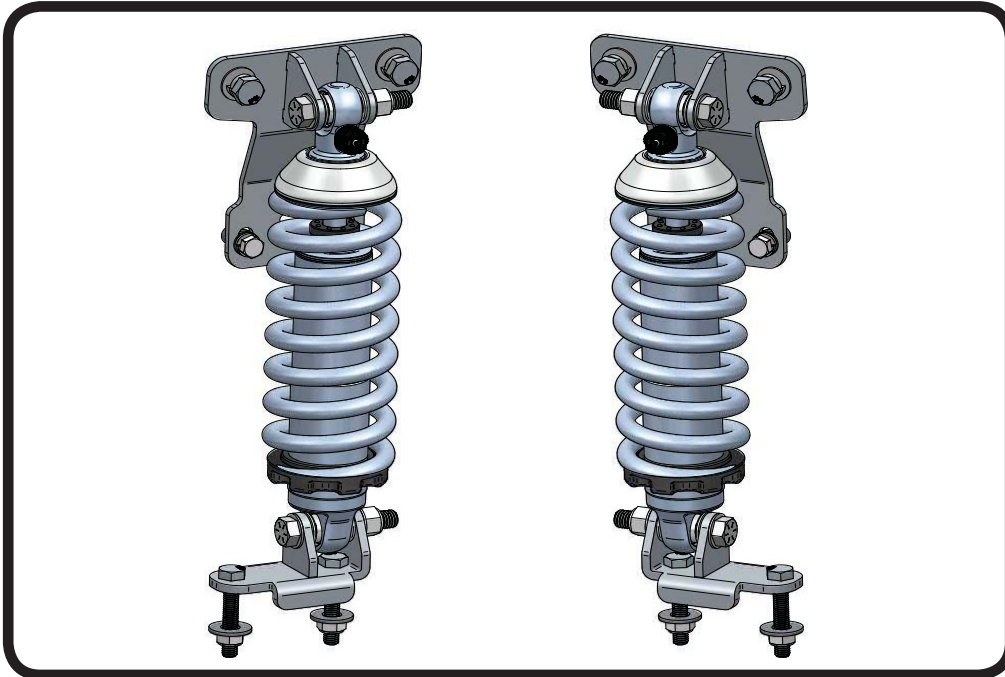

2015 up Mustang TQ Series Rear CoilOvers Installation Instructions

Table of contents

Page 11.....	Included components
Page 12.....	Getting Started and Disassembly
Page 13.....	CoilOver Assembly
Page 14-16.....	CoilOver Installation
Page 17.....	CoilSpring Adjusting
Page 18-19.....	Shock Adjustment





Major ComponentsIn the box

Item	Part #	Description	QTY
1	24359999	5.2" Stroke HQ Series Shock	2
2	59100550	10" 550lb CoilSpring	2
3	90002024	1.7" Eyelet	2
4	70010828	Delrin CoilSpring Washer	4
5	90002480	Upper Shock Mount	2
6	90002482	Lower Shock Mount; Driver	1
6	90002483	Lower Shock Mount; Passenger (Not Shown)	1
7	90002070	Dropped Upper CoilSpring Mount	2
8	90002222(kit)	CoilSpring Plate Retaining Ring	2
8	90002222(kit)	Lower Spring Adjuster Nut (90002222 kit)	2
8	90002222(kit)	Adjuster Nut Locking Screw (90002222 kit)	2
9	90002043	Shock Spacer	2
10	99372007	3/8"-16 Riv-Nut	2
11	99371004	3/8"-16 x 1 1/4" Hex Bolt	4
12	99373005	3/8" Lockwasher	4
13	99373003	3/8" SAE Flatwasher	4
14	99121005	M12-1.75 x 30mm Hex Bolt	4
15	99503002	1/2" Lockwasher	4
16	99503001	1/2" SAE Flat Washer	4
17	99501003	1/2"-13 x 2 1/2" Hex Bolt	4
18	99503001	1/2" Flatwasher	8
19	99502009	1/2"-13 Nylok Nut	4
20	99371048	3/8"-16 x 2" Hex Head Bolt	2
21	99373003	3/8" Flatwasher	4
22	99372002	3/8"-16 Nylok Nut	4
23	99371036	3/8"-16 x 2" Square Head Bolt	2
	90001995	Bearing Snap Ring (Installed in Shock Body)	8
	90001994	5/8" ID Bearing (Installed in Shock Body)	4
	70012266	Sway Bar Relocator (Not Shown)	2
	99371001	3/8"-16 x 1" Hex Bolt	4
	90002221	Reservoir Mounts	4
	99050000	Reservoir Mounting Screw	12
	85000003	Reservoir Screw Allen Wrench	1

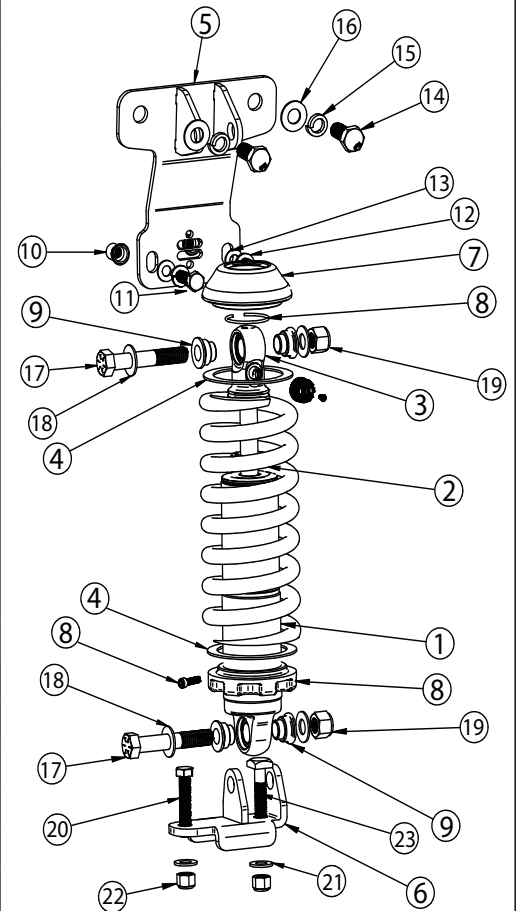



Installation Instructions



Getting Started and Disassembly

Congratulations on your purchase of the Ridetech Mustang CoilOver System. This system has been designed to give your Mustang excellent handling along with a lifetime of enjoyment. The CoilOver System provides flexibility that can not be achieved with Conventional CoilSprings. The CoilOver System will give you the flexibility of adjusting your ride height along with numerous spring options to dial in your ride quality to your personal preference.

This CoilOver System is Designed to replace the factory Shock and CoilSprings.

Refer to the Factory Service Manual for disassembly and CoilSpring removal instructions.

1. Remove the Shocks and the OEM Upper Shock Mount from the Car.
2. Remove the Sway Bar Linkage from the car. These will be reinstalled, but flipped around for more clearance.
3. Remove the Sway Bar from the car. Again, this we get reinstalled later, but it will be relocated for clearance.

This Kit utilizes Riv-nut on the Upper CoilOver Mount. An Instruction sheet is supplied for the Riv-nut installation. Read the Riv-nut Instruction Sheet on how to install the Riv-nut. A Drill Bit and Installation Tool is supplied with this kit. The Upper Mount will be used as a guide for drilling the holes.

To get Started refer to the page 4 on how to assemble the CoilOver



CoilOver Assembly

4.

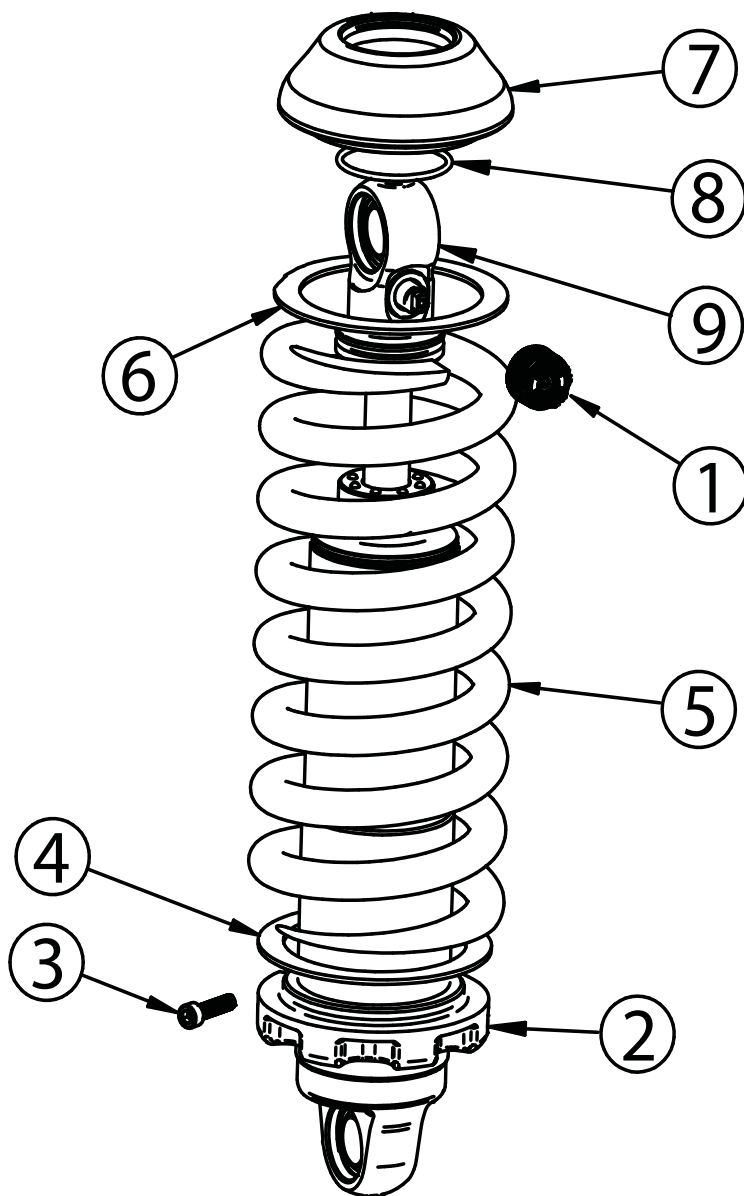

4. To Assemble the CoilOver you need to:

- a. Turn Adjuster Knob all the way in (Clockwise)
. Remove Screw from center of Adjustment Knob (1) and remove Adjustment Knob.
- b. Thread Adjuster Nut (2) onto the CoilOver body. Once it is threaded on the shock body, lightly thread in the locking screw (3) into the Adjuster Nut.
- c. Install a Delrin Spring Washer (4) onto the Adjuster Nut.
- d. Slide the CoilSpring (5) onto the CoilOver.
- e. Install another Delrin Spring Washer (6) on top of the CoilSpring.
- f. Install the Upper Drop CoilSpring Cap (7) onto the CoilSpring.
- g. Install the CoilSpring Retaining Ring (8) onto the Upper Eyelet (9). It fits into the groove in the base.
- h. Reinstall Adjuster Knob

Repeat on second CoilOver.



CoilOver Installation

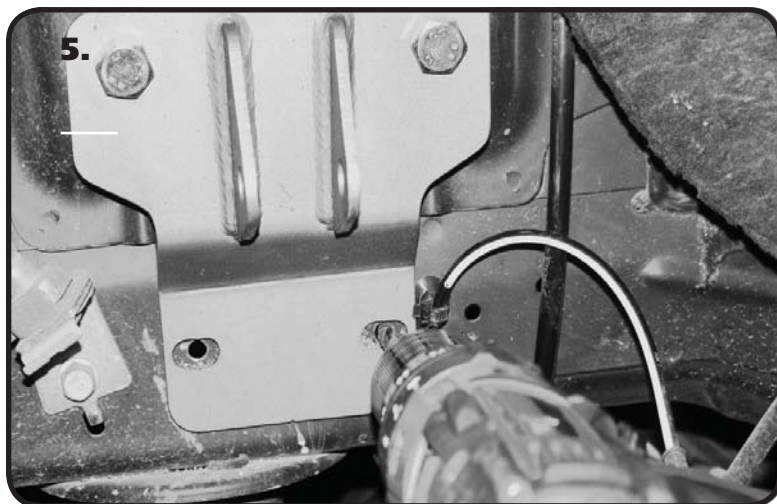

5. Bolt the Upper CoilOver Mount into the OEM location using (2) M12-1.75 x 30mm Hex Bolts, (2) 1/2" Lockwashers, & (2) 1/2" Lockwashers. Tighten enough to hold in place. Use the Shock Mount as a guide to drill a hole in the center of each slot using the 17/32" Drill Bit supplied in the kit. After the holes are drilled, remove the Upper Shock Mount.

Repeat for both sides.

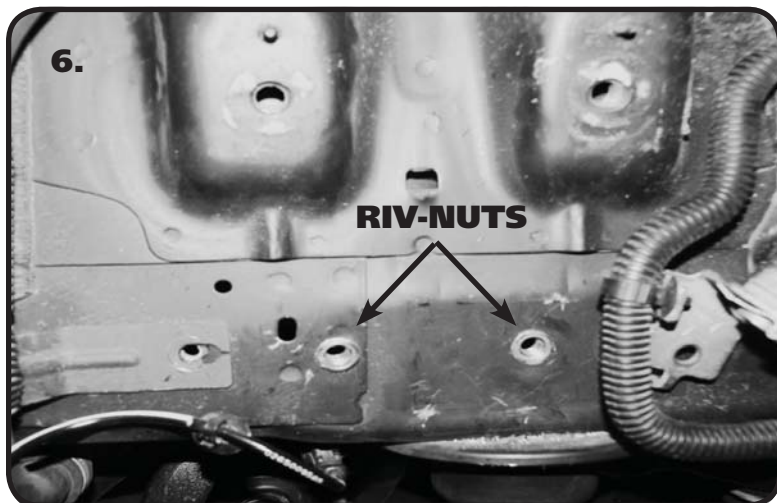

6. Install (2) Riv-nuts using the supplied Tool and instructions for Riv-nut installation. Do this for both sides.



7. Reinstall the Upper Shock Mount as in Step 11, adding (2) 3/8"-16 x 1 1/4" Hex Bolts, (2) 3/8" Flatwashers, & (2) 3/8" Lockwashers in the bottom 2 Holes. Tighten all Hardware. Torque the Riv-Nut Bolts to 23 ftlbs.



CoilOver Installation

8.

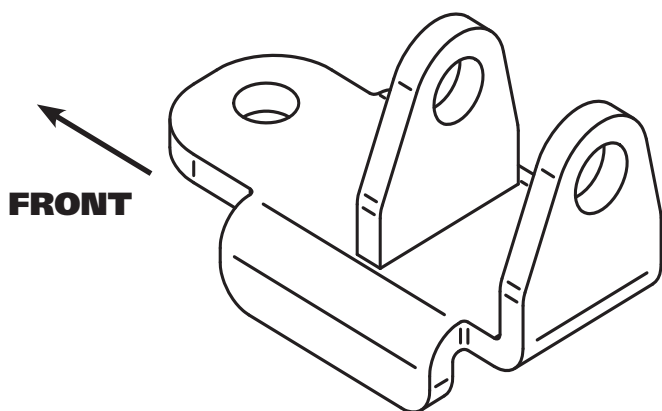

8. Illustration "14" Shows the Driver Lower Shock Mount. The Shock Mount offsets the Shock to the rear of the Car.

9.

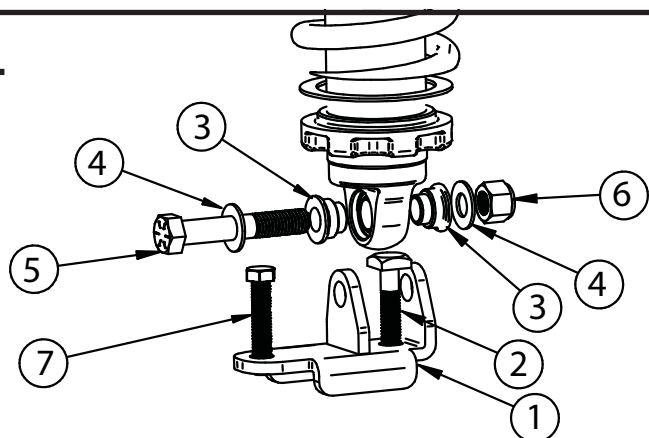

9. Insert (1) 3/8"-16 x 2" Square Head Bolt[2] into the Lower Shock Mount[1] between the 2 Shock Tabs. Insert (2) Bearing Spacers[3] into the Bearing in the Shock Body of the assembled CoilOver. Slide the CoilOver into the Lower Shock Mount, aligning the hole in the Mount with the Bearing Spacers. Slide a 1/2" Flatwasher[4] onto a 1/2"-13 x 2 1/2" Hex Bolt[5] and insert the Bolt/Washer into the Lower Shock Mount/Shock. Install a 2nd 1/2" Washer[4] followed by a 1/2" Nylok. Tighten the Lower Shock Bolt. Insert a 3/18"-16 x 2 Hex Bolt[7] into the remain hole in the Lower Shock Mount. Repeat for Passenger side. Torque 1/2"-13 x 2 1/2" Bolt to 75 ftlbs.

10.



10. Install the CoilOver/Lower Shock Mount Assembly on the Driver Lower Control Arm in the OEM Shock location. With the Assembly in place, insert a 7/16" Flatwasher on the 3/8"-16 x 2" Bolts sticking through the OEM Control Arm, Followed by a 3/8"-16 Nylok Nut. Tighten Hardware.

Note: One of the Flats on the Hex Bolt under the CoilOver will lock against the Shock Tab allowing it to be tightened.



CoilOver Installation

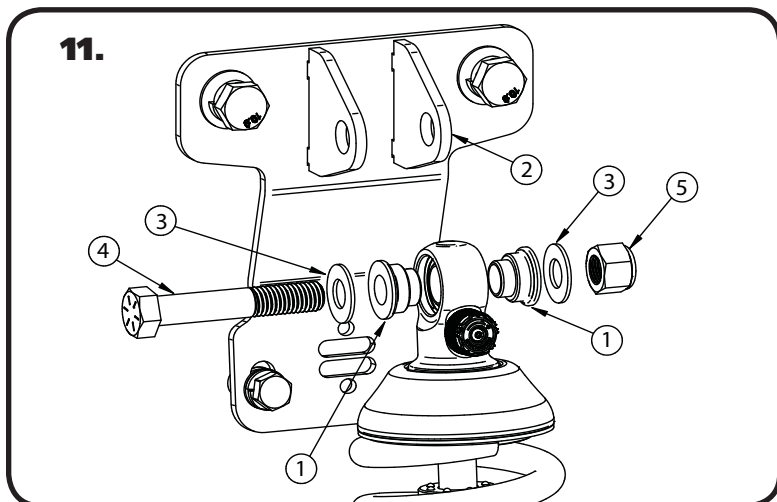

11. Insert Bearing Spacers[1] into each side of the Bearing in the Upper CoilOver Eyelet. Slide the CoilOver into the Upper Shock Mount[2] aligning the holes in the Upper Mount with the holes in the Bearing Spacers. You may have to Jack the Lower Control arm up to get the holes to align. Install a 1/2" Flatwasher[3] onto a 1/2"-13 x 3" Hex Bolt[4] and install it through the Shock Mount and Bearing Spacer holes. Install a 1/2" Flatwasher[3] on the Bolt, followed by a 1/2"-13 Nylok Nut[4].



12. Install the SwayBar Relocators using the OEM Hardware to attach the Mount. The Bracket should be bolted to the car with the Threaded Holes to the REAR of the car. Tighten the OEM Hardware. Install the SwayBar using (4) 3/8"-16 x 3/4" Hex Bolts and (4) 3/8" Flatwashers.



13. Reinstall the SwayBar Linkage using the OEM Hardware with the Studs Pointing TOWARDS THE COILOVER. Repeat for both sides.



Setting Preload & CoilSpring Adjusting

Start with an initial preload of 1/2". The Locking Screw on the Adjuster Nut has to be loose to Set the Preload. To set this: Screw the Spring Adjuster up snug against the CoilSpring (THIS IS 0 PRELOAD). Measure from bottom of Adjuster Nut to Flat on Shock. Using Spanner, Tighten the Adjuster Nut until the measurement from the Nut to the Flat on the Shock is 1/2" greater. Tighten Locking Screw on Adjuster Nut. This will be your starting point for Ride Height. It may be necessary to raise or lower the adjuster to level the car.

Ride Height

We have designed most cars to have a ride height of about 1 1/2" lower than factory. To achieve the best ride quality & handling, the shock absorber needs to be at 40-60% overall travel when the car is at ride height. This will ensure that the shock will not bottom out or top out over even the largest bumps. Measuring the shock can be difficult, especially on some front suspensions. Measuring overall wheel travel is just as effective and can be much easier. Most cars will have 4-6" of overall wheel travel. One easy way to determine where you are at in wheel travel is to take a measurement from the fender lip (center of the wheel) to the ground. Then lift the car by the frame until the wheel is just touching the ground, re-measure. This will indicate how far you are from full extension of the shock. A minimum of 1.5" of extension travel (at the wheel) is needed to ensure that the shock does not top out. If you are more than 3" from full extension of the shock then you are in danger of bottoming out the shock absorber.

Adjusting Spring Height

When assembling the CoilOver, screw the spring retainer tight up to the spring (0 preload). After entire weight of car is on the wheels, jounce the suspension and roll the car forward and backward to alleviate suspension bind.

- If the car is too high w/ 0 preload then a smaller rate spring is required. Although threading the spring retainer down would lower the car, this could allow the spring to fall out of its seat when lifting the car by the frame.
- If the car is too low w/ 0 preload, then preload can then be added by threading the spring retainer up to achieve ride height. On 2.6" - 4" stroke shocks, up to 1.5" of preload is acceptable. On 5-7" stroke shocks, up to 2.5" of preload is acceptable. If more preload is needed to achieve ride height a stiffer spring rate is required. Too much preload may lead to coil bind, causing ride quality to suffer.



Shock Adjustment

Shock adjustment 101- Single Adjustable

Rebound Adjustment:

How to adjust your new shocks.

The rebound adjustment knob is located on the top of the shock absorber protruding from the eyelet.

You must first begin at the ZERO rebound setting, then set the shock to a soft setting of 20.



-Begin with the shocks adjusted to the ZERO rebound position (full stiff). Do this by rotating the rebound adjuster knob clockwise until it stops.



-Now turn the rebound adjuster knob counter clock wise 20 clicks. This sets the shock at 20. (settings 21-24 are typically too soft for street use).

Take the vehicle for a test drive.



-if you are satisfied with the ride quality, do not do anything, you are set!



-if the ride quality is too soft increase the damping effect by rotating the rebound knob clock wise 3 clicks. **CONTINUE ON NEXT PAGE.**

Take the vehicle for another test drive.



-if the vehicle is too soft increase the damping effect by rotating the rebound knob clock wise 3 additional clicks.



-If the vehicle is too stiff rotate the rebound adjustment knob counter clock wise 2 clicks and you are set!

Take the vehicle for another test drive and repeat the above steps until the ride quality is satisfactory.

Note:

One end of the vehicle will likely reach the desired setting before the other end. If this happens stop adjusting the satisfied end and keep adjusting the unsatisfied end until the overall ride quality is satisfactory.

STILL HAVE QUESTIONS?

Tech line hours

Monday - Friday

8AM - 6PM (EST) 812-482-2932

www.ridetech.com
812-482-2932



Shock Adjustment

Shock adjustment 101- Triple Adjustable

Triple Adjustable:

Step One: High Speed Compression



- High speed compression adjustments are used in both street driving and track tuning.
- Begin with the shocks adjusted to the ZERO high speed compression position (full stiff). Do this by rotating the high speed compression adjuster (large knob) clockwise until it stops.
- Now turn the high speed compression adjuster knob counter clock wise 20 clicks. This sets the shock at 20. (settings 21-24 are typically too soft for street use. For typical street driving the high speed compression adjuster will remain at setting 20.

Step Two: Low Speed Compression

Low speed compression adjustment is what is typically felt during street driving.



- Begin with the shocks adjusted to the ZERO low speed compression position (full stiff). Do this by rotating the low speed compression adjuster (small knob) clockwise until it stops.
- Now turn the low speed compression adjuster knob counter clock wise 20 clicks. This sets the shock at 20. (settings 21-24 are typically too soft for street use). Take the vehicle for a test drive.
- if you are satisfied with the ride quality, do not do anything, you are set!
- if the ride quality is too soft increase the damping effect by rotating the low speed compression knob clock wise 3 clicks.

Take the vehicle for another test drive.



- if the vehicle is too soft increase the damping effect by rotating the low speed compression knob clock wise 3 additional clicks.
- If the vehicle is too stiff rotate the low speed compression adjustment knob counter clock wise 2 clicks and you are set!

Take the vehicle for another test drive and repeat the above steps until the ride quality is satisfactory.

Step 3:

Adjust rebound according to Single Adjustable instructions.

Note:

One end of the vehicle will likely reach the desired setting before the other end. If this happens stop adjusting the satisfied end and keep adjusting the unsatisfied end until the overall ride quality is satisfactory.