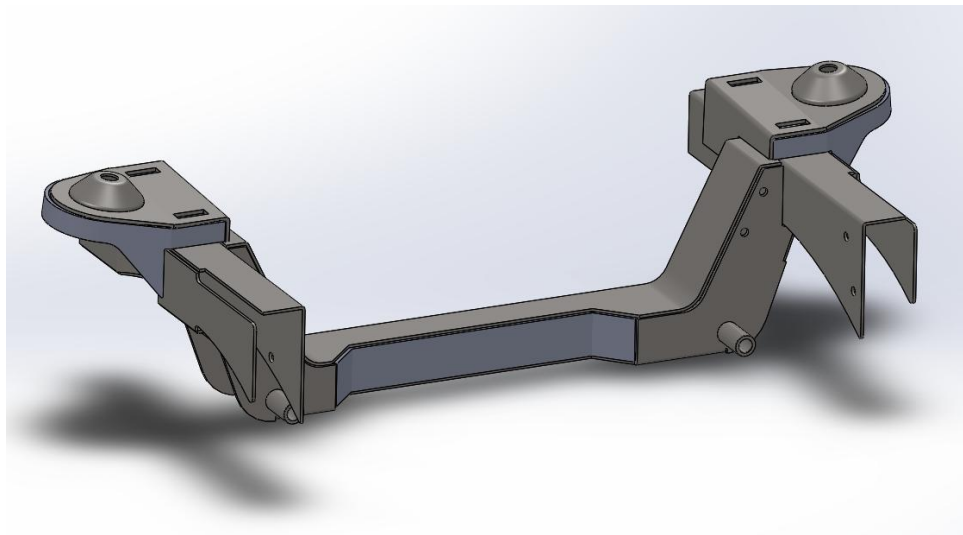




**INSTALLATION INSTRUCTIONS**  
**64 ½ - 70 MUSTANG II**  
**INDEPENDENT FRONT SUSPENSION**  
**(PM-320-E-K)**



Please read these instructions *completely*  
**before** starting your installation.

**Assemble suspension on vehicle** before powder-coating to ensure proper fitment, and to make modifications if necessary.

For questions on installations please call 800-841-8188 In Illinois (847) 487-0150



## PARTS LIST

- |                        |                        |
|------------------------|------------------------|
| 1) Mustang II Subframe | 2) Spring Hats         |
| 2) Spindles            | 1) Sway Bar            |
| 2) Upper Control Arms  | 1) Power Rack & Pinion |
| 2) Lower Control Arms  | 2) Front Shocks        |
| 2) Springs             | 1) Wilwood Brake Kit   |

## HARDWARE PACKAGE

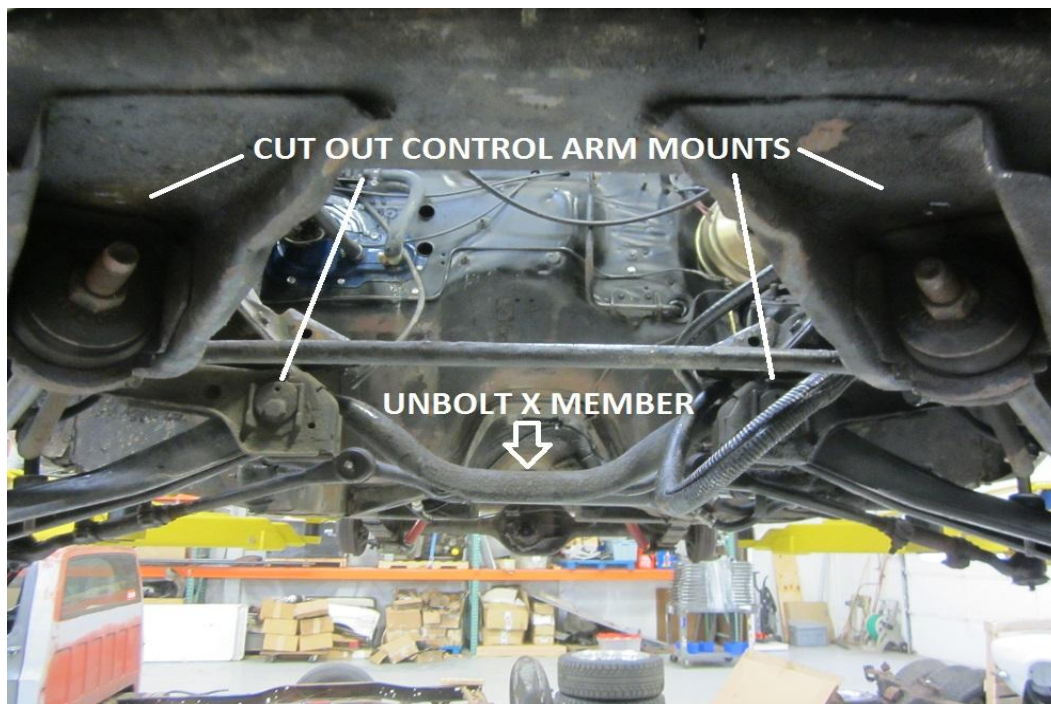
- |                         |                                 |
|-------------------------|---------------------------------|
| 4) 7/16-14 Nylock Nut   | 4) 7/16-14 x 1 ½" Hex Bolt      |
| 8) 7/16 Washer          | 2) Sway bar end link assemblies |
| 4) 3/8-16 x 3" Hex Bolt | 4) 3/8-16 Nylock Nut            |
| 8) 3/8 Washers          |                                 |

For questions on installations please call 800-841-8188 In Illinois (847) 487-0150



You are about to install your HEIDTS suspension system. You are probably wondering how complicated installing a complete I.F.S. system really is, with all those pieces, all the angles, anti-dive, geometry ...Don't worry. The HEIDTS I.F.S. kits are designed so all that is taken care of for you. Just follow the instructions step by step, reading each step completely, and in a very short time your car will be sitting on the nicest riding I.F.S. kit available.

1) Begin your installation by jacking up your vehicle and supporting it on sturdy jack stands. The stands must be placed on the flat section of the frame rails close to the front body mounts. First remove the engine and transmission. **SAVE AND LABEL ALL FASTENERS FOR RE-INSTALLATION!** Remove the front wheels and shocks. Disconnect the brake lines and tie-rods. Next, remove the old steering box, pitman arm and lower control arms. After this, unbolt the factory crossmember from the frame. Cut the factory lower control arm mounts out. (See **Figure 1**).



**Figure 1**

For questions on installations please call 800-841-8188 In Illinois (847) 487-0150



2) After the crossmember, lower control arms and mounts are removed, cut out the factory shock towers. Use the edge between the shock tower and the inner apron to get a clean cut of the shock tower. We provide Inner Fender Panels to go in place of the cut out shock tower.  
(See Figures 2 and 3)



**Figure 2**



**Figure 3**

3) Grind away and clean the rest of the front frame rails. It is important to have the entire frame rails cleaned for good clean welds. Clean away top, bottom, inner and outer frame rails.  
(See Figure 4).



**Figure 4**

#### **Bottom view of Engine Bay**

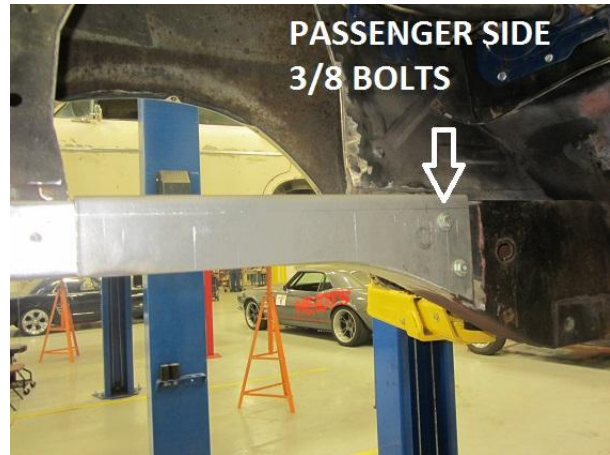
For questions on installations please call 800-841-8188 In Illinois (847) 487-0150



4) Place the inner boxing plates inside the frame rails as shown in **Figure 5**. Use 7/16 bolts on the drivers side in place of the factory steering box. Use 3/8 bolts on the passenger side in place of the idler arm. Bolt up the Inner boxing plates using the pre cut holes. Make sure boxing plates sit flat on the top frame rail. Grind away any interference. (See **Figures 5 and 6**).



**Figure 5**

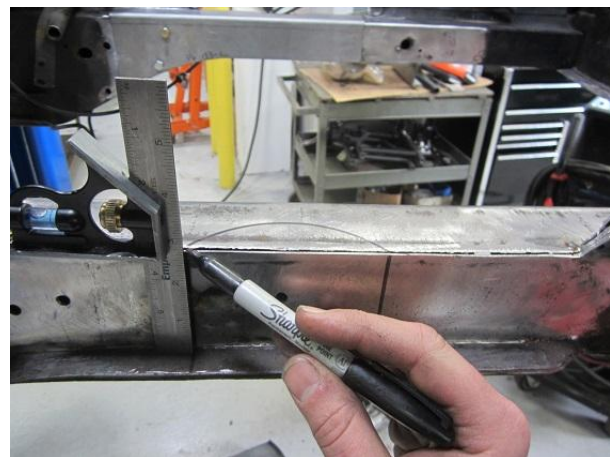


**Figure 6**

5) Mark with a sharpie or scribe the spring cut out. Use a straight edge to mark the side rails. Using the outer boxing plate as a template, mark the ends and cut the factory strip of material as shown in **Figure 10**. Cut on the lines and remove the material for spring clearance. Do this for both sides of the car. (See **Figures 7-10**).



**Figure 7**



**Figure 8**

For questions on installations please call 800-841-8188 In Illinois (847) 487-0150





**Figure 9**

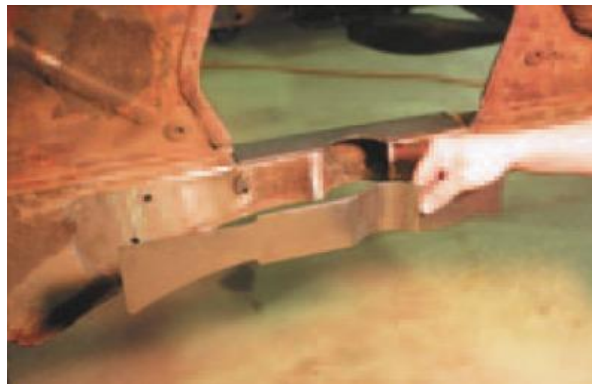


**Figure 10**

6) Once the cut out is complete, the boxing plates can be tack welded to the frame. Clamp the bottom boxing plate to the frame aligning the bottom boxing plate to the side boxing plate. The outer boxing plate radius aligns with the cut out for the coil spring. (See Figures 11-14).



**Figure 11**



**Figure 12**



**Figure 13**



**Figure 14**

For questions on installations please call 800-841-8188 In Illinois (847) 487-0150



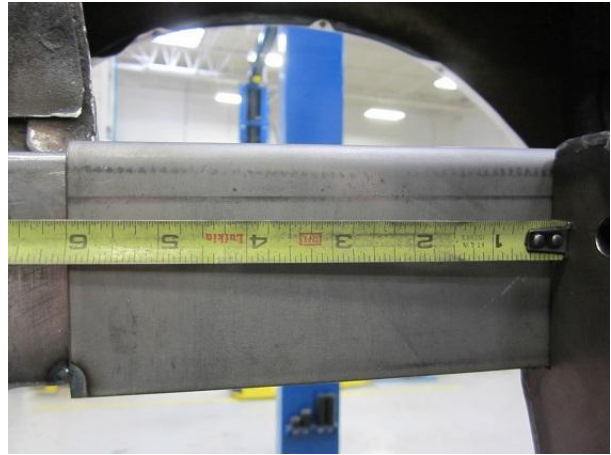
7) The bottom boxing plate can be welded at this time. The reason is so the crossmember can be installed and measured multiple times before fully welding the boxing plates.

**\*\*\*Level the car front to rear at this point. This will be important for steps 8 and 9.\*\*\***

8) Place the crossmember inside the frame rails as shown in **Figure 15**. Measure from the front of the crossmember (around the motor mount area) to the front of the un-welded boxing plate. The dimension is 6" as shown in **Figure 16**. Another reference from the front of the frame to front of the cross member 24 1/4". (See **Figures 15-18**).



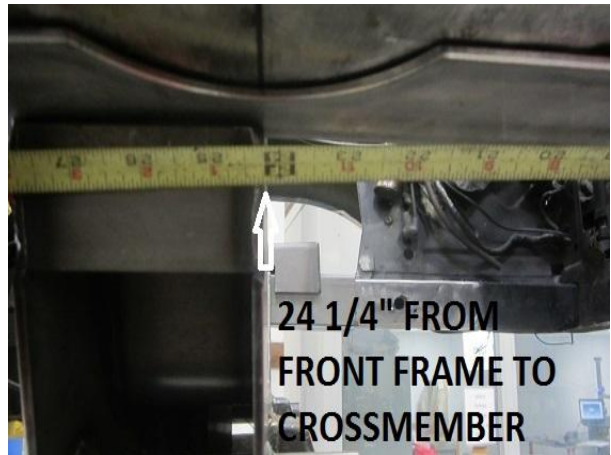
**Figure 15**



**Figure 16**



**Figure 17**



**Figure 18**

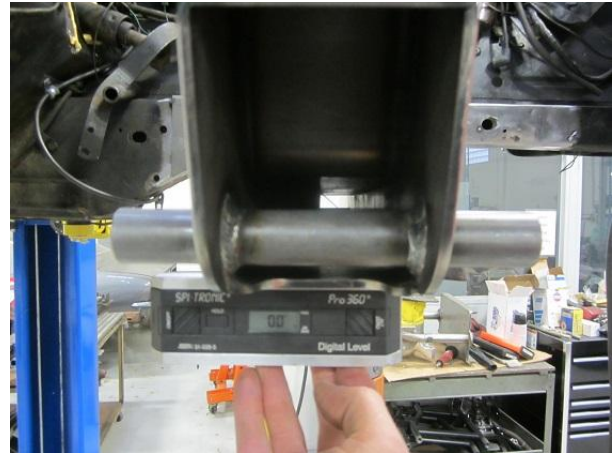
For questions on installations please call 800-841-8188 In Illinois (847) 487-0150



9) Level the front crossmember front to back before tack welding. **See Figure 19.** Tack the front crossmember in at the desired location. Measure again to verify the correct dimensions and level crossmember one more time before fully welding the boxing plates and front crossmember into the frame. **(See Figures 19 and 20).**

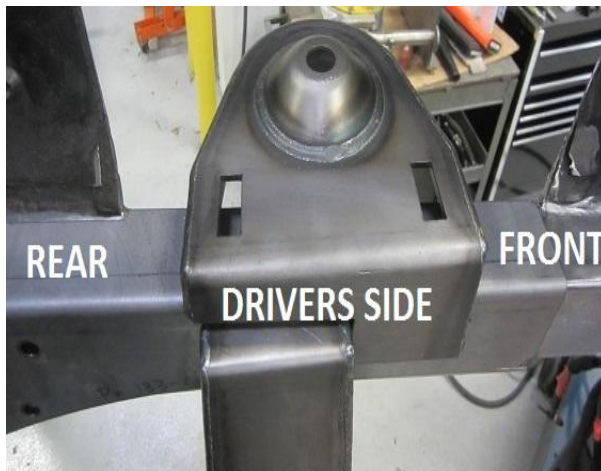


**Figure 19**

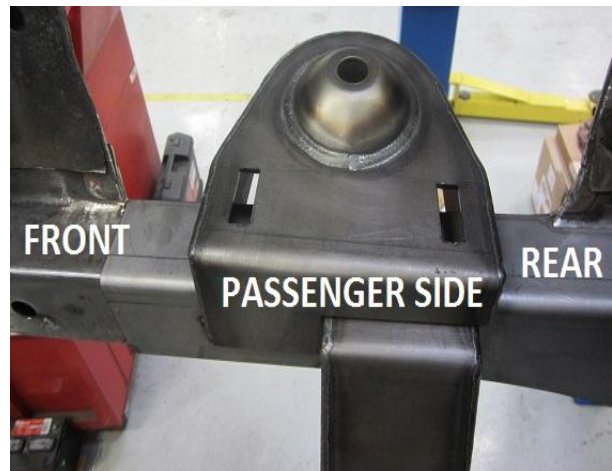


**Figure 20**

10) After the boxing plates and front crossmember are fully welded, place the spring hats on top of the frame rails and cross member as shown in **Figures 21 and 22.** Tack the spring hats in place and verify the correct location before fully welding into the car. **(See Figures 21 and 22).**



**Figure 21**



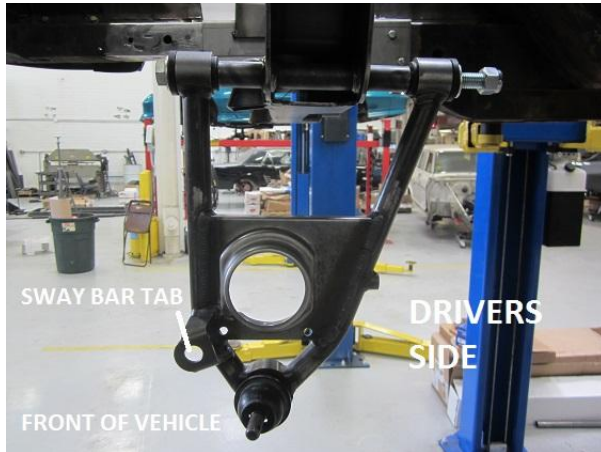
**Figure 22**

For questions on installations please call 800-841-8188 In Illinois (847) 487-0150





11) After the boxing plates, crossmember and spring hats are fully welded, the lower control arms can be installed. Bolt the lower control arm to the front crossmember using 5/8-11 x 13" bolts, washers and 5/8-11 nylock nuts. See Figures 23-24.



**Figure 23**



**Figure 24**

12) Install the upper control arms using the 12 mm T-Bolts and 12 mm flanged lock nuts from the control arm hardware kit. Ball Joint grease fittings may be also installed at this point. See Figures 25 and 26.



**Figure 25**

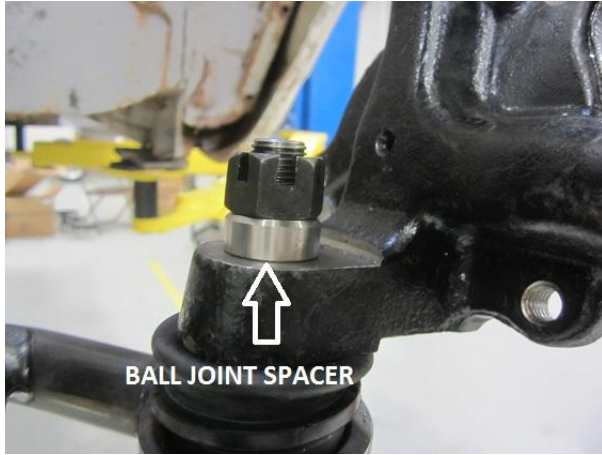


**Figure 26**

For questions on installations please call 800-841-8188 In Illinois (847) 487-0150



13) Install the spindles onto the lower ball joints. Use the stainless steel ball joint spacer in the hardware kit as shown in **Figure 27**. This is a good time to install the coil spring insulator shown in **Figure 28**.



**Figure 27**



**Figure 28**

14) The coil springs may be installed next. Use a spring compressor to compress the coil springs to be installed in the spring pockets and squeezed in by the lower control arm. Once the compressed spring is seated in the spring pocket and lower control arm, raise the lower control arm with a floor jack and connect the upper ball joint to the spindle. See **Figures 29-31**.

*\*The springs will be completely seated roughly around 500 miles of driving\**



**Figure 29**



**Figure 30**

For questions on installations please call 800-841-8188 In Illinois (847) 487-0150





**Figure 31**

15) Install the shock absorbers as shown in **Figures 21-24**. Place the washer and rubber grommet onto the shaft of the shock absorber. Use anti-seize on the lower shock mount 7/16-14 bolt. Install the shock absorber through the coil spring and install the grommet and washer on top of the spring hat. Tighten with the 3/8 lock nut. Compress the shock until the shock mounts are flush on the lower control arm. Thread the 7/16-14" bolt through the shock mounts to fully install the shock absorber. See **Figures 32-35**.



**Figure 32**



**Figure 33**

For questions on installations please call 800-841-8188 In Illinois (847) 487-0150





**Figure 34**



**Figure 35**

16) After the springs and shocks are completed, the rack and pinion can be installed. Use the 5/8-11 x 3" hex bolts, flanged lock nuts and rack mount spacers to mount the rack and pinion to the subframe mounts. Connect the outer tie rod ends snug to the spindle for wheel adjusting wheel alignment later. \*\*\* USE ANTI SEIZE ON OUTER TIE ROD THREADS\*\*\*. See **Figures 36-38**.



**Figure 36**



**Figure 37**

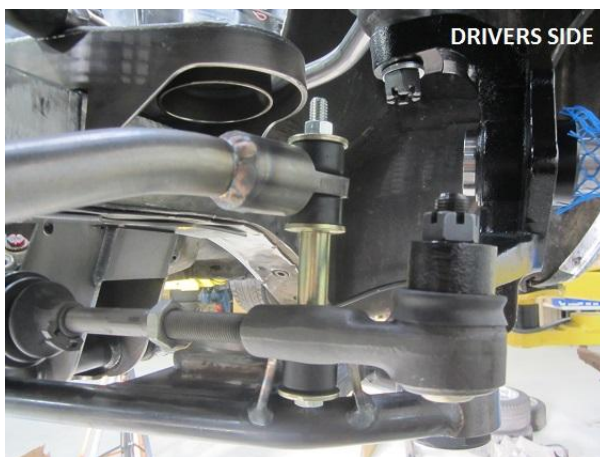
For questions on installations please call 800-841-8188 In Illinois (847) 487-0150





**Figure 38**

17) Mount the sway bar using the end links and bushings provided in the sway bar kit. Attach the sway bar to the end links and mount the end links snug to the lower control arm mounts. Make sure the end links are straight up and down front to rear and left to right. See **Figures 39 and 40**.



**Figure 39**

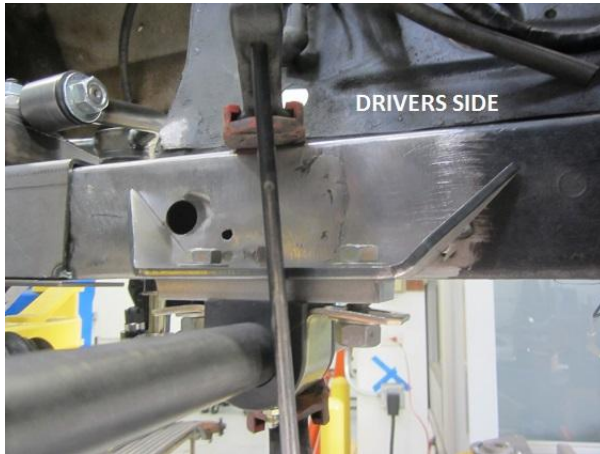


**Figure 40**

For questions on installations please call 800-841-8188 In Illinois (847) 487-0150



18) After the end links are snug to the lower control arms, install the sway bar bushings as shown in Figure 41. Use 7/16-14 x 1 1/2" grade 8 bolts, washers and nylock nuts to assemble the sway bar bushings and 3/8" spacers to the sway bar mounting brackets. Clamp the sway bar bushings and mounting bracket assembly to the factory frame. Double check the end link bushings to make sure they are straight up and down as described in step 17. Once the mounting bracket is flush with the bottom of the frame, tack weld the mounting bracket to the frame. See **Figures 41-43**.



**Figure 41**



**Figure 42**



**Figure 43**

For questions on installations please call 800-841-8188 In Illinois (847) 487-0150



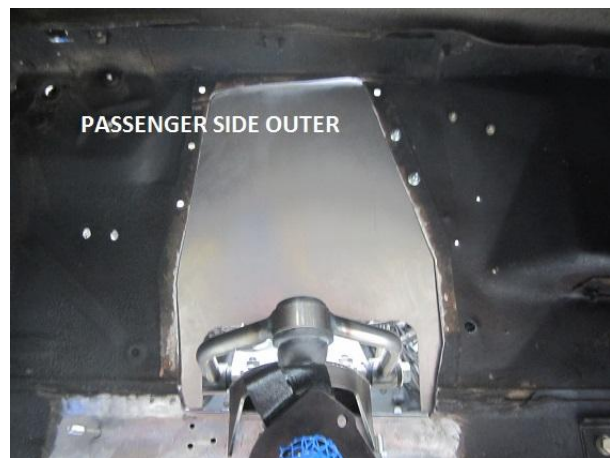
19) Once the sway bar is at desired location, fully weld the sway bar mounting brackets to the frame.

**\*\*\*Installing the engine and transmission is recommended prior to installing the Inner Fender Panels. This eases the placement of the engine and exhaust.\*\*\***

20) With the suspension, sway bar and rack and pinion completed , the inner fender panels can be installed. The inner fender panels mount in the previous location of the factory shock towers. Use the 5/16-18 x 3/4" bolts and flange nuts to secure the inner fender panels to the inner aprons. Inner Panels may need minor trimming for better fit. There are a few holes that do not exist that need to be drilled 5/16 to complete the installation. See **Figures 44 and 45**.



**Figure 44**



**Figure 45**

Lastly, you are ready to set the alignment of your vehicle. Be sure to do so with the arms and shocks set at ride height (the lower control arms should be level). The caster and camber settings are done with the slots in the upper control arm mounts. Both adjusters are screwed in or out an equal amount to change the camber, and they are adjusted opposite each other to change caster. The interesting thing about the caster setting is that you can experiment with different settings and actually "tune" the characteristics of the handling of your vehicle to your driving style. 3° of caster will give a nice road feel and good low speed drive-ability. 4° or 5° will yield better high speed stability and tracking, putting a better self-centering characteristic in the steering wheel, but will tend to start to make parking slightly more difficult. Just be sure that both sides have equal caster settings, or the vehicle will tend to pull to one side.

For questions on installations please call 800-841-8188 In Illinois (847) 487-0150



## **Alignment Specifications:**

**Caster: 1° to 3° Positive**

**Camber: 0° to - 0.5° Negative**

**Toe: 0.0" to - 1/16" Toe-In**

Since you are now to the point where you have a finished, running Mustang (we hope!) it is time to test drive it. After a few hundred miles, double check the ride height and the alignment. The springs may have settled, which would change the ride height and the camber setting. Readjust the ride height before changing the alignment. After this initial setting period, the springs and bushings should have pretty much taken their final set, so you should be on your way to many miles of cruising in style.

For questions on installations please call 800-841-8188 In Illinois (847) 487-0150

