



Part # 12095010 - 1964-1966 Mustang StreetGrip

Front Components

12099590	Delrin Control Arm Bushings
12092350	Front Dual Rate CoilSprings
12099515	Front HQ Series Shock Kit
12099120	Front SwayBar

Rear Components

12094799	Composite Leaf Springs
12095399	Delrin Leaf Spring Bushings
12099510	Rear HQ Series Shock Kit

Recommended Tools

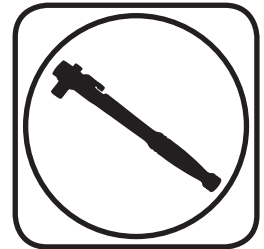

1964-1966 Mustang StreetGrip Installation Instructions

Table of contents

Page 2.....	Major components and Hardware List
Page 3.....	Getting Started
Page 4-8.....	Delrin Bushings
Page 9.....	Front Dual Rate CoilSpring
Page 10-13.....	Front SwayBar
Page 13-16.....	Front HQ Series Shock Kit
Page 16-19.....	Composite Leaf Springs & Delrin Bushings
Page 19-24.....	Rear HQ Series Shock Kit

The majority of the StreetGrip components will be installed together. For example, the Front CoilSprings, Control Arm Bushings and Shock Kit will be installed in conjunction with each other. On the rear, the Leaf Springs, Delrin Bushings and Shock Kit will be installed in conjunction with each other. The front SwayBar will need to be installed **after** the rest of the front components are installed.





Major ComponentsIn the box

Part #	Description	QTY
55490792	Front CoilSprings- Small Block	2
12094799	Rear Leaf Springs w/ Delrin Bushings & Inner Sleeves Installed	2
90002556/90002610	Leaf Spring Clamp Plate/Lower Shock Mount D & P	2
90002626	1 1/2" Lowering Block w/70012898 pressed in	2
90002655	Upper Cross Shaft	2
70012644	Delrin Bushing Outer Shell - Upper Control Arm -	8
70012646	Delrin Bushing - Upper Control Arm	8
90002630	Upper Bushing Inner Sleeve	4
70012625	Strut Rod Delrin Ball	4
70012626	Strut Rod Delrin Ball Cap	4
90002656	Strut Rod Delrin Ball Inner Sleeve	2
90002657	Strut Rod Bushing End Spacer	4
23139599	3.85" Stroke Stud Top Shock - Front	2
90002104	Lower Stud Plate - (Installed on Shock) - Front	2
90002654	Upper Shock Mount - Front	2
70011140	Stud Top Bushing - Front	4
70011141	Stud Top Bushing Washer - Front	4
22959599	5.25" Stroke Eyelet Top Shock - Rear	2
70011138	3/4" ID Shock Bushing (Installed in Shock) - Rear	4
90002103	5/8" ID Shock Sleeve (Installed in Shock Eyelet)	2
90002102	1/2" ID Shock Sleeve (Installed in Shock Eyelet)	2
90001617	Shock Stud	2
12099120	Front SwayBar Kit	1
90002496	Leaf Spring Shackle Plates	4
70012605	Frame Shackle Bushing	4
90000519	Leaf Spring Bushing Inner Sleeve	2
90002616	Rear Upper Shock Mount - Driver	1
90002614	Rear Upper Shock Mount - Passenger	1
90002617	Upper Shock Mount Clamp Plate - Driver	1
90002615	Upper Shock Mount Clamp Plate - Passenger	1



Installation Instructions



Getting Started.....

Congratulations on your purchase of the Ridetech StreetGrip Kit. This system has been designed to give your car excellent ride and handling along with a lifetime of enjoyment. Some of the key features of this Kit: Dual Rate CoilSprings, Composite Leaf Springs, Delrin Control Arm & Leaf Spring Bushings, Larger Swaybar with Delrin Liners and a Ridetech HQ Series Monotube Shocks.

The majority of the StreetGrip Components will be installed together. For example, the Front CoilSprings, Control Arm Bushings and Shocks will be installed in conjunction with each other. On the rear, the Leaf Springs, Delrin Bushings and Shocks will be installed in conjunction with each other. The front SwayBar will need to be installed after the rest of the front components are installed.

Front Suspension

The front components that will need to be installed are: Control Arm Bushings, Shocks, and CoilSprings. The SwayBar needs to be installed after the rest of the front components are installed.

If you have never done this type of work before, we recommend getting a Factory Service Manual for proper procedures of disassembly and reassembly of the components for your car.

Rear Suspension

The rear components that will be installed are rear Composite Leaf Springs, Delrin Leaf Spring Bushings, and rear HQ Series Shocks. The Composite Leaf Springs and Delrin Leaf Spring Bushings will be installed at the same time. The Delrin Leaf Spring Bushings are preinstalled in the Leaf Springs.



Part # 12099590 - 1964-1966 Mustang Delrin Control Arm Bushings



Recommended Tools



1964-1966 Mustang Delrin Control Arm Bushings

Installation Instructions

Table of contents

Page 2..... Included components and Hardware List

Page 3&4..... Bushing Installation



Major ComponentsIn the box

Part #	Description	QTY	
90002655	Upper Control Arm Cross Shaft	2	
70012644	Upper Control Arm Bushing Outer Shell	4	
90002630	Upper Bushing Inner Sleeve	4	
70012646	Upper Delrin Control Arm Bushing	4	
70012625	Strut Rod Bushing, Inner Delrin Ball	4	
70012626	Strut Rod Bushing, Outer Cap	4	
90002656	Strut Rod Bushing, Inner Sleeve	2	
90002657	Strut Rod Bushing, End Spacer	4	
70012675	Drilling Template	1	
90002627	4 Bolt Ball Joint Wedge	2	
90002628	3 bolt Ball Joint Wedge	2	
90002629	Ball Joint Wedge Washers	8	
99562007	9/16"-18 Mechanical Lock Nut	Upper Control Arm Shaft Nuts	4
99563002	9/16" SAE Flat Washer	Upper Control Arm Shaft Washers	4
99501043	1/2"-13 x 2" Hex Bolt	Upper Cross Shaft Mounting	4
99503001	1/2" SAE Flat Washer	Upper Cross Shaft Mounting	4
99502015	1/2"-13 Mechanical Lock Nut	Upper Cross Shaft Mounting	4
99562007	9/16"-18 Jam Nut	Strut Rod Nut	2
99311028	5/16"-18 X 1 1/2" Hex Bolt	Ball Joint Wedge	8
99313002	5/16" SAE Flat Washer	Ball Joint Wedge	8
99312002	5/16"-18 Nylok Nut	Ball Joint Wedge	8

Getting Started.....

The Front Control Arms will need to be removed from the car. If it has any shims, mark them, they will be reinstalled in the same location they were removed from. Detach the Strut Rod from the Control Arm. Retain the OEM hardware for reassembly. Refer to the Factory Service Manual for disassembly procedure.

This Mustang Bushing Kit contains: 2 Upper Cross Shafts, 4 Upper Control Arm Bushing Assemblies and 2 Strut Rod Bushing Assemblies. The Upper Bushings are all the same. The Kit does not include a Lower Control Arm Bushing.

The OEM Bushings are removed by threading them out of the Control Arm. It is easier to do with the cross shaft clamped in a vise.



Delrin Bushing Installation

The Cross Shaft must be put in place before installing the Bushing Shells in the Upper & Lower Control Arms.

There are several ways the Delrin Bushing Assemblies can be installed. No matter the method used, the Control Arm needs to be **SUPPORTED** to keep from distorting the Control Arm. We recommend cutting spacers to go inside the Control Arms when using a Press to install the Bushings. We have used several different methods to install the Bushing Assemblies. We are going to cover the one that worked best for us. When installing the Bushings, the Outer Shell will be installed in the Arm by itself. Next, Press in the Delrin Bushing, followed by the Inner Sleeve.

DUE TO VARIATIONS IN THE THREADS OF THE CONTROL ARM, WE RECOMMEND TACK WELDING THE BUSHING SHELLS TO THE CONTROL ARM.

Note: The Delrin is self-lubricating, no lubricant is needed.

1. Measure the **Outside Width** of the Control Arms and write it down before starting Bushing Removal. You will use this dimension to check the Control Arms after the new Delrin Bushings are installed.



2. **Disassemble the Bushing being installed. When installing Bushings in the control arms, insert the Cross Shaft before installing any Bushings. Support the back side of the flange the Bushing is being Installed in.** They can be supported by either the piece of Metal or by the Bench Vise with the Jaws opened wide enough to let the Bushing Shell pass through (**Figure 2**).

3. We used a socket to drive the Outer Shell into the control arm. Drive it in until the Shell stops against the control arm.

4. Press the Delrin Bushing & Inner Sleeve into the Bushing Shell. Again, we used a socket large enough to clear the threads of the cross shaft. Tap them in until the Bushing stops against the Shell and the Inner Sleeve stops against the cross shaft.

5. Install the 9/16" Washer & 9/16" Lock Nut and finish pushing the Bushings in with the hardware. Tighten Hardware to eliminate any gaps between the Bushings and cross shaft. (**Figure 3**) Shows the Control Arm Bushings assembled with the hardware installed.

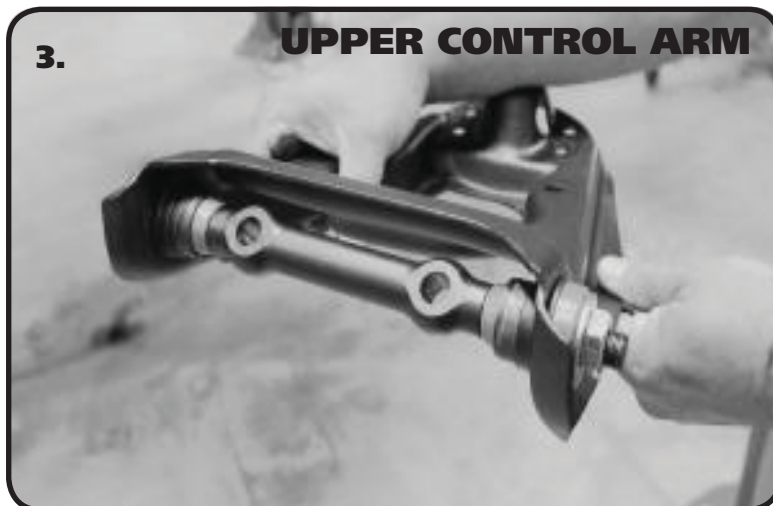



Bushing Installation

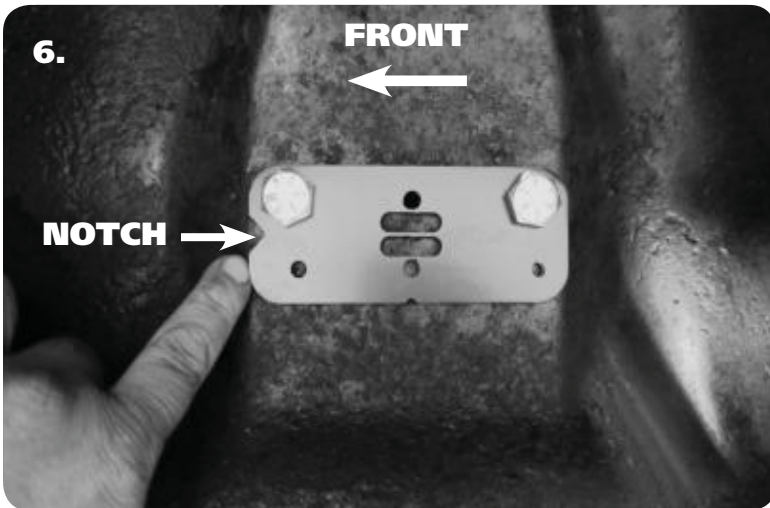

6. This Kit includes a Template for redrilling the upper control arm mounting holes. Use the 1/2" Hex Bolts supplied in the kit to help locate the Template. Insert the 1/2" Bolts into the 2 holes in the Template. Next, install the Template in the control arm location with the **NOTCH FORWARD** and the 1/2" Bolts to the top. Use the 2 small holes to mark the holes that need drilled. Center punch the marks and drill to 1/2". Reinstall the upper control arms in the new holes using the 1/2"-13 x 2" Hex Bolts supplied in the kit. Reinstall any shims that were removed during disassembly. Install a 1/2" Flat Washer and 1/2" Mechanical Locking Nut on the engine side of the control arm mount.

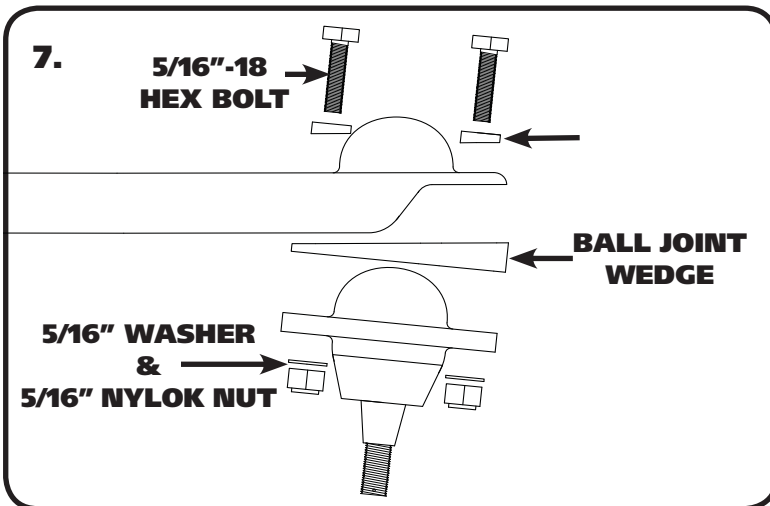

7. The Kit contains Ball Joint Wedges to correct the ball joint angles due to the upper control arm pivot point being lowered. Your control arms will either have 3 or 4 bolts attaching the ball joint to the control arm, this kit contains wedges for both. First, remove the upper balljoint by either unbolting or removing the rivets. The rivets can be removed by either cutting the heads off and driving out or by drilling them out. Use **(Figure 7)** as a reference to install the wedges. The wedge gets install between the upper control arm and the ball joint with the **THICK SIDE OUT**. The wedge shaped washers go on the top side of the arm. Install a Wedged Washer on each of the 5/16"-18 x 1 1/2" bolts required to attach the Wedge/Ball Joint. Insert the into the holes in the control arm. Slide the Wedge on the Bolts with the **THICK SIDE OUT**. Next, install the ball joint followed by a 5/16" Flat Washer and 5/16"-18 Nylok Nut on each bolt. Tighten Hardware.



8. A Delrin Bushing setup for the strut rod is also included in this kit. The liner that is installed in the frame hole has to be removed. Use a chisel to distort it and remove it. In **(Figure 10)** we distorted it from the bottom edge and removed it.



Strut Rod Delrin Bushing Installation



9. Refer to **(Figure 10)** for the Delrin Strut Rod Bushing assembly order. The Delrin Strut Rod Bushing will insert into the frame bushing hole with the rounded side of the bushing outward. A Bushing needs to be installed on both the front and rear side of the frame. With a Delrin Strut Rod Bushing on each side of the frame, insert the INNER Sleeve in the Bushings. This will help hold them in place.

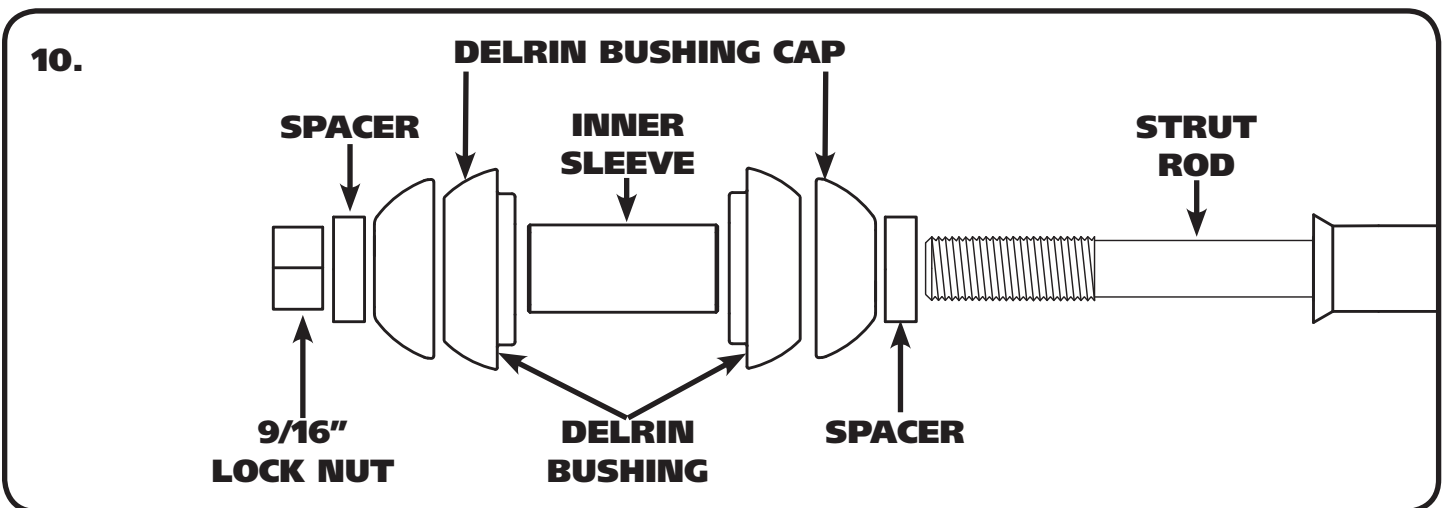

10. Install a Spacer on the strut rod followed by the Delrin Bushing Cap. Insert the strut rod through the Bushing Sleeve until the Ball is nested into the Bushing Cap. Install a second Bushing Cap on the strut rod followed by a 2nd Spacer. Next, install a 9/16" Lock Nut on the threads of the strut rod. Install the OEM castle nut on the end of the strut rod with a cotter pin through it.

NOTE: The Spacers that are on each side of the Delrin Ball Caps can be used to help get the alignment set. Meaning they can both be on the front side of the Delrin Ball Assembly or on the back side of the Assembly. This can help with Caster Adjustment.

11. Reinstall the lower control arm using the OEM eccentric bolt. Reattach the strut rod to the lower control arm using the OEM hardware.

12. Reinstall the spindles using the OEM Hardware.



Part # 12092350 1964-1966 Mustang Front CoilSpring



Recommended Tools

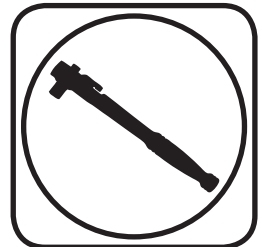

1964-1966 Mustang Front CoilSprings Installation Instructions

CoilSpring # 55490792 Installation

Front dual-rate spring will allow the vehicle to transition small road irregularities via a soft spring rate. When the vehicle compresses the spring far enough (through large bumps or cornering), it transitions to the firmer spring rate to control the bump or body roll. We have worked closely with Hyperco to develop custom dual rates to ensure the best ride possible.

The Front Control Arm Bushings and Strut Rod Bushings should be installed before installing spring. The Front Suspension should be assembled without the Shock installed.

1. CLOSE COILS TO THE BOTTOM.

2. With the OEM Spring Removed, insert the CoilSpring into the Pocket. SPECIAL ATTENTION NEEDS TO BE PLACED ON THE LOCATION OF THE ENDS OF THE SPRINGS TO MAKE SURE THEY ARE CLOKED CORRECTLY . The end of the CoilSpring will nest into the receiver area of the Spring Mount. If you line up the bottom, the top will be correct.

3. Pull down on the Control Arms and install the CoilSpring. Install the Shock to help hold the springs in place.





Part # 12099120 - 1964-1966 Mustang Front SwayBar



Recommended Tools



1964-1966 Mustang Front SwayBar Installation Instructions

Table of contents	
Page 11.....	Included components and Hardware List
Page 12.....	SwayBar Installation
Page 13.....	SwayBar Installation

Install all Front StreetGrip Components before installing the SwayBar.



Major ComponentsIn the box

Part #	Description	QTY
90002638	Front SwayBar	1
90002570	End Link Kit	1
70012402	Delrin Sway Bar Bushing Liner	2
90002572	Bushing Strap	2
90002539	SwayBar Bushing	2

Part #	Description	Usage	QTY
99371003	3/8" -16 x 1" Hex Bolt	Bushing Strap to Frame Mount	4
99373003	3/8" Flat Washer	Bushing Strap to Frame Mount	4
99372002	3/8" -16 Nylok Nut	Bushing Strap to Frame Mount	4

Getting Started.....

Install all Front StreetGrip Components before installing the SwayBar.

Remove the OEM Swaybar to prepare for the StreetGrip SwayBar installation.

This SwayBar kit utilizes a Delrin Liner in the SwayBar Bushing. The Delrin Liner allows the Swaybar to move freely and quietly in the Bushing. The Delrin is self-lubricating, no lubrication is required.



1. The Delrin Liner is split on one side to ease installation. We found it easier to install by opening up the Liner enough to slide it onto the end of the SwayBar, then sliding it into position. It will open up and slide over the curves in the Bar. Install a Liner on each side of the SwayBar in the approximate location they will need to be when installing the SwayBar on the Car.

Note: The Delrin is self-lubricating, no lubricant is needed.



SwayBar Installation



2. Open up the Poly SwayBar Bushings and install them over the Delrin Sleeves.

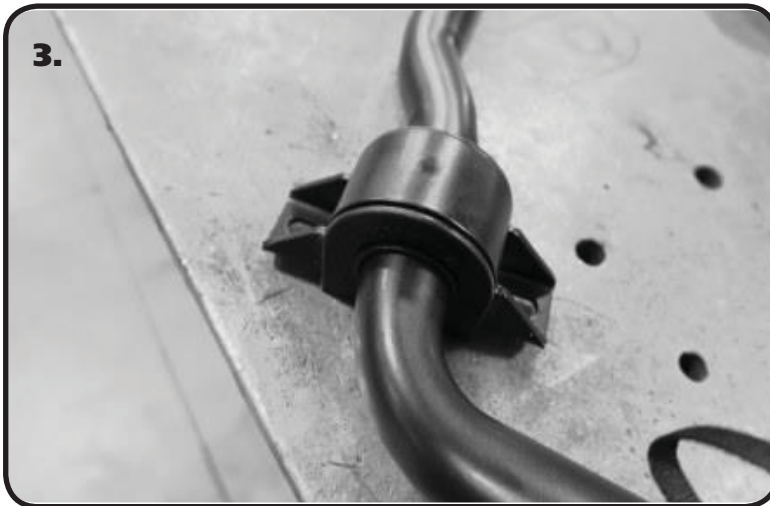

3. Install Bushing Straps Over the Poly Sway-Bar Bushings.

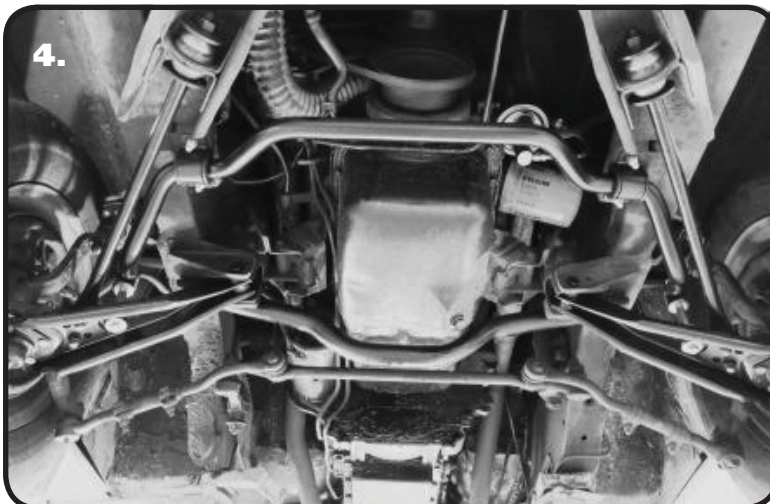

4. Slide the SwayBar into position on the Car. The SwayBar Arms will be above the Control Arms. Install a 3/8" Flat Washer on (4) 3/8"-16 x 1" Hex Bolts. A Bolt/Washer will go in each of the 4 mounting holes. With the Bolt/Washers installed, install a 3/8" Flat Washer on the threads followed by a 3/8"-16 Nylok Nut. Do **NOT** Completely tighten the Hardware. It will be left partially loose until the End Links are installed.



SwayBar Installation

5.

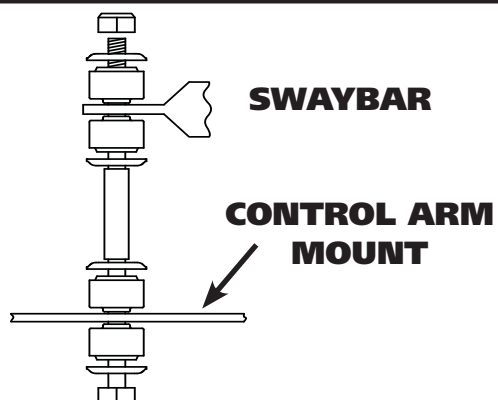

5. Install the End Links. Use **(Figure 5)** for proper installation. Tighten the Hex Nut enough to slightly compress the Bushings.

6. Tighten the Sway Bar Mounting Hardware.

Part # 12099515 - 1964-1966 Mustang Front Shock Kit

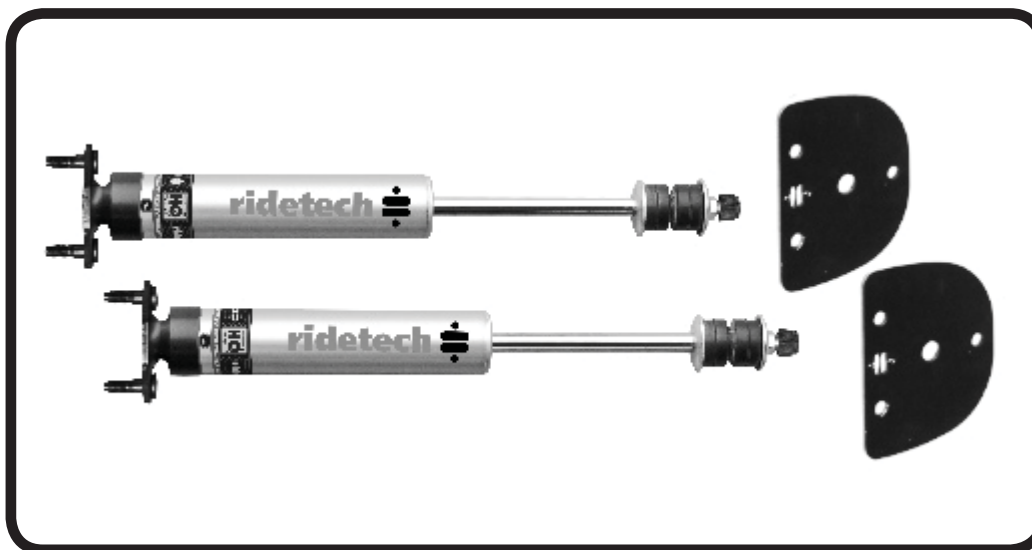

Recommended Tools

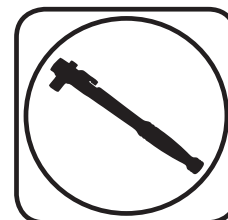
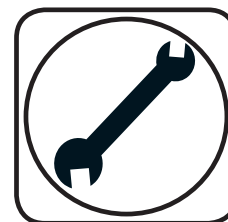

HQ Series Front Shock Kit Installation Instructions

Table of contents

Page 14..... Components & Shock Installation

Page 15-16.... Shock Installation & Adjustment



3.85" HQ Series Smooth Body Shocks

Major ComponentsIn the box

Part #	Description	QTY
23139999	3.85" Stroke Shock	2
90002104	Stud Plate (Installed on Shock)	2
99371009	3/8"-24 x 5/8" FHCS (Installed on Shock)	2
99311020	5/16"-24 x 1 1/4" BHCS (Installed on Shock)	2
72000229	Stud Plate Bushings	2
70011140	Stud Top Bushings	4
70011141	Stud Top Bushing Washers	4
90002654	Upper Shock Mounting Plate	2

HARDWARE

Part #	Description	Usage	QTY
99372006	3/8"-24 Jam Nut	Upper Shock Bushings	4
99312001	5/16"-24 Nylok Nut	Lower Shock Mount	4
99313002	5/16" Flat Washer	Lower Shock Mount & Upper Plate	10
99311027	5/16"-18 x 3/4" Carriage Bolt	Upper Shock Mount Plate	6
99312003	5/16"-18 Nylok Nut	Upper Shock Mount Plate	6

Getting Started.....

FOR OPTIMUM PERFORMANCE, THIS KIT SHOULD BE USED IN CONJUNCTION WITH THE STREET-GRIP COIL SPRINGS, DELRIN BUSHINGS, AND SWAY BAR.

1. Remove the OEM shock setup along with the OEM upper shock mount. If the car is equipped with a shock tower brace, it will need to be moved out of the way to install the new Upper Mount. It can be reinstalled while installing the new Upper Mount.

REPLACE THE CONTROL ARM BUSHINGS AND COIL SPRINGS BEFORE INSTALLING THE NEW SHOCK KIT.



Shock Installation

2.

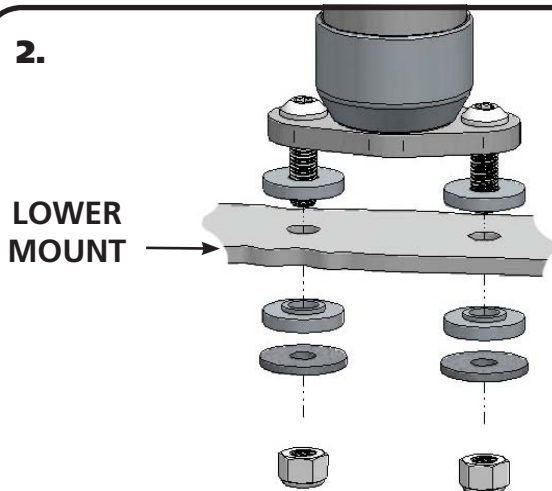

2. **(Figure 2)** shows the assembly of the lower shock bushings. Install a Bushing on the each of threads protruding through the lower shock plates.

3.



3. Using **(Figure 5)**, install a Stud Top Bushing Washer and Bushing on the Stud Top of the Shock. Insert the Shock through the OEM opening. Insert the studs into the openings in the lower mount. Using **(Figure 2)** as a reference, install a Bushing, Washer and Nut on each stud and tighten.

4.

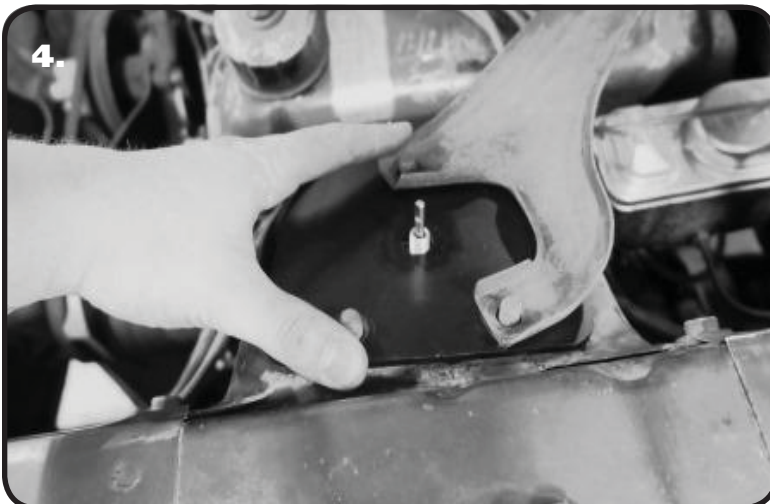

4. Insert the supplied 3/8"-16 x 1" Carriage Bolts in the OEM keyhole slots in the top of the shock tower. Install the Upper Shock Plate on the Carriage Bolts with the Stud Top of the Shock inserted into the center hole. The Inner Hole on the Shock Plate is offset if the holes are not lining up, FLIP IT OVER. If the car has a strut tower brace, install in on top of the plate. Once everything is in place, install a 3/8" Flat Washer & 3/8"-16 Nylok Nut on the threads sticking up. Tighten the hardware.



Shock Installation

5.

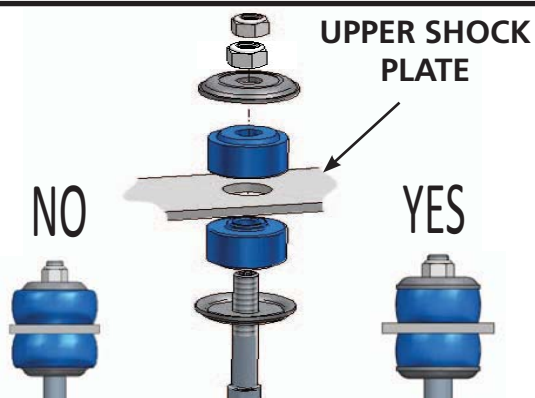

5. Install a Stud Top Bushing & Bushing Washer on the Shock. Install a 3/8"-24 Jam nut on the threads and tighten until the Bushings just start to bulge. Install a 2nd 3/8"-24 Jam Nut and tighten it against the 1st.

Part # 12094799 - 1964-1966 Mustang Composite Leaf Springs

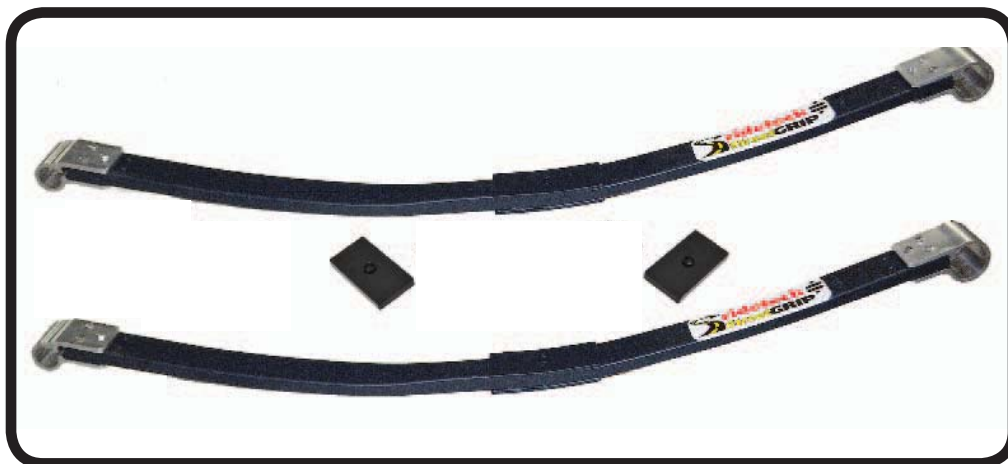

Recommended Tools

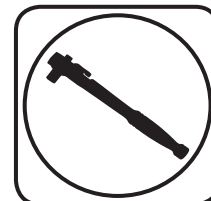
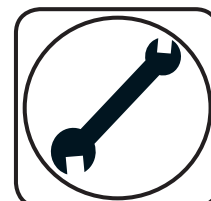

64-66 Mustang Composite Leaf Springs & Delrin Bushings Installation Instructions

Table of contents

- Page 17..... Included components and Hardware List
- Page 18..... Delrin Frame Bushing Installation
- Page 19..... Leaf Spring Installation

IT IS VERY IMPORTANT THAT NOTHING COMES IN CONTACT WITH THE COMPOSITE LEAF SPRINGS.



Major ComponentsIn the box

Part #	Description	QTY
70012826	Leaf Spring Blade (Blade Assembly)	2
70012408/ 70012353	Leaf Spring Eyelet (Blade Assembly) Front/Rear	2
99251015	1/4"-20 x 1 3/4" Flange Bolt (Blade Assembly)	12
99252004	1/2"-20 Flange Nut (Blade Assembly)	12

12095399 Delrin Bushing Kit

Part #	Description	QTY
70012652	Delrin Front Leaf Spring Bushing (Installed in Leaf Spring)	
70012653	Delrin Rear Leaf Spring Bushing (Installed in Leaf Spring)	
70012605	Delrin Rear Shackle Frame Bushing - 1/4" Flange	4
90000519	Inner Bushing Sleeve - (4) Installed in Springs	6
90002626	1 1/2" Lowering Block w/70012898 pressed in	2
90002496	Shackle Plate	4
99501029	1/2"-13 x 6 1/2" Hex Bolt GR8 - FRONT	2
99501037	1/2"-13 x 4" Hex Bolt GR8 - REAR	4
99502009	1/2"-13 Nylok Nut GR8	6
99436001	7/16"-20 x 6" U-bolt	4
99432002/99433002	7/16"-20 Nylok Nuts/ 7/16" Flat Washers	8

Getting Started.....

IT IS VERY IMPORTANT THAT NOTHING COMES IN CONTACT WITH THE LEAF SPRING.

1. Jack the car up and support it by the frame rails. You will need to raise and lower the rear differential with a jack to ease installation. With the car supported by the frame, put the jack underneath the rear end housing and raise the jack up just enough to support the differential. Remove the rear leaf springs & OEM shocks.
2. The Delrin Bushings will be preinstalled in the Composite Leaf Springs. The Delrin Frame Bushings will need to be installed. Start by removing the OEM frame bushings.
3. The Shackle Plates and Hardware can be used to push the rear bushings into the frame location. Start the bushings into the frame and insert a 1/2"-13 bolt into a shackle plate. Insert the bolt/shackle plate into the bushing and install a second shackle plate on the bolt sticking through the bushing. Install a 1/2"-13 nut and tighten until the bushings bottom out on the frame. Remove the shackle plates and install the inner sleeve.



Leaf Spring Installation

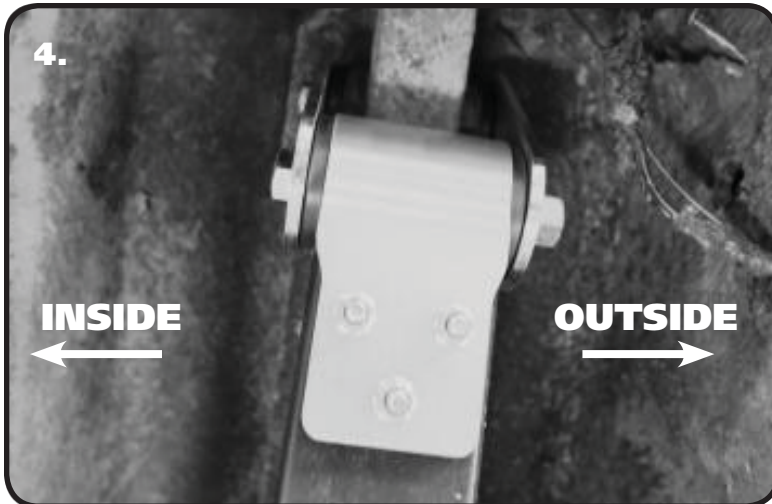

4. Attach the rear of the Composite Leaf Spring to the rear mount. THE REAR BUSHING IS THE **SMALLER** OF THE 2. New Shackles and Hardware is supplied with Delrin Bushings. Attach a Shackle Plate to each side of the Frame Bushing using a 1/2"-13 x 4" Bolt (WITH THREADS POINTING TO OUTSIDE OF CAR) and 1/2"-13 Nylok Nut. Do not tighten. Align the remaining bolt holes in the shackle plates with the sleeve in the rear Leaf Spring bushing. Install a 1/2"-13 x 4" Bolt (WITH THREADS POINTING TO OUTSIDE OF CAR) and 1/2"-13 Nylok Nut. Do Not tighten hardware, it will get tightened later.



5. Swing the Leaf Spring up and attach the **LARGE BUSHING END** of the Composite Leaf Spring into the OEM front leaf spring mount using a 1/2"-13 x 4.5" Hex Bolt and 1/2"-13 Nylok Nut.

Note: You may have to jack the rear differential up enough to swing the leaf spring in place.

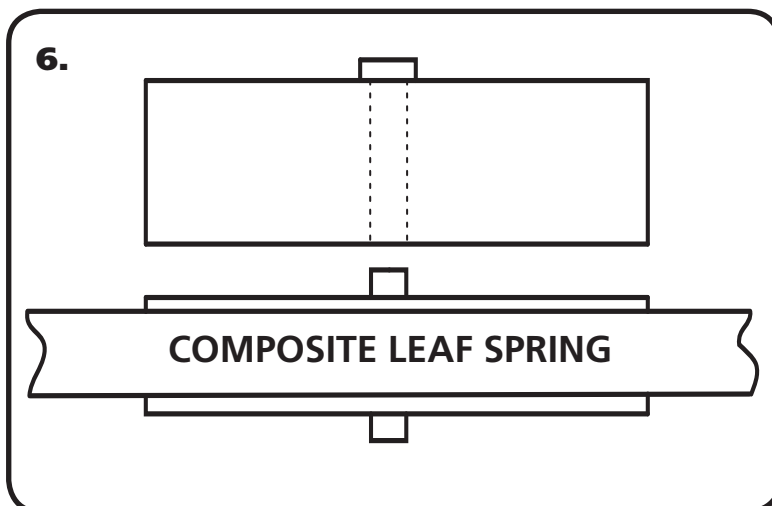

6. This Kit use a Lowering Block to help get the proper design height. Install the 1 1/2" Lowering Block on top of the leaf spring with the locating pin inserted into the center hole of the block. Lower the differential with the Lowering Block in place like shown in **(Figure 6)**. The PIN on the Lowering Block needs to be inserted into the HOLE in the OEM leaf spring mount.



Leaf Spring Installation

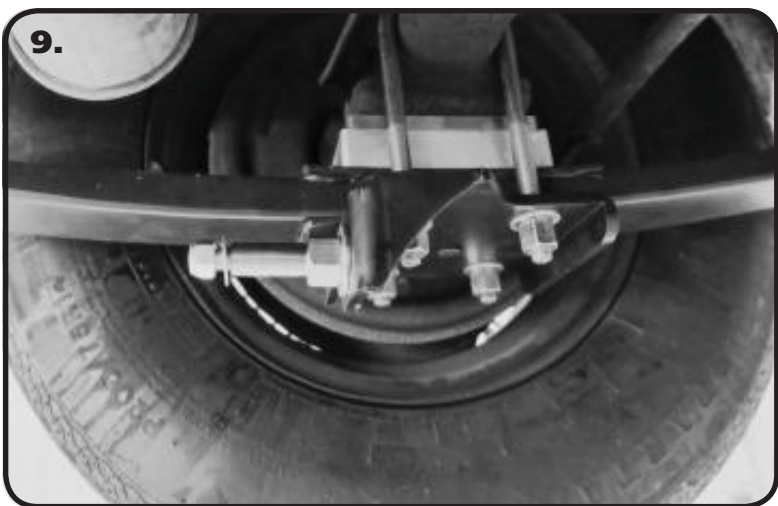
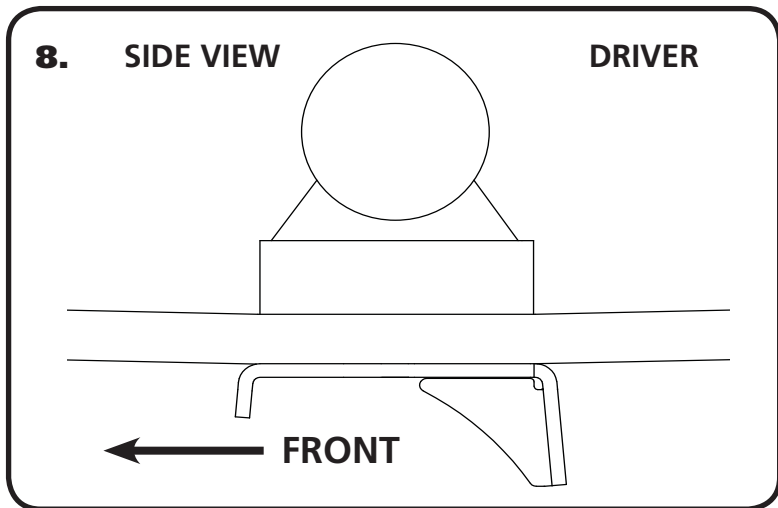
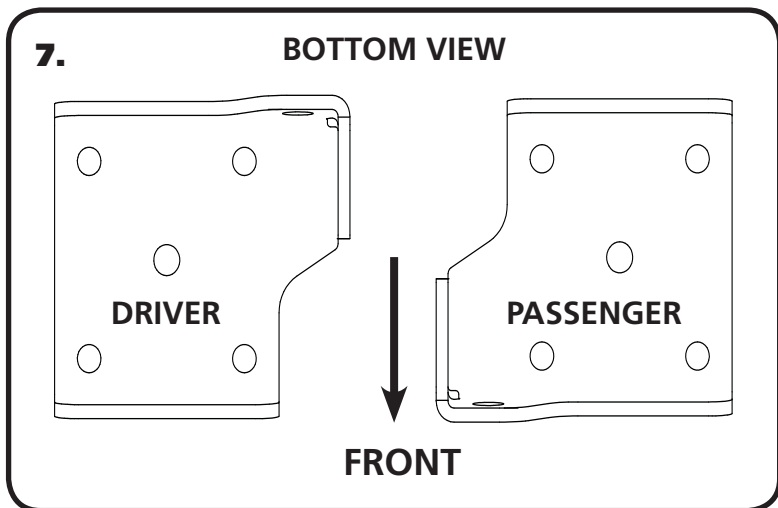

7. Install the lower U-Bolt Plate/Shock Mount being sure the Pins and Holes are aligned. (Figure 7) shows the U-bolt Plates/Shock Mounts as viewed from the bottom. (Figure 8) shows the Driver Mount viewed from the outside of the car. The Driver Mount positions the bottom of the shock to the inside behind the axle. The Passenger Mount positions the bottom of the shock to the inside in front of the axle, IT HAS A "P" STAMPED IN IT. Install the 7/16" U-bolts on the axle tube in place of the OEM u-bolts. Slide the New U-bolt Plates onto the U-bolts using (Figure 8) as a reference. Verify that the lower locating pin is indexed into the locating hole of the Plate. Install the hardware on each U-bolt. Evenly tighten the hardware by tightening in a crisscross fashion. Torque the nuts to 55 ftlbs. (Figure 9) shows the Driver Plate installed.

Composite Leaf Spring Note: When tightening the mounts, pay attention to the pads on the springs to make sure there is visible compression of the pads. .030"-.060" of compression is needed for the springs to be securely mounted. All of the clamping force needs to be on the spring itself.

10. Tighten the Bushing hardware, torquing it to 75 ftlbs. The Delrin Bushings will not bind, so it isn't necessary to have the car at ride height.

11. **DOUBLE CHECK TO MAKE SURE NOTHING IS COMING INTO CONTACT WITH THE LEAF SPRING.**



Part # 12099510 - 64-66 Mustang Staggered Shock Kit



Recommended Tools

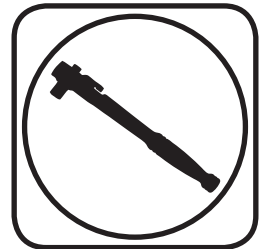

HQ Series Staggered Shock Kit Installation Instructions

Table of contents

- Page 21..... Components
- Page 22..... Upper Mount Installation
- Page 23..... Shock Installation
- Page 24..... Shock Adjustment

THE LOWER MOUNT SHOULD BE INSTALLED ALONG WITH THE COMPOSITE LEAF SPRINGS.





5.25" HQ Series Smooth Body Shocks

Major ComponentsIn the box

Part #	Description	QTY
22959999	5.25" Stroke Shock	2
70011138	3/4" ID Shock Bushing (Installed in Shock)	4
90002103	5/8" ID Shock Sleeve (Installed in Shock Eyelet)	2
90002102	1/2" ID Shock Sleeve (Installed in Shock Body)	2
90002616	Upper Shock Mount Assembly - Driver	1
90002614	Upper Shock Mount Assembly - Passenger	1
90002617	Upper Shock Mount Inner Brace - Driver	1
90002615	Upper Shock Mount Inner Brace - Passenger	1
90001617	Lower Shock Stud	2
90000471	Cantilever Pin Spacer	2
90002556	Leaf Spring U-bolt Plate - Driver	1
90002610	Leaf Spring U-bolt Plate - Passenger "P" Stamped on Part	1

HARDWARE

Part #	Description	Usage	QTY
99431002	7/16"-14 x 1 1/4" Hex Bolt	Passenger Upper Shock Mount to Body	1
99433002	7/16" Flat Washer	Passenger Upper Shock Mount to Body	2
99432001	7/16"-14 Nylok Nut	Passenger Upper Shock Mount to Body	1
99311011	5/16"-18 x 1 1/4" Hex Bolt	Driver Upper Shock Mount to Body	7
99312002	5/16"-18 Nylok Nut	Driver Upper Shock Mount to Body	7
99313002	5/16" Flat Washer	Driver Upper Shock Mount to Body	14
99501010	1/2"-20 x 2 1/4" Hex Bolt	Shock to Upper Shock Mount	2
99503001	1/2" Flat Washer	Shock to Upper Shock Mount	4
99502002	1/2"-20 Nylok Nut	Shock to Upper Shock Mount	2

The Rear Shocks will be installed in conjunction with the Rear Leaf Springs.



Upper Mount Installation

THE LOWER PLATES ARE INSTALLED ALONG WITH THE COMPOSITE LEAF SPRINGS.

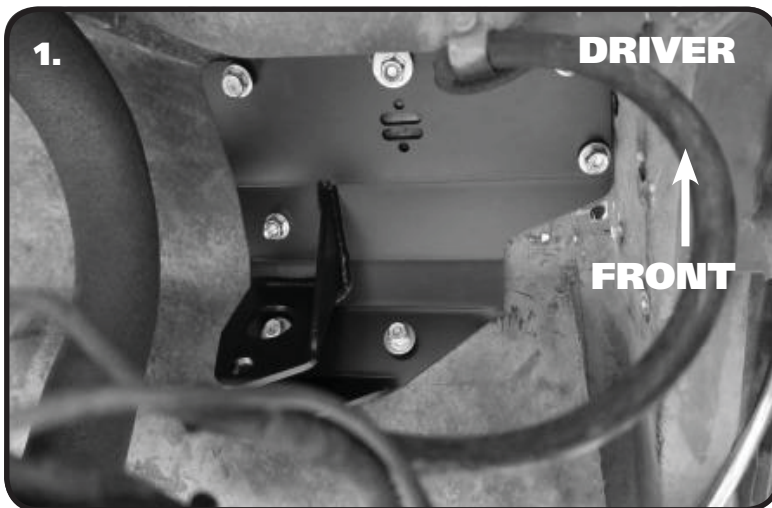

1. The Driver Upper Shock Mount repositions the top of the shock behind the axle. The Mount nests in the car one way. Position the Mount in the car with the Shock attaching point to the rear and away from the frame. The outside edge of the mount will touch the frame with the front edge against a body seam. Using these points as a guide, the Mount will fit the contours of the body. With the Mount in position, use it to mark the 7 holes and drill them 5/16"

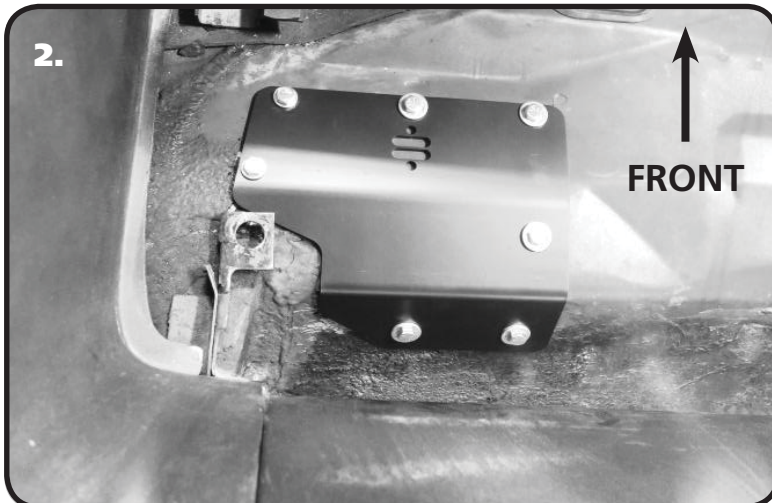

2. After drilling the 5/16" holes for the Driver Mount, position the backer plate on the inside of the car. Use **(Figure 6)** as a reference. When the Backer is put into place, it will fit the contours of the body, aligning with the drilled holes. Install a Flat Washer on each of the 5/16"-18 x 1 1/4" Hex Bolts and insert them through the Backer and Body. Hold the Shock Mount in place and install a 5/16" Flat Washer and 5/16"-18 Nylok on each of the Bolts sticking through the Backer and Body. Tighten the hardware.



3. Install the Passenger Shock Mount in the OEM location. The Shock Mount will only fit into the OEM location one way. Install a 7/16" Flat Washer on a 7/16"-14 x 1 1/4" Hex Bolt and insert it into the hole in the mount. THE THREADS MUST POINT UP. Install the Backer on the inside of the car in the OEM location, lining up the holes. With the Bolt sticking through, install a 7/16" Flat Washer and 7/16"-14 Nylok Nut on the threads sticking through. Tighten the hardware making sure the Mount stays in position.



Shock Installation



4. The Shock is mounted in the Upper Mount with the BODY UP. It is held in place with a 1/2"-20 x 2 1/4" Hex Bolt & 1/2"-20 Nylok with a 1/2" Flat Washer on each side of the bracket.

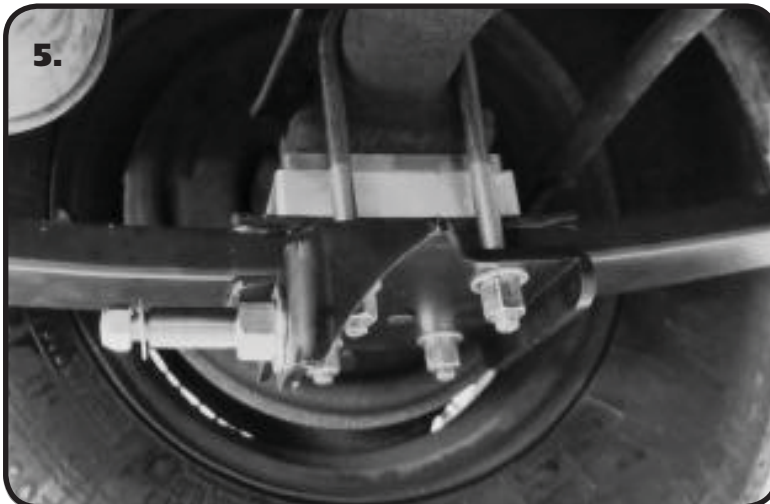

5. The Lower Shock is Bolted to the Lower Shock Mount using the supplied Shock Stud. Install the Studs into the Lower Mounts with a Washer on each side of the Mount. Slide a Washer onto the Stud. Jack the Rear Differential up until the Shocks can be slid onto the Shock Stud. Slide the Shock onto the Stud with the Adjuster Knob pointing inward. Install the supplied 7/16" Flat Washer and Nylok Nut onto the Threads and tighten.



Shock Adjustment

Shock adjustment 101- Single Adjustable

Rebound Adjustment:

How to adjust your new shocks

The rebound adjustment knob is located on the top of the shock absorber protruding from the eyelet or stud top. You must first begin at the ZERO rebound setting, then set the shock to a street setting of 12 or handling setting of 8.



-Begin with the shocks adjusted to the ZERO rebound position (full stiff). Do this by rotating the rebound adjuster knob clockwise until it stops.

-Now turn the rebound adjuster knob counter clockwise 12 clicks. This sets the shock at 12 for a street setting. If you are after a handling setting only go 8 clicks.

Take the vehicle for a test drive.



-if you are satisfied with the ride quality, do not do anything, you are set!

-if the vehicle is too soft increase the damping effect by rotating the rebound knob clockwise 3 additional clicks.

-If the vehicle is too stiff rotate the rebound adjustment knob counter clock wise 2 clicks and you are set!

Take the vehicle for another test drive and repeat the above steps until the ride quality is satisfactory.

Note:

One end of the vehicle will likely reach the desired setting before the other end. If this happens stop adjusting the satisfied end and keep adjusting the unsatisfied end until the overall ride quality is satisfactory.